

FTDI Chip

VM800C Datasheet

Embedded Video Engine

Credit Card Board



General Purpose Multi Media Controller

1 Introduction

The VM800C is a development module for FTDI's FT800, which is used to develop and demonstrate the functionality of the FT800 Embedded Video Engine, EVE. This module behaves as an SPI slave, and requires a SPI Master for proper micro-controller interfacing and system integration.

VM800C modules support 3 different LCD panel size options. Users can also connect to different LCD screens as long as they meet the FT800 technical specification and fit the VM800C LCD connector.

- VM800C35A-D, 3.3/5V micro-controller adaptor card with 3.5" LCD touch display
- VM800C43A-D, 3.3/5V micro-controller adaptor card with 4.3" LCD touch display
- VM800C50A-D, 3.3/5V micro-controller adaptor card with 5.0" LCD
- VMFT800C35A-N, 3.3/5V micro-controller adaptor card, with 3.5" LCD connector but no display
- VMFT800C43A-N, 3.3/5V micro-controller adaptor card, with 4.3/5.0" LCD connector but no display

1.1 Features

The VM800C utilises the FTDI FT800 Embedded Video Engine. Graphic, audio and touch features of the FT800 can be accessed with the VM800C. For a full list of the FT800's features please see the FT800 datasheet.

The VM800C has the following features:

- Ready to use LCD module
- Part types with LCDs supporting resistive touch with pressure sensing.
- On board LCD backlight LED Driver
- Supports mono audio output
- On board audio power amplifier and micro speaker
- Flexible power supply. Powering the VM800C using either a 2.1mm power jack , SPI master connector or via USB Micro-B port
- 5 V tolerant buffers when used with a 5V SPI Master.

Neither the whole nor any part of the information contained in, or the product described in this manual, may be adapted or reproduced in any material or electronic form without the prior written consent of the copyright holder. This product and its documentation are supplied on an as-is basis and no warranty as to their suitability for any particular purpose is either made or implied. Future Technology Devices International Ltd will not accept any claim for damages howsoever arising as a result of use or failure of this product. Your statutory rights are not affected. This product or any variant of it is not intended for use in any medical appliance, device or system in which the failure of the product might reasonably be expected to result in personal injury. This document provides preliminary information that may be subject to change without notice. No freedom to use patents or other intellectual property rights is implied by the publication of this document. Future Technology Devices International Ltd, Unit 1, 2 Seaward Place, Centurion Business Park, Glasgow G41 1HH United Kingdom. Scotland Registered Company Number: SC136640

2 Ordering Information

Note that the kits below require a 5V/1A power supply. It is NOT provided in the development kit, but is offered as an optional accessory, as is the USB to SPI cable, with the following part types:

Part No.	Description
VM800C35A-N	Credit Card Size VM800C module, supports 3.3/5v MCU Adapter Board, with FPC/FFC 54 LCD connector. No display is provided.
VM800C43A-N	Credit Card Size VM800C module, supports 3.3/5v MCU Adapter Board, with FPC/FFC 40 LCD. No display is provided.
VM800C35A-D	Credit Card Size VM800C module, supports 3.3/5v MCU Adapter Board, with FPC/FFC 54 LCD connector, 3.5 inch TFT LCD display panel preinstalled.
VM800C43A-D	Credit Card Size VM800C module, supports 3.3/5v MCU Adapter Board, with FPC/FFC 40 LCD connector, 4.3 inch TFT LCD display panel preinstalled.
VM800C50A-D	Credit Card Size VM800C module, supports 3.3/5v MCU Adapter Board, with FPC/FFC 40 LCD connector, 5.0 inch TFT LCD display panel preinstalled.
VA-PSU-UK1	Accessory - UK Model 5V/1A USB Power Supply (Mfr # JX-B0520C-1-B)
VA-PSU-US1	Accessory - US Model 5V/1A USB Power Supply (Mfr # JX-B0520B-1-B)
VA-PSU-EU1	Accessory - EU Model 5V/1A USB Power Supply (Mfr # JX-B0520A-1-B)
VA800A-SPI	Accessory - High Speed Micro USB to SPI adapter for BASIC boards based on FT232H MPSSE design
VA-FC-1M-BKW	Accessory - Flat USB A to Micro B Cable 1M- Black and White
VA-FC-1M-BLW	Accessory - Flat USB A to Micro B Cable 1M- Blue and White
VA-FC-STYLUS1	Accessory - Resistive Touch Screen Pen Stylus

Table 2-1 – Ordering information

Table of Contents

1	Introduction	1
1.1	Features.....	1
2	Ordering Information	2
3	Hardware Description	4
3.1	VM800C board.....	4
3.2	Physical Descriptions	5
3.2.1	PCB layout.....	5
3.2.2	VM800C Connectors.....	6
4	Board Schematics.....	10
5	Hardware Setup Guide	14
5.1	Power Configuration	14
5.2	MPSSE Setup.....	14
5.3	Arduino® Setup	16
6	Mechanical Dimensions	17
6.1	VM800C35A - 3.5" Dimensions.....	17
6.2	VM800C43A - 4.3" Dimensions.....	19
6.3	VM800C50A - 5.0" Dimensions.....	21
7	Specifications.....	23
7.1	Optical Specification	23
8	Contact Information.....	25
Appendix A - References		20
Document References		20
Appendix B - List of Figures and Tables		21
List of Figures		21
List of Tables		21
Appendix C – Revision History		22

3 Hardware Description

Please refer to section **3.2.2** for connector settings. Some VM800C jumpers must be set to work properly with your system.

3.1 VM800C board

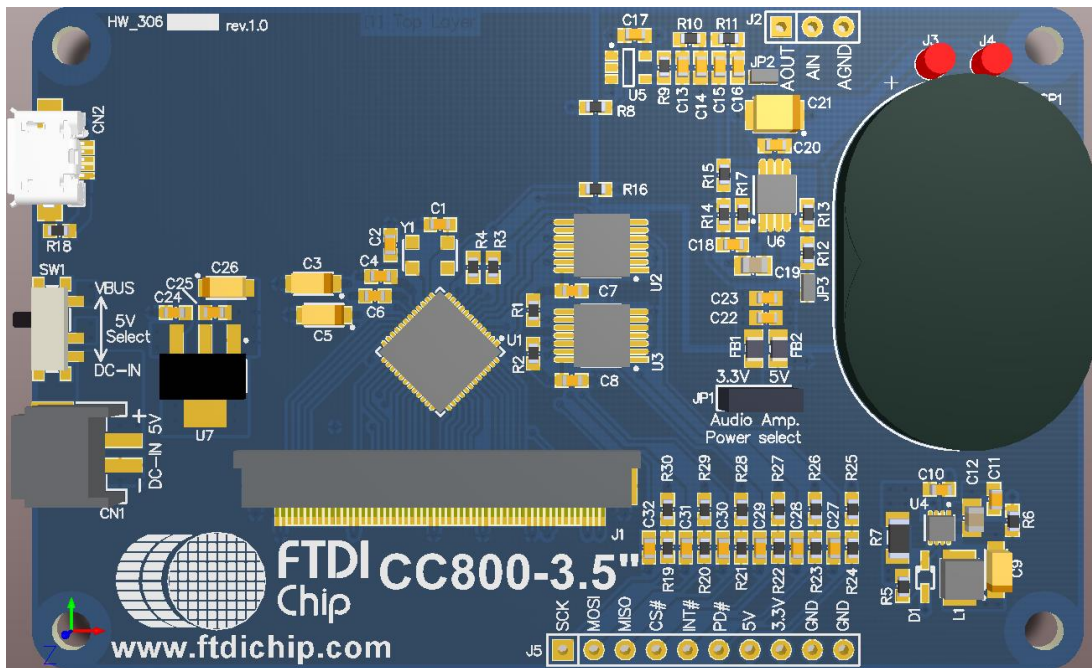

Figure 3-1 – VM800C board profile 3.5" display version

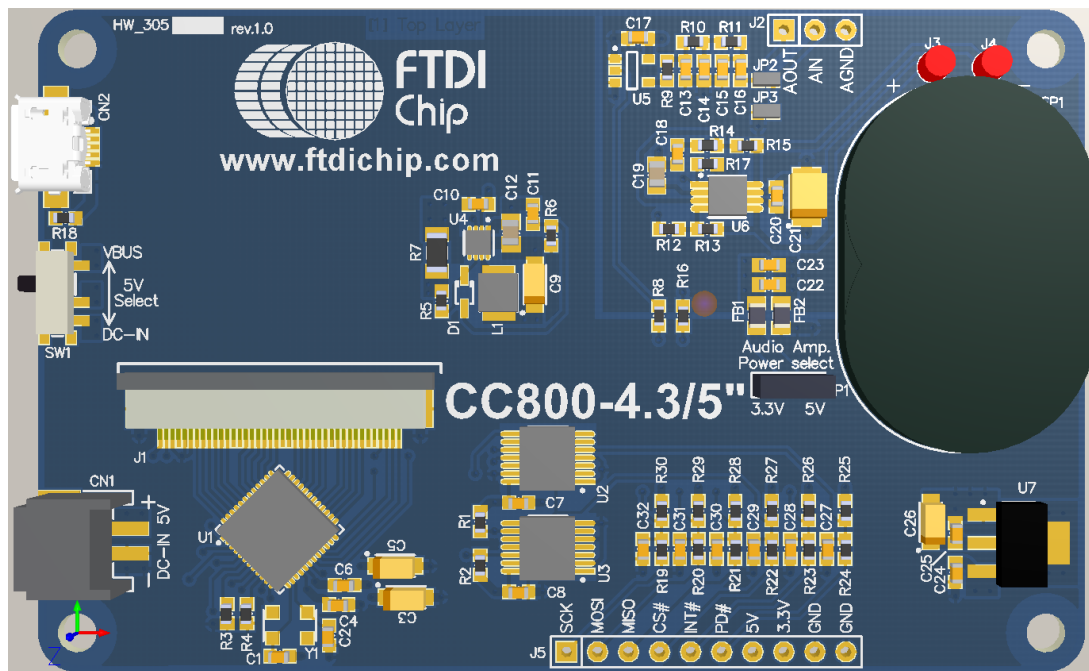

Figure 3-2 - VM800C board profile 4.3"/5" display version

The VM800C module is intended for direct use into existing applications that require a display. This module is suitable for interfacing with an external microcontroller that has a SPI Master channel.

The VM800C module PCB comes in 2 types, 3.5 inch as well as a 4.3/5 inch model. The difference between the 2 models is the flex cable receptacle of the LCD. The 3.5 inch LCD uses a 54 pin receptacle, whereas the 4.3/5 inch model uses a 40 pin receptacle.

The main functions of the VM800C are as follows:

- Micro USB, SPI connector or 2-pin connector for power supply
- 3.3V regulator : Takes 5V input and outputs 3.3V for on-board circuits
- LCD touch screen panel
- LCD backlight driver. On board back light driver has over voltage protection (OVP).

Part No	OVP (v)	Backlight drive current (mA)
VM800C35A-N	34	20
VM800C43A-N	34	32
VM800C35A-D	24	20
VM800C43A-D	24	32
VM800C50A-D	24	32

Table 3-1 LED backlight drive OVP and current

- 5V tolerant buffers between the SPI master interface and the Slave interface of the FT800
 - SPI timing requirement can be referred to FT800 datasheet. The on board level convert buffers introduce additional delay. The actual maximum SPI clock frequency depends on the host system timing and connection cable length to VM800C.
- 3 stage audio filter and power amplifier
- 8Ω speaker
- Audio line out option

3.2 Physical Descriptions

3.2.1 PCB layout

The VM800C module is 85.6 x 54.1mm, four-layer printed circuit board. Board thickness is approximately 1.6mm.

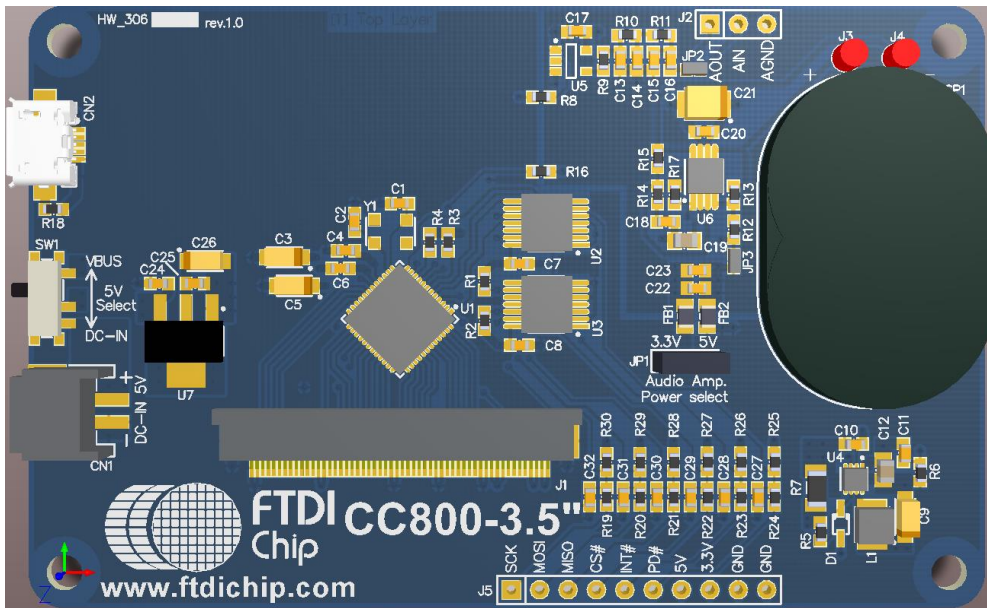

Figure 3-3 - VM800C module top view, 3.5 inch display version

3.2.2 VM800C Connectors

Connectors and jumpers are described in the following sections.

- **CN1- 2-pin power connector**

2 pin connector for 5V/3.3V power input to the board. Alternative to Micro USB connector.

Pin No.	Name	Type	Description
1	VCC	P	5V or 3.3V DC power supply
2	GND	P	Ground

Table 3-2 – CN1 Pinout

- **CN2- Micro USB Receptacle**

This receptacle is strictly for 5V input to power the board. There is no USB Functionality

Pin No.	Name	Type	Description
1	VBUS	P	5V power supply
2	NC	NA	No connection
3	NC	NA	No connection
4	NC	NA	No connection
5	GND	P	Ground

Table 3-3 – CN2 Pinout

- **J1- LCD Flex Cable connector**

This connector is the interface between the FT800 IC and the LCD Module.

Signal	Pin No (3.5")	Pin No (4.3/5.0")	Description
LED K	1,2	1	LED Cathode
LED A	3,4	2	LED Cathode
DISP	8	31	General purpose output pin for LCD Display Enable, push-pull output, 4/8mA sink/source current. Control by writing to Bit 7 of REG_GPIO register.
HSYNC	36	32	LCD Horizontal Sync, push-pull output, 4/8mA sink/source current.
VSYNC	37	33	LCD Vertical Sync, push-pull output, 4/8mA sink/source current.
DCLK	38	30	LCD Pixel Clock, push-pull output, 4/8mA sink/source current.
DE	52	34	LCD Data Enable, push-pull output, 4/8mA sink/source current.
R2	14	7	Bit 2 of Red RGB signals, push-pull output, 4/8mA sink/source current.
R3	15	8	Bit 3 of Red RGB signals, push-pull output, 4/8mA sink/source current.
R4	16	9	Bit 4 of Red RGB signals, push-pull output, 4/8mA sink/source current.
R5	17	10	Bit 5 of Red RGB signals, push-pull output, 4/8mA sink/source current.
R6	18	11	Bit 6 of Red RGB signals, push-pull output, 4/8mA sink/source current.
R7	19	12	Bit 7 of Red RGB signals, push-pull output, 4/8mA sink/source current.
G2	22	15	Bit 2 of Green RGB signals, push-pull output, 4/8mA sink/source current
G3	23	16	Bit 3 of Green RGB signals, push-pull output, 4/8mA sink/source current
G4	24	17	Bit 4 of Green RGB signals, push-pull output, 4/8mA sink/source current
G5	25	18	Bit 5 of Green RGB signals, push-pull output, 4/8mA sink/source current
G6	26	19	Bit 6 of Green RGB signals, push-pull output, 4/8mA sink/source current

Signal	Pin No (3.5")	Pin No (4.3/5.0")	Description
G7	27	20	Bit 7 of Green RGB signals, push-pull output, 4/8mA sink/source current
B2	30	23	Bit 2 of Blue RGB signals, push-pull output, 4/8mA sink/source current.
B3	31	24	Bit 3 of Blue RGB signals, push-pull output, 4/8mA sink/source current.
B4	32	25	Bit 4 of Blue RGB signals, push-pull output, 4/8mA sink/source current.
B5	33	26	Bit 5 of Blue RGB signals, push-pull output, 4/8mA sink/source current.
B6	34	27	Bit 6 of Blue RGB signals, push-pull output, 4/8mA sink/source current.
B7	35	28	Bit 7 of Blue RGB signals, push-pull output, 4/8mA sink/source current.
XP	48	37	X +ve touch
YM	49	38	Y -ve touch
XM	50	39	X -ve touch
YP	51	40	Y +ve touch
3V3	9,10,11,41,42	4	3V3 Power
GND	12,13,20,21,28,29,53,54	3,5,6,13,14,21,22,29,36	Ground
NC	5,6,7,39,40,43,44,45,46,47	35	No connect

Table 3-4 – J1 Pinout

- **J2 - Selection between lineout or loop back into the power amplifier.**

Selection between audio lineout or loop back into the power amplifier. (Footprint only, JP2 next to J2 is connected by default for on board amplifier and on board mini speaker). If J2 is soldered and used for audio output selection, JP2 needs to be removed.

Pin No.	Name
1 -2	Audio amp enabled
2-3	Audio amp mute, Audio lineout on pin 1

Table 3-5 – J2 Pin Options

- **J3 – SP+**

Audio speaker +ve from the on-board amplifier.

- **J4 – SP-**

Audio speaker -ve from the on-board amplifier.

- **J5- SPI Interface**

This is the interface where the SPI control and data signals are routed. There are also power and ground pins on this interface. Note J5 is not soldered on the VM800C board by default.

Pin No.	Name	Type	Description
1	SCLK	I	SPI Clock input
2	MOSI	I	Master Out Slave in
3	MISO	O	Master In Slave out
4	CS#	I	Chip select , active low
5	INT#	OD	Host interrupt open drain output, active low. On board 47kΩ pull-up to 3.3V.
6	PD#	I	Active low power down input.
7	5V	P	5V power supply
8	3.3V	P	3.3V power supply
9	GND	P	Ground
10	GND	P	Ground

Table 3-6 – J5 Pinout

- **JP1- Audio Amplifier Power Select**

This jumper provides the option to select the power supply voltage for the on-board power amplifier.

Pin No.	Name
1-2	3V3 selected
2-3	5V selected

Table 3-7 – JP1 Pin options

*This needs to be configured before audio can be heard

- **JP2 – On board amplifier enable**

Solder connection fitted by default

- **JP3 - On board amplifier mute**

Solder connection not fitted by default

- **SW1 – Power source select**

Pin No.	Name
1-2	Power from CN1
2-3	Power from CN2

Table 3-8 – JP1 Pin options

4 Board Schematics

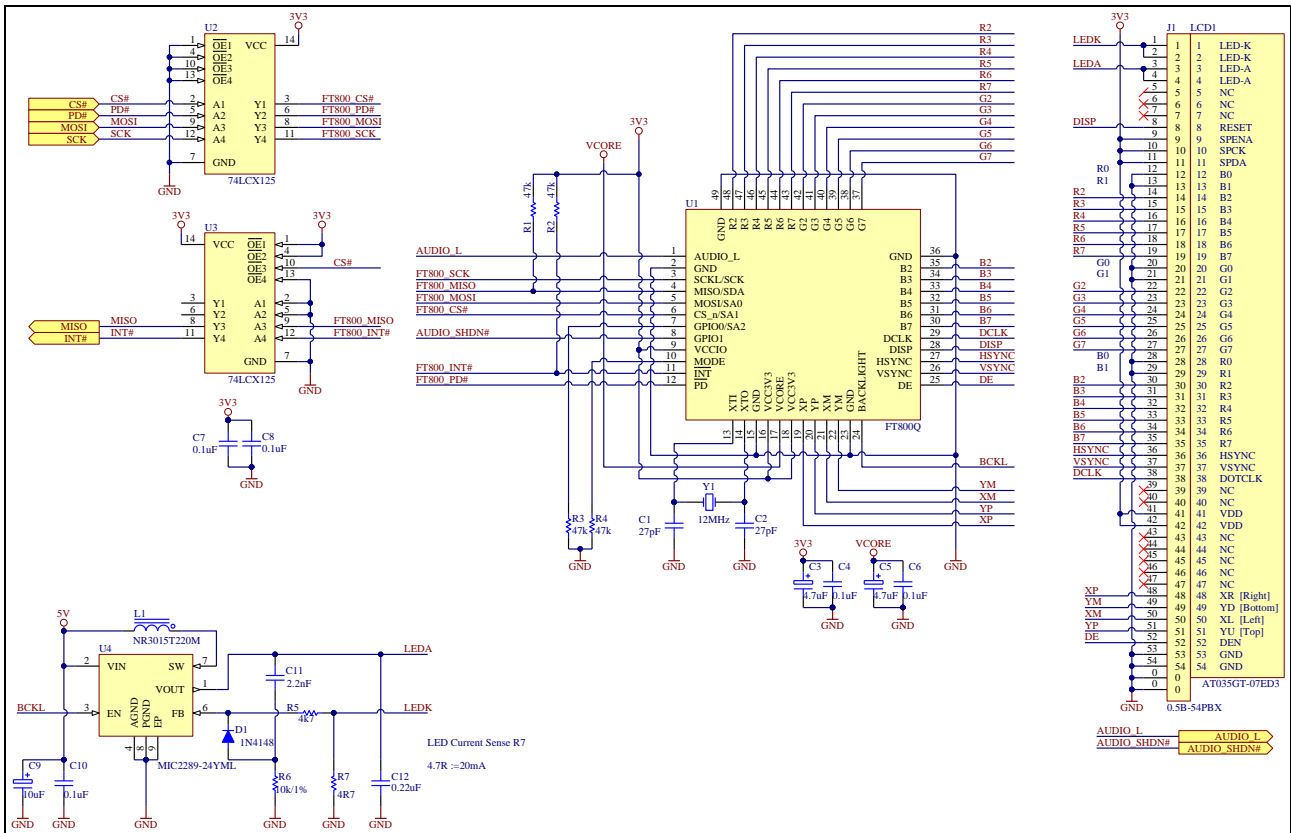

Figure 4-1 - VM800C35 (3.5" Version)

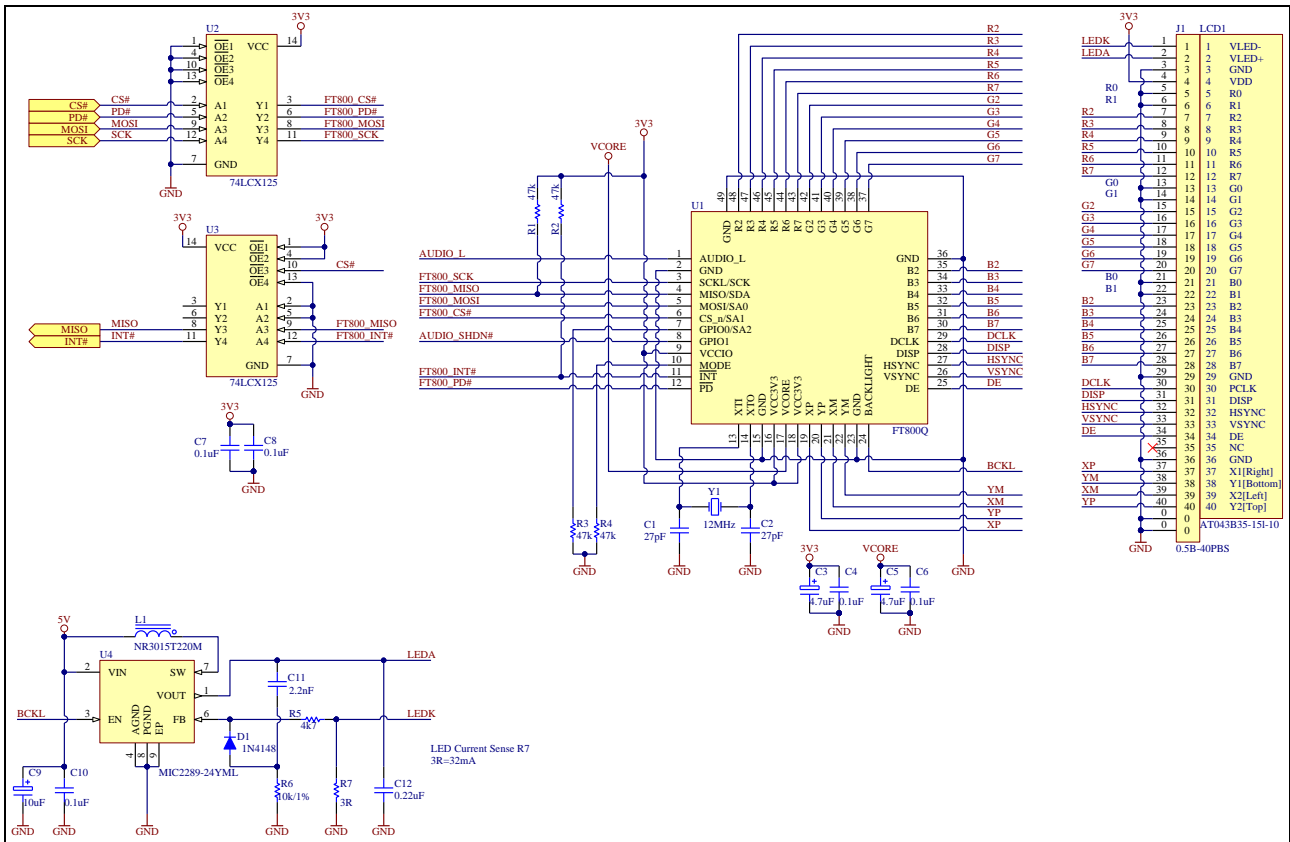

Figure 4-2 - VM800C43/VM800C50 (4.3"/5.0" Version)

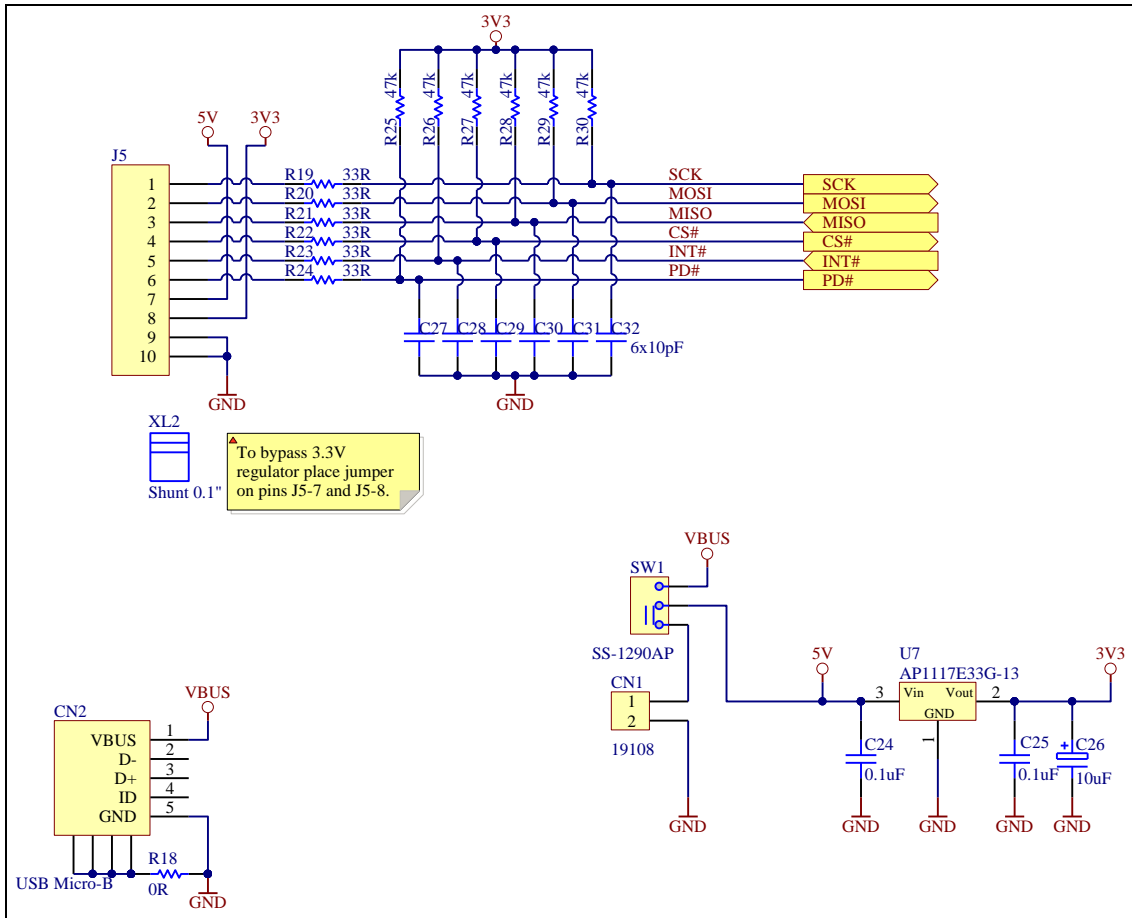

Figure 4-3 – VM800C SPI Interface and IO

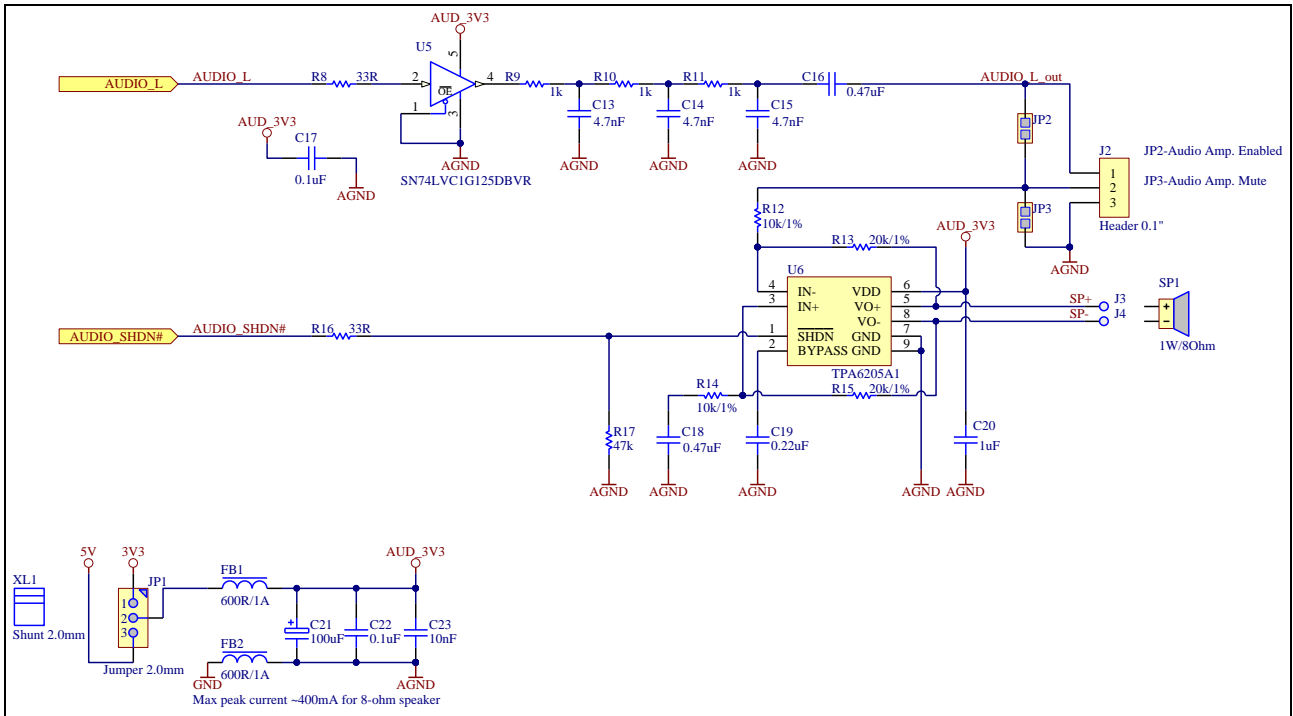

Figure 4-4 – VM800C Audio

5 Hardware Setup Guide

5.1 Power Configuration

There are 5 methods of powering the VM800C board.

- 1) USB Power(5V) - Connect USB power through micro-USB cable to CN2
- 2) DC IN(5V) - Connect 5V to CN1
- 3) DC IN(3.3V) - Connect 3.3V to CN1 and short J5 pin 7 and 8
- 4) J5 Power(5V) - Connect 5V to J5 pin 7
- 5) *J5 Power(3.3V) - Connect 3.3V to J5 pin 7 and 8

*Warning: Applying 5 V accidentally in this mode may cause permanent damage to the VM800C module.

The following table summarise how to power the VM800C board using the various methods.

Power Method	CN2	CN1	J5 Pin 7	J5 Pin 8	SW1
USB Power	5V	N/C	N/C	N/C	Short pin 2-3
DC IN(5V)	N/C	5V	N/C	N/C	Short pin 1-2
DC IN(3.3V)	N/C	3.3V	SHORT		Short pin 1-2
J5 Power(5V)	N/C	N/C	5V	N/C	Any Position
J5 Power (3.3V)	N/C	N/C	3.3V		Any Position

Table 5-1 Board power configuration

5.2 MPSSE Setup

To give a quick start with the VM800C development board, a Windows based Sample Application and demo applications are provided for users to experiment and experience the FT800 in the VM800C system. The following paragraphs provide a short description for development procedures.

MPSSE is a "multi-purpose synchronous serial engine" interface available in some FTDI device (e.g. FT2232D, FT232H, FT2232H and FT4232H). This engine allows users to bridge from a USB port on a PC to an I²C or SPI interface. Sample code is available for driving the FT800 over this interface with a FT232H device that has been integrated into a cable. This device is available in the VA800A-SPI board, or C232HM-EDHSL-0(5V) cable or C232HM-DDHSL-0(3.3V) cable.

VA800A-SPI is a MPSSE module accessory which can connect to the VM800C modules directly. Detailed information of VA800A-SPI can be found at:

<http://www.ftdichip.com/VM800B.htm>.

More information about MPSSE cables may be found at:
http://www.ftdichip.com/Support/Documents/DataSheets/Cables/DS_C232HM_MPSSE_CABLE.pdf.

In this section it is assumed the 5V version of the MPSSE cable (FTDI part no C232HM-EDHSL-0) is used. In case a 3.3V version of the MPSSE cable (FTDI part no C232HM-DDHSL-0) is available, the setup is similar except for the power pin connection. Refer to table 5-1 for board power configuration.

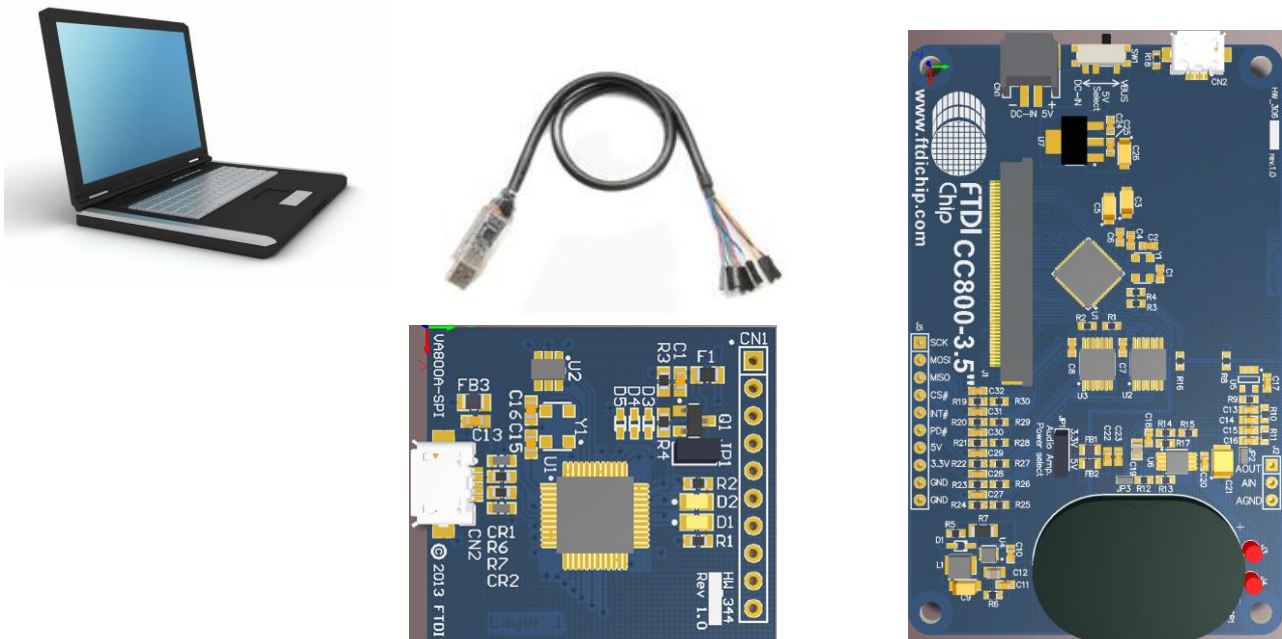

Figure 5-1 – VM800C connects to PC via VA800A-SPI or MPSSE cable

Hardware Setup VA800A-SPI

- Solder a 10 position single row pin header to J5 footprint of the VM800C board
- Connect VA800A-SPI to the VM800C module in the correct orientation.
- Connect USB cable (e.g. FTDI accessory **VA-FC-1M-BKW** or **VA-FC-1M-BLW**) from the VA800A-SPI to the PC USB host port.
- VA800A-SPI will supply power to VM800C after MPSSE driver is properly loaded and the USB host completed USB device configuration.

Hardware Setup MPSSE Cable

- Solder a 10 position single row pin header to J5 footprint of the VM800C board
- Configure JP1 to either 3.3V or 5V
 - Power Audio Amp by 3.3V : JP1 pin1 and pin 2 close
 - Power Audio Amp by 5V : JP1 pin2 and pin 3 close (5V board supply must be provided)
- Connect MPSSE leads to VM800C board's J5(SPI interface) in accordance with Table 5-2
- Plug MPSSE cable to PC USB port

Software Setup

- Download PC Base MPSSE software. MPSSE cable and driver information can be found at <http://www.ftdichip.com/Products/Cables/USBMPSSE.htm>.
- Launch the Sample Application based on MPSSE from PC
- For more information on utilizing the VM800C development system with the MPSSE cable and Sample Application, refer to AN_245.

Further documentation associated with the VM800C development system and design flow can be found at following link: <http://www.ftdichip.com/VM800C.htm>

The FT800 Programming Guide describes the programming code and formats used by the FT800. The Sample Application is a well-formatted and documented program that illustrates the Programming Guide, and provides numerous design examples and reference code demonstrations.

J5 Pin number	J5 Signal	MPSSE pin number	MPSSE Signal	MPSSE Lead Color
1	SCK	2	SK	ORANGE
2	MOSI	3	DO	YELLOW
3	MISO	4	DI	GREEN
4	CS#	5	CS	BROWN
5	INT#	7	GPIOL1	PURPLE
6	PD#	9	GPIOL3	BLUE
7	5V	1	VCC	RED
8	3.3V	-	-	-
9	GND	10	GND	Black
10	GND	-	-	-

Table 5-2 – MPSSE cable (C232HM-EDHSL-0) connection

5.3 Arduino® Setup

Sample codes and demo applications are provided to users who want to connect VM800C to a MCU. FTDI provides sample source code, Sample Application notes (AN_246) and a ready to run demo based on Arduino® platform. Further documentation associated with the VM800C development system and design flow can be found at <http://www.ftdichip.com/VM800C.htm>.

Application note, AN_246, provides a reference guide for utilizing the VM800C development systems with the Sample Application software and Arduino Pro platform.

The FT800 Programming Guide describes the programming code and formats used by the FT800. The Sample Application is a well-formatted and documented program that illustrates the Programming Guide, and provides numerous design examples and reference code demonstrations.

6 Mechanical Dimensions

6.1 VM800C35A - 3.5" Dimensions

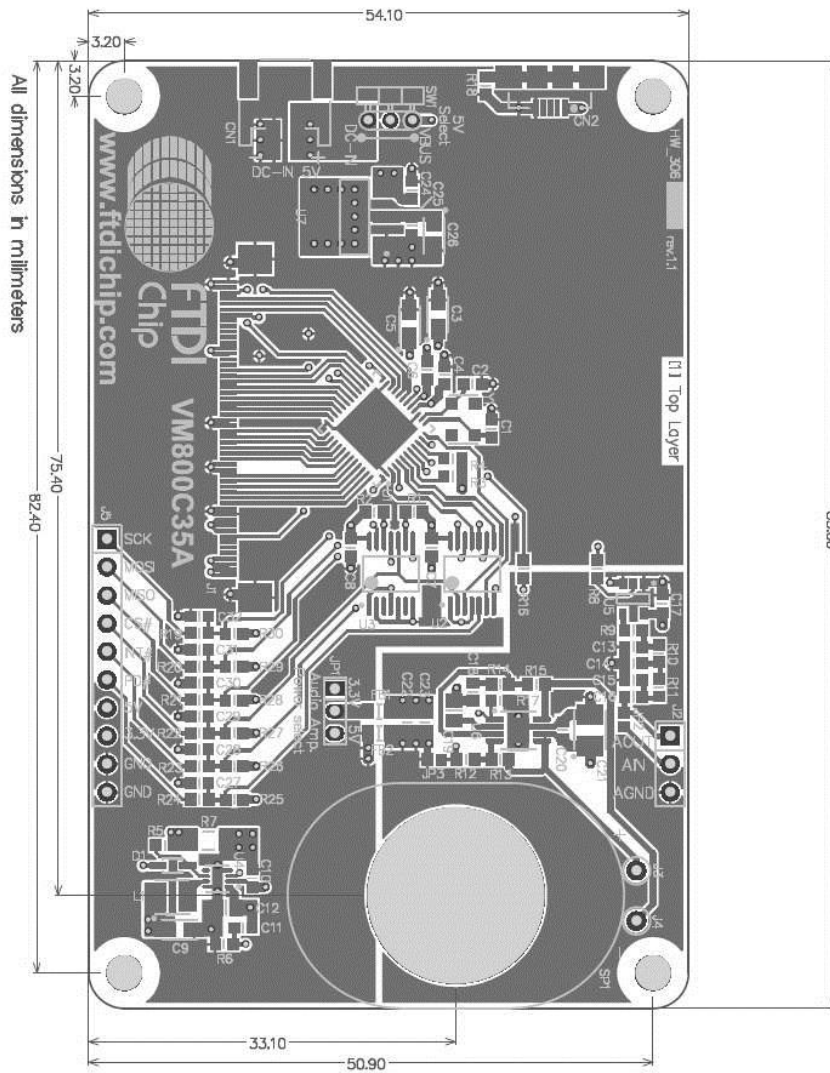

Figure 6-1 – VM800C35A PCB dimensions

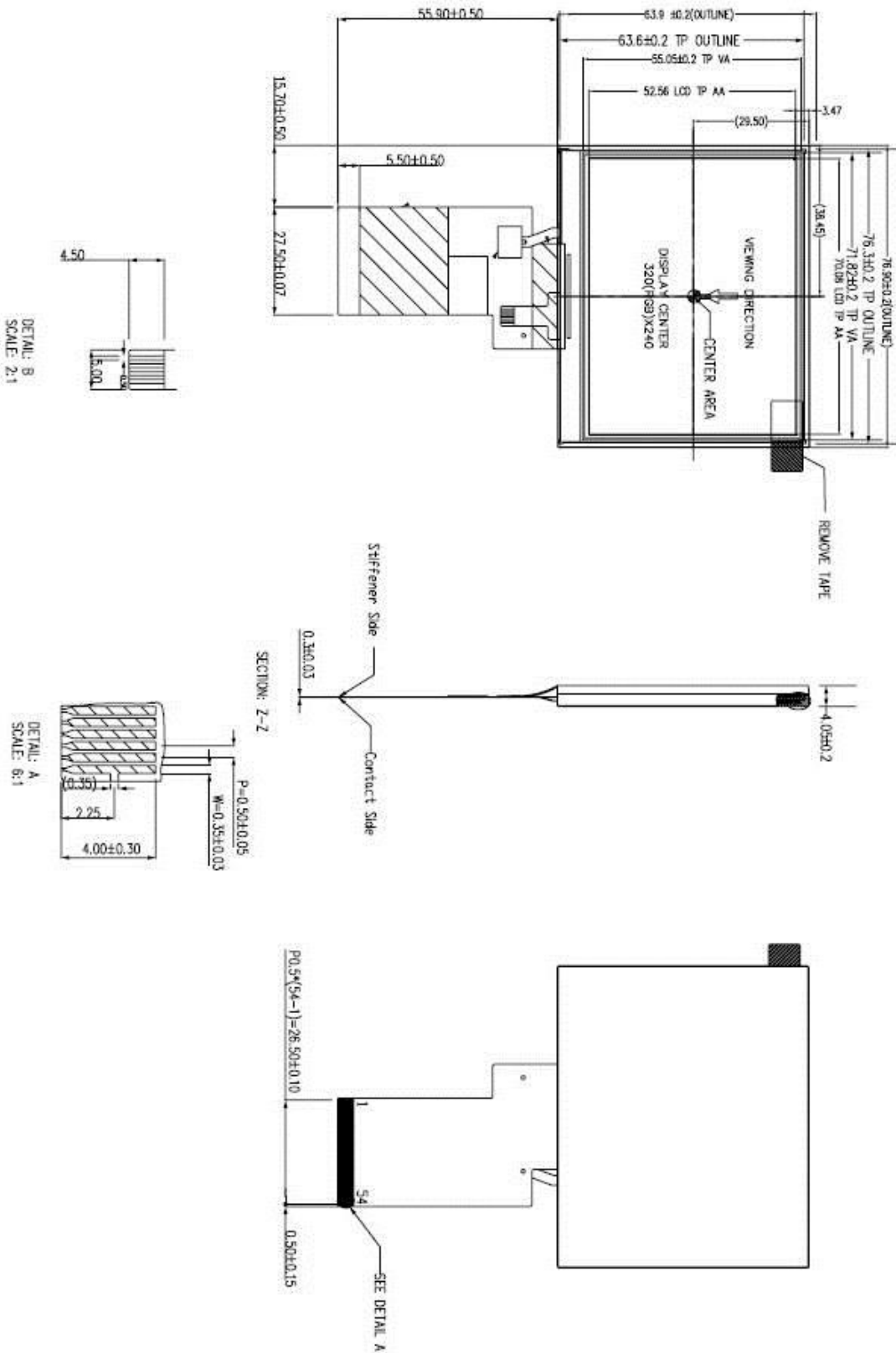

Figure 6-2 – VM800C35A Display dimensions

6.2 VM800C43A - 4.3" Dimensions

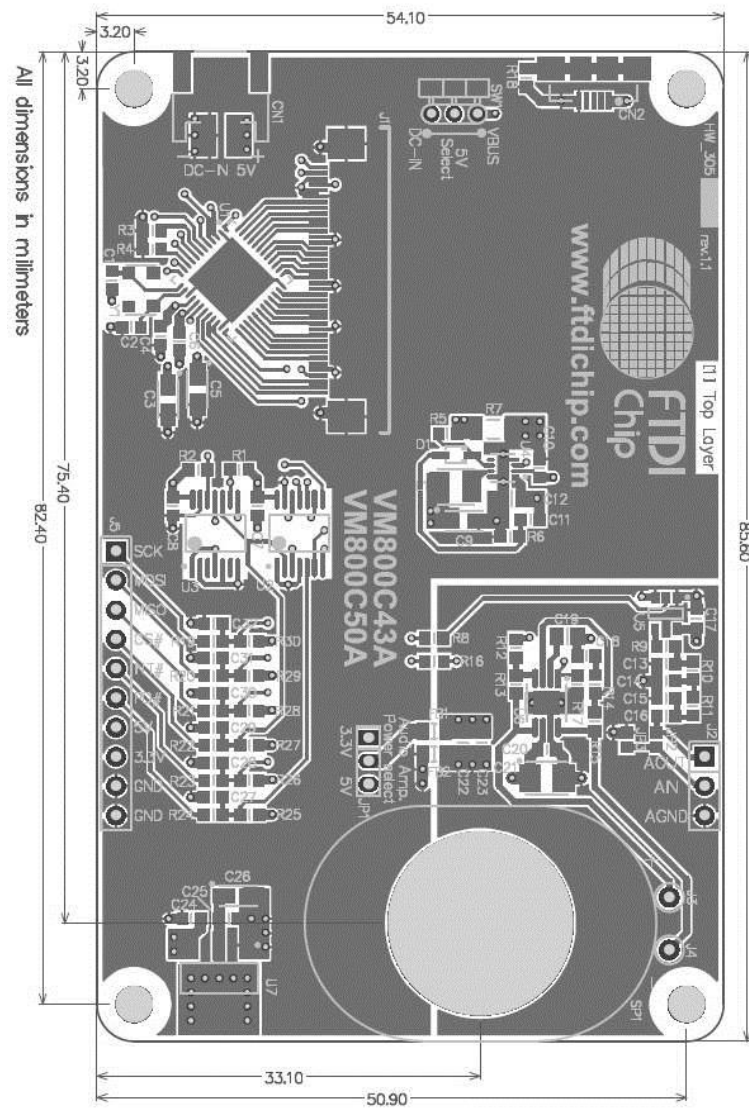

Figure 6-3 – VM800C43A PCB dimensions

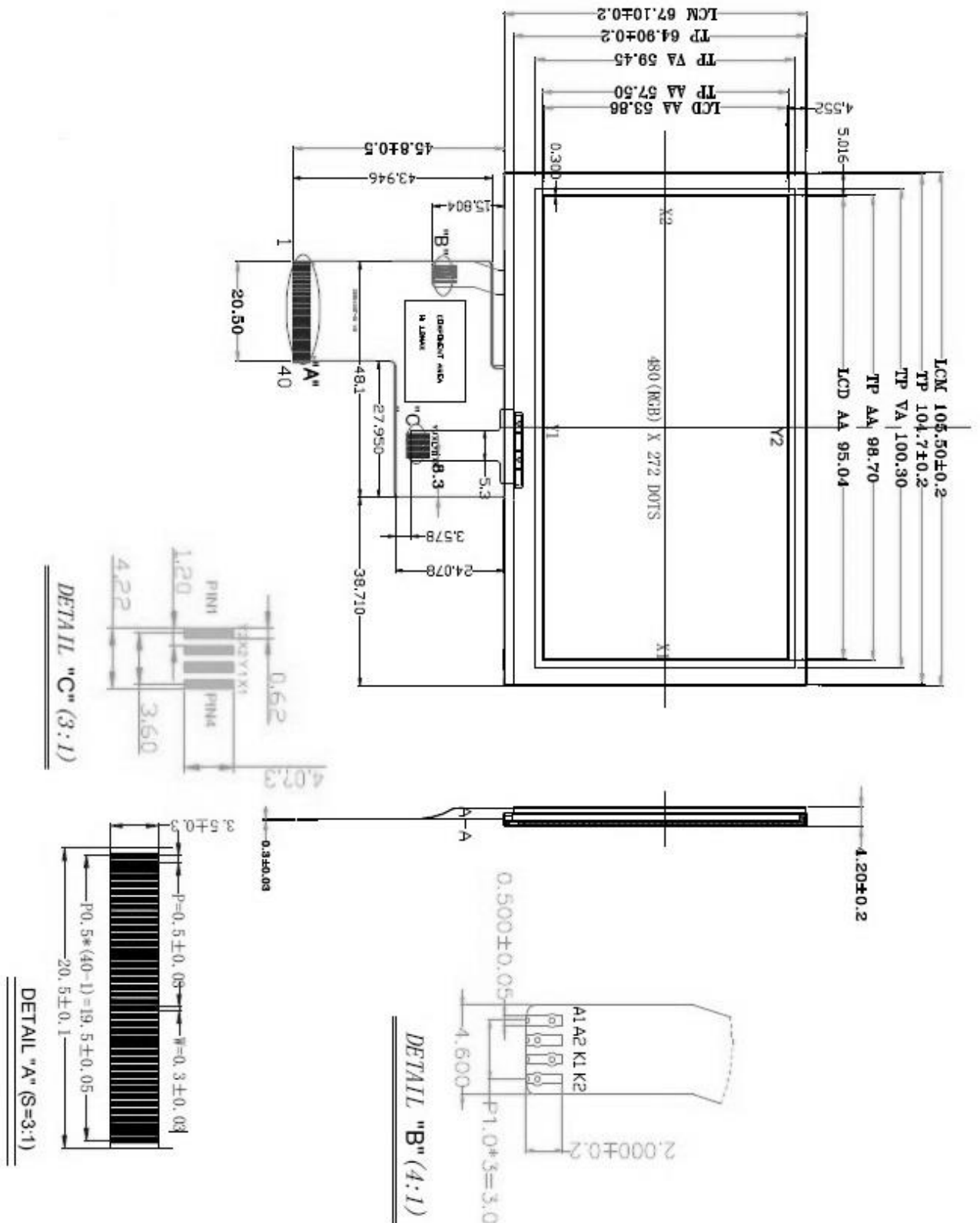

Figure 6-4 - VM800C43A Display dimensions

6.3 VM800C50A - 5.0" Dimensions

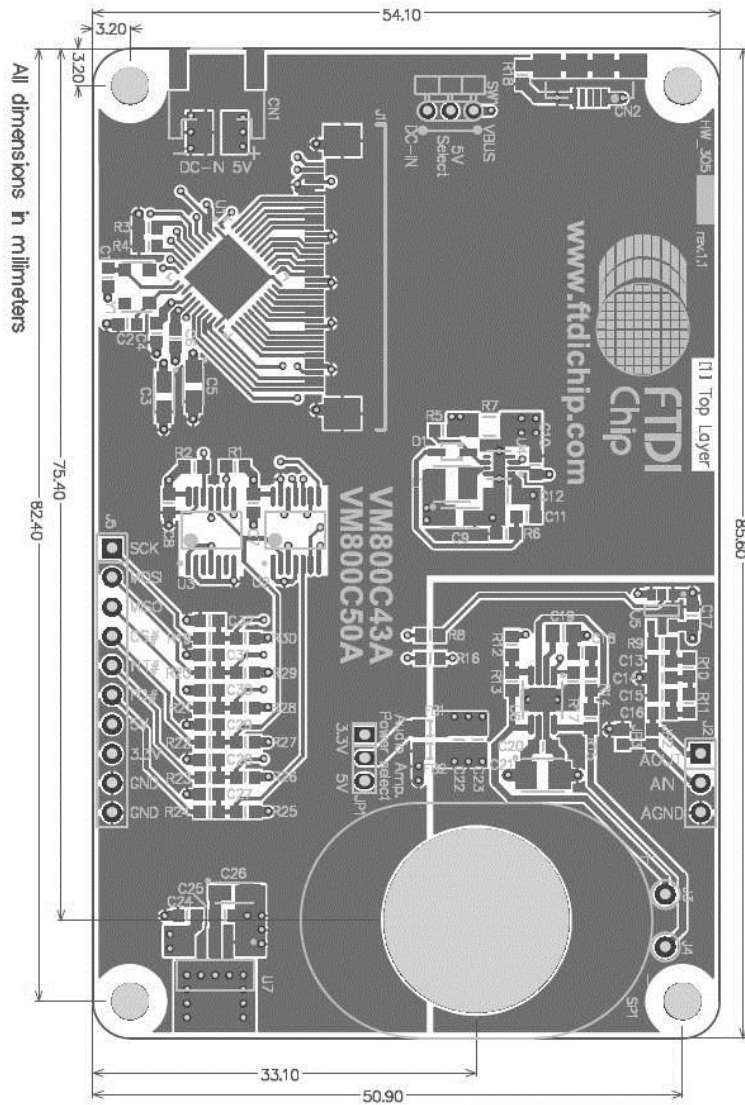

Figure 6-5 – VM800C50A PCB dimensions

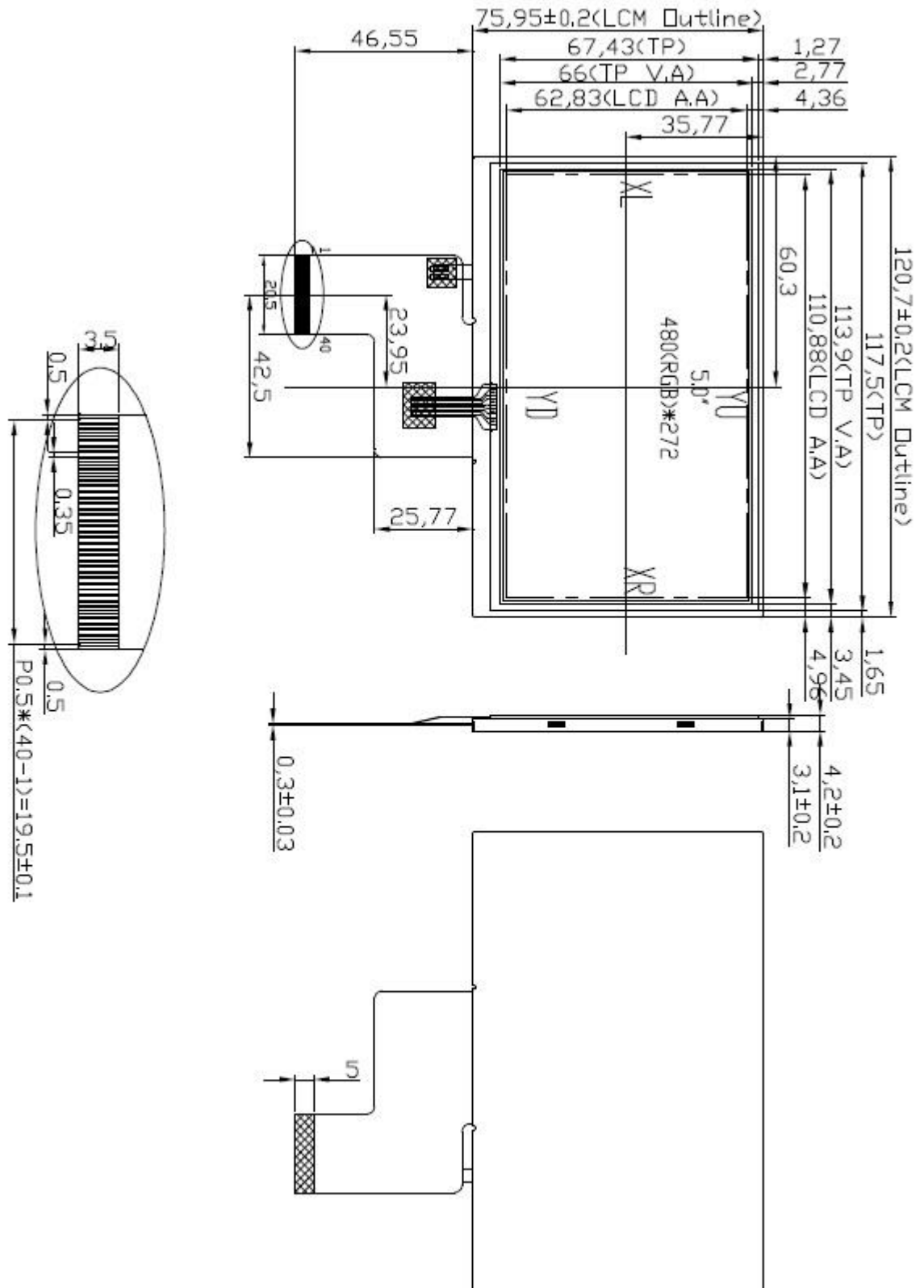

Figure 6-6 – VM800C50A Display dimensions

7 Specifications

7.1 Optical Specification

Item	Symbol	Condition	Min	Typ.	Max.	Unit
View Angles	θT	$CR \geq 10$	30	40		Degree
	θB		50	60		
	θL		50	60		
	θR		50	60		
Contrast Ratio	CR	$\theta = 0^\circ$		350		
Response Time	T_{on}	$25^\circ C$		25	40	ms
	T_{off}					
Chromaticity	White	x	0.260	0.310	0.360	
		y	0.283	0.333	0.383	
	RED	x	0.574	0.624	0.674	
		y	0.318	0.368	0.418	
	GREEN	x	0.300	0.350	0.400	
		y	0.500	0.550	0.600	
	BLUE	x	0.093	0.143	0.193	
		y	0.069	0.119	0.169	
Uniformity	U		75	80		%
NTSC				50		%
Luminance	L			500		cd/m ²

Table 7-1 - 3.5" TFT Optical specification

Item	Symbol	Condition	Min.	Typ.	Max.	Unit
Brightness	Bp	$\theta = 0^\circ$	-	350	-	Cd/m ²
Uniformity	ΔBp	$\Phi = 0^\circ$	70	80	-	%
Viewing Angle	3:00	$Cr \geq 10$	-	45	-	Deg
	6:00		-	20	-	
	9:00		-	45	-	
	12:00		-	40	-	
Contrast Ratio	Cr	$\theta = 0^\circ$ $\Phi = 0^\circ$	350	500		-
Response Time	T_r		-	10	-	ms
	T_f		-	10	-	ms
Color of CIE Coordinate	W	x		0.28		-
		y		0.33		-
	R	x		0.51		-
		y		0.34		-
	G	x		0.31		-
		y		0.56		-
	B	x		0.15		-
		y		0.14		-
NTSC Ratio	S		50	60	-	%

Table 7-2 - 4.3" TFT Optical Specification

Item	Symbol	Condition	Min.	Typ.	Max.	Unit
Brightness	Bp	$\theta=0^\circ$	200	250	-	Cd/m ²
Uniformity	Δ Bp	$\Phi=0^\circ$	70	80	-	%
Viewing Angle	3:00	$Cr \geq 10$	-	45	-	Deg
	6:00		-	25	-	
	9:00		-	45	-	
	12:00		-	45	-	
Contrast Ratio	Cr	$\theta=0^\circ$ $\Phi=0^\circ$	350	500	-	-
Response Time	T _r		-	10	-	ms
	T _f		-	10	-	ms
Color of CIE Coordinate	W	x	$\theta=0^\circ$ $\Phi=0^\circ$	0.28	-	-
		y		0.33	-	-
	R	x		0.51	-	-
		y		0.34	-	-
	G	x		0.31	-	-
		y		0.56	-	-
	B	x		0.15	-	-
		y		0.14	-	-
NTSC Ratio	S	50	60	-	%	

Table 7-3 - 5" TFT Optical Specification

8 Contact Information

Head Quarters – Singapore

Bridgetek Pte Ltd
178 Paya Lebar Road, #07-03
Singapore 409030
Tel: +65 6547 4827
Fax: +65 6841 6071

E-mail (Sales) sales.apac@brtchip.com
E-mail (Support) support.apac@brtchip.com

Branch Office – Taipei, Taiwan

Bridgetek Pte Ltd, Taiwan Branch
2 Floor, No. 516, Sec. 1, Nei Hu Road, Nei Hu District
Taipei 114
Taiwan, R.O.C.
Tel: +886 (2) 8797 5691
Fax: +886 (2) 8751 9737

E-mail (Sales) sales.apac@brtchip.com
E-mail (Support) support.apac@brtchip.com

Branch Office - Glasgow, United Kingdom

Bridgetek Pte. Ltd.
Unit 1, 2 Seaward Place, Centurion Business Park
Glasgow G41 1HH
United Kingdom
Tel: +44 (0) 141 429 2777
Fax: +44 (0) 141 429 2758

E-mail (Sales) sales.emea@brtchip.com
E-mail (Support) support.emea@brtchip.com

Branch Office – Vietnam

Bridgetek VietNam Company Limited
Lutaco Tower Building, 5th Floor, 173A Nguyen Van
Troj,
Ward 11, Phu Nhuan District,
Ho Chi Minh City, Vietnam
Tel : 08 38453222
Fax : 08 38455222

E-mail (Sales) sales.apac@brtchip.com
E-mail (Support) support.apac@brtchip.com

Web Site

<http://brtchip.com/>

Distributor and Sales Representatives

Please visit the Sales Network page of the [Bridgetek Web site](#) for the contact details of our distributor(s) and sales representative(s) in your country.

System and equipment manufacturers and designers are responsible to ensure that their systems, and any Future Technology Devices International Ltd (FTDI) devices incorporated in their systems, meet all applicable safety, regulatory and system-level performance requirements. All application-related information in this document (including application descriptions, suggested FTDI devices and other materials) is provided for reference only. While FTDI has taken care to assure it is accurate, this information is subject to customer confirmation, and FTDI disclaims all liability for system designs and for any applications assistance provided by FTDI. Use of FTDI devices in life support and/or safety applications is entirely at the user's risk, and the user agrees to defend, indemnify and hold harmless FTDI from any and all damages, claims, suits or expense resulting from such use. This document is subject to change without notice. No freedom to use patents or other intellectual property rights is implied by the publication of this document. Neither the whole nor any part of the information contained in, or the product described in this document, may be adapted or reproduced in any material or electronic form without the prior written consent of the copyright holder. Future Technology Devices International Ltd, Unit 1, 2 Seaward Place, Centurion Business Park, Glasgow G41 1HH, United Kingdom. Scotland Registered Company Number: SC136640

Appendix A - References

Document References

For module documentations, please refer to URL below:

www.ftdichip.com/VM800C.htm

FT800 datasheet: [DS_FT800_Embedded_Video_Engine](#)

FT800 software programming guide: [FT800_Programmer_Guide](#)

FT800 sample application notes:

[AN_245_VM800CB_SampleAPP_PC_Introduction](#)

[AN_246_VM800CB_SampleAPP_Arduino_Introduction](#)

C232HM-DDHSL-0 datasheet:

http://www.ftdichip.com/Support/Documents/DataSheets/Cables/DS_C232HM_MPSSE_CABLE.pdf

D2xx Programmers Guide:

[http://www.ftdichip.com/Support/Documents/ProgramGuides/D2XX_Programmer's_Guide\(FT_000071\).pdf](http://www.ftdichip.com/Support/Documents/ProgramGuides/D2XX_Programmer's_Guide(FT_000071).pdf)

AN_108: Command Processor for MPSSE and MCU Host Bus Emulation Modes

http://www.ftdichip.com/Support/Documents/AppNotes/AN_108_Command_Processor_for_MPSSE_and_MCU_Host_Bus_Emulation_Modes.pdf

Appendix B - List of Figures and Tables

List of Figures

Figure 3-1 – VM800C board profile 3.5” display version	4
Figure 3-2 - VM800C board profile 4.3”/5” display version	4
Figure 3-3 - VM800C module top view, 3.5 inch display version.....	6
Figure 4-1 - VM800C35 (3.5” Version).....	10
Figure 4-2 - VM800C43/VM800C50 (4.3”/5.0” Version)	11
Figure 4-3 – VM800C SPI Interface and IO.....	12
Figure 4-4 – VM800C Audio.....	13
Figure 5-1 – VM800C connects to PC via VA800A-SPI or MPSSE cable	15
Figure 6-1 – VM800C35A PCB dimensions.....	17
Figure 6-2 – VM800C35A Display dimensions	18
Figure 6-3 – VM800C43A PCB dimensions.....	19
Figure 6-4 – VM800C43A Display dimensions	20
Figure 6-5 – VM800C50A PCB dimensions.....	21
Figure 6-6 – VM800C50A Display dimensions	22

List of Tables

Table 2-1 – Ordering information.....	2
Table 3-1 LED backlight drive OVP and current.....	5
Table 3-2 – CN1 Pinout.....	6
Table 3-3 – CN2 Pinout.....	6
Table 3-4 – J1 Pinout	8
Table 3-5 – J2 Pin Options	8
Table 3-6 – J5 Pinout	9
Table 3-7 – JP1 Pin options	9
Table 3-8 – JP1 Pin options	9
Table 5-1 Board power configuration.....	14
Table 5-2 – MPSSE cable (C232HM-EDHSL-0) connection	16
Table 7-1 - 3.5” TFT Optical specification	23
Table 7-2 - 4.3” TFT Optical Specification	23
Table 7-3 - 5” TFT Optical Specification	24

Appendix C – Revision History

Document Title: VM800C Datasheet
 Document Reference No.: BRT_000003
 Clearance No.: BRT#005
 Product Page: <http://brtchip.com/product>
 Document Feedback: [Send Feedback](#)

Revision	Changes	Date
Version 1.0	Initial Release	2013-08-16
Version 1.1	Added Section 6 Mechanical Dimensions of PCBs and displays	2014-02-10
Version 1.2	Updated the optical characteristics for the 4.3" and 5" displays	2014-06-12
Version 1.3	Dual branding to reflect the migration of the product to the Bridgetek name – logo changed, copyright changed, contact information changed	2016-09-13