



晶采光電科技股份有限公司
AMPIRE CO., LTD.

SPECIFICATIONS FOR LCD MODULE

CUSTOMER	
CUSTOMER PART NO.	
AMPIRE PART NO.	AM-480272DTMQW-T00H
APPROVED BY	
DATE	

- Approved For Specifications
 Approved For Specifications & Sample

AMPIRE CO., LTD.
Building D., 2F., No.88, Sec. 1, Sintai 5th Rd., Sijhih City,
Taipei County 221, Taiwan (R.O.C.)
台北縣汐止市新台五路一段 88 號 2 樓(東方科學園區 D 棟)
TEL:886-2-26967269 , FAX:886-2-86967196 or 26967270

APPROVED BY	CHECKED BY	ORGANIZED BY

RECORD OF REVISION

Revision Date	Page	Contents	Editor
2007/4/24	-	New Release	Lorry
2007/6/28	-	Rename to AM-480272DTMQW-T00H	Edward
2007/7/27	-	Revised all T.B.D data.	Edward
2007/11/5	3	Correction the Brightness of Physical Specifications	Edward
2008/1/16	19	Modify the Chapter 10-5	Edward
	20	Correction the Outline Dimension	Edward

1. INTRODUCTION

This module is a color active matrix LCD module incorporating amorphous silicon TFT(Thin Film Transistor)It is composed of a color TFT-LCD panel, driver ICs, Input FPC and a back light unit. Graphics and text scan be displayed on a 480X3X272 dots panel with about 16million colors by supplying 24bit data signals (8bitXRGB),.

1.1. Features

- 16:9 diagonal configuration
- Resolution 480XRGBX272
- High brightness
- 4.0" Inch TFT-LCM

1.2. Applications

- PMP
- GPS
- GAME

2. PHYSICAL SPECIFICATIONS

Item	Specifications	unit
Display resolution(dot)	480RGB (W) x 272(H)	dots
Active area	87.84 (W) x 49.776 (H)	mm
Pixel pitch	0.183 (W) x 0.183 (H)	mm
Color configuration	R.G.B Vertical stripe	
Overall dimension	98.3(W)x62.6(H)x6.915(D)	mm
Weight	75	g
Surface treatment	Anti-glare	
Brightness	300	cd/m ²
Contrast ratio	350	
Backlight unit	LED	

3. BLOCK DIAGRAM

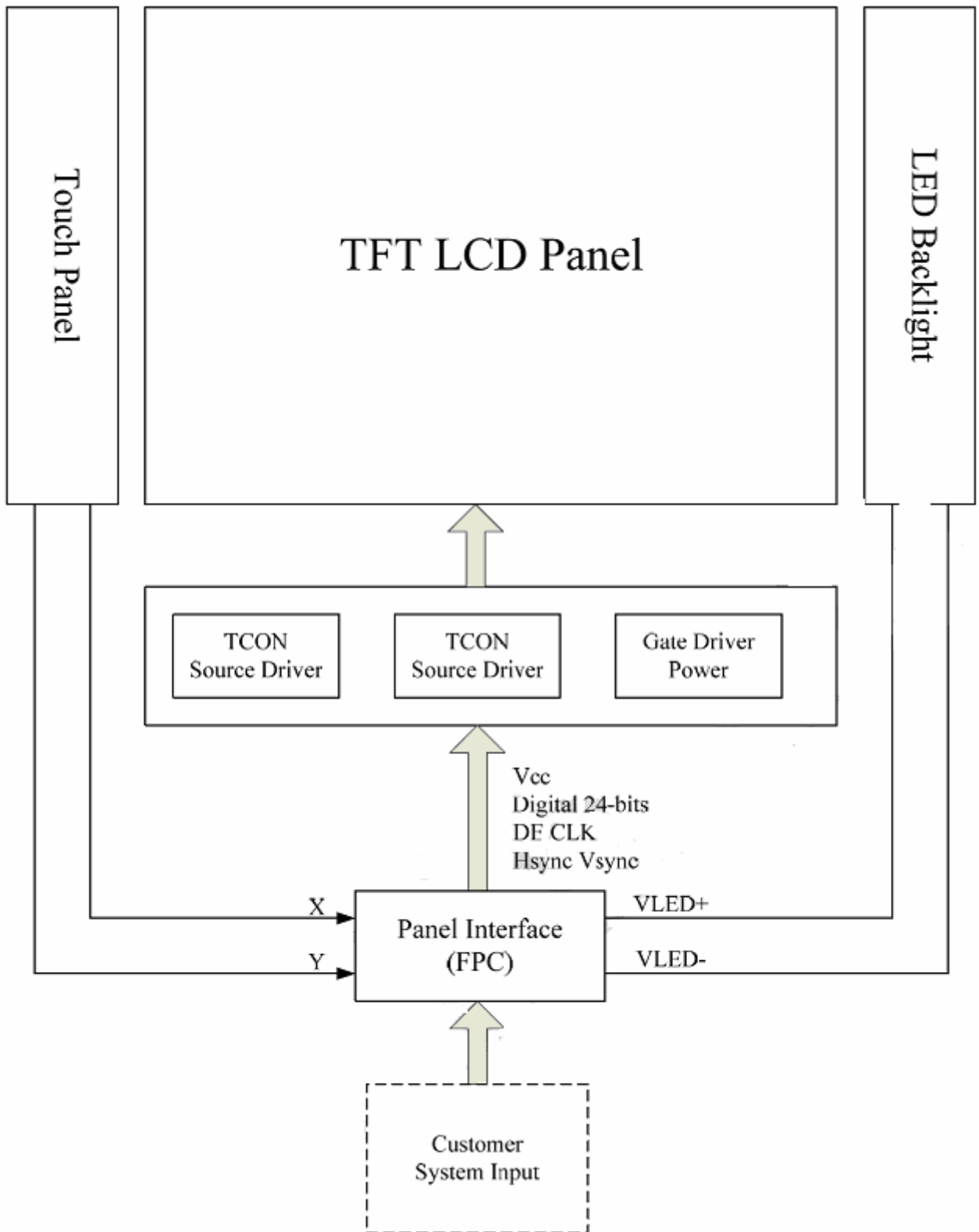

4. Electrical Specifications

4.1 TFT LCD Panel FPC Descriptions

Pin no	Symbol	Function
1	Vss	Ground
2	Vss	Ground
3	Vcc	Power Supply
4	Vcc	Power Supply
5	R0	Red Data Bit 0
6	R1	Red Data Bit 1
7	R2	Red Data Bit 2
8	R3	Red Data Bit 3
9	R4	Red Data Bit 4
10	R5	Red Data Bit 5
11	R6	Red Data Bit 6
12	R7	Red Data Bit 7
13	G0	Green Data Bit 0
14	G1	Green Data Bit 1
15	G2	Green Data Bit 2
16	G3	Green Data Bit 3
17	G4	Green Data Bit 4
18	G5	Green Data Bit 5
19	G6	Green Data Bit 6
20	G7	Green Data Bit 7
21	B0	Blue Data Bit 0
22	B1	Blue Data Bit 1
23	B2	Blue Data Bit 2
24	B3	Blue Data Bit 3
25	B4	Blue Data Bit 4
26	B5	Blue Data Bit 5
27	B6	Blue Data Bit 6
28	B7	Blue Data Bit 7
29	Vss	Ground
30	DCLK	Dot Data Clock
31	DISP	Display ON/OFF
32	Hsync	Horizontal Sync Input
33	Vsync	Vertical Sync Input
34	DE	Data Enable
35	U/D	Up/Down Control
36	L/R	Shift Right or Left Control
37	Vss	Ground
38	Vss	Ground
39	X1	Right(TP)
40	Y1	Bottom(TP)
41	X2	Left(TP)
42	Y2	UP(TP)
43	Vss	Ground
44	Vss	Ground
45	Vss	Ground
46	VLED-	LED Ground
47	VLED+	LED Power
48	Vss	Ground
49	Vss	Ground
50	Vss	Ground

4.2 ABSOLUTE MAXIMUM RATINGS

item	Symbol	Values		Unit	Remark
		Min	Max		
Power Voltage	VCC	-0.3	5.0	V	GND=0
Operation Temperature (Ambient)	T _{OP}	-30	80	°C	
Storage Temperature (Ambient)	T _{ST}	-40	85	°C	
LED Reverse Voltage	V _r		3.2	V	One LED
LED Forward current	I _f		23	mA	OneLED/Note2
LED Power Dissipation	P _d		64	mW	One LED

*TFT LCD Ratings

4.3 Power Voltage

item	Symbol	Values			Unit	Remark
		Min	Typ	Max		
Logic power supply	VCC	2.5	2.8	3.6		
Driver power supply	AVDD	4.8	5.0	5.2		

4.4 LED Back-light Electrical Specification

----- White LED Back-light Characteristics -----							
Parameter	Symbol	Condition	Min	Typ	Max	Unit	Note
Forward Current	IF	--	--	20	23	mA	Note 4
LCM Luminous intensity (Full White pattern)		IF=20mA	300	--	--	cd/m ²	Note 4
Forward Voltage	VF	IF=20mA	--	23.1	24.5	V	Note 5
LED C.I.E	X	IF=20mA	0.26	0.30	0.34		Note 6
	Y	IF=20mA	0.27	0.31	0.35		

Note 4: Luminous intensity is decided by forward current of White LED.

Note 5: White LEDs are with voltage tolerance.

Note 6: White LEDs are with color tolerance.

5. OPTICAL CHARACTERISTICS

Item	Symbol	Condition	Min.	Typ.	Max.	Unit	Note
Response Time	$T_r + T_f$	$\Theta = \Phi = 0^\circ$	-	(25)		ms	(3)
Contrast ratio	CR			350	-	-	(1)
Viewing Angle	Vertical	Θ	$CR \geq 10$	(110)	-	Deg.	(4)
	Horizontal	Φ		(130)	-		
Luminance	L	$\Theta = \Phi = 0^\circ$	300	-	-	cd/m ²	(2)
Color chromaticity	White		Wx	0.27	0.31	0.35	(2)(3)
			Wy	0.31	0.35	0.39	

NOTE :

Measure Condition: (IL= 20.0mA)

Measure Item Definition as follow :

(1) Definition of Contrast Ratio : (Measured by BM-7 (TOPCON) [dark room])

Contrast Ratio (CR)= (White) Luminance of ON ÷ (Black) Luminance of OFF

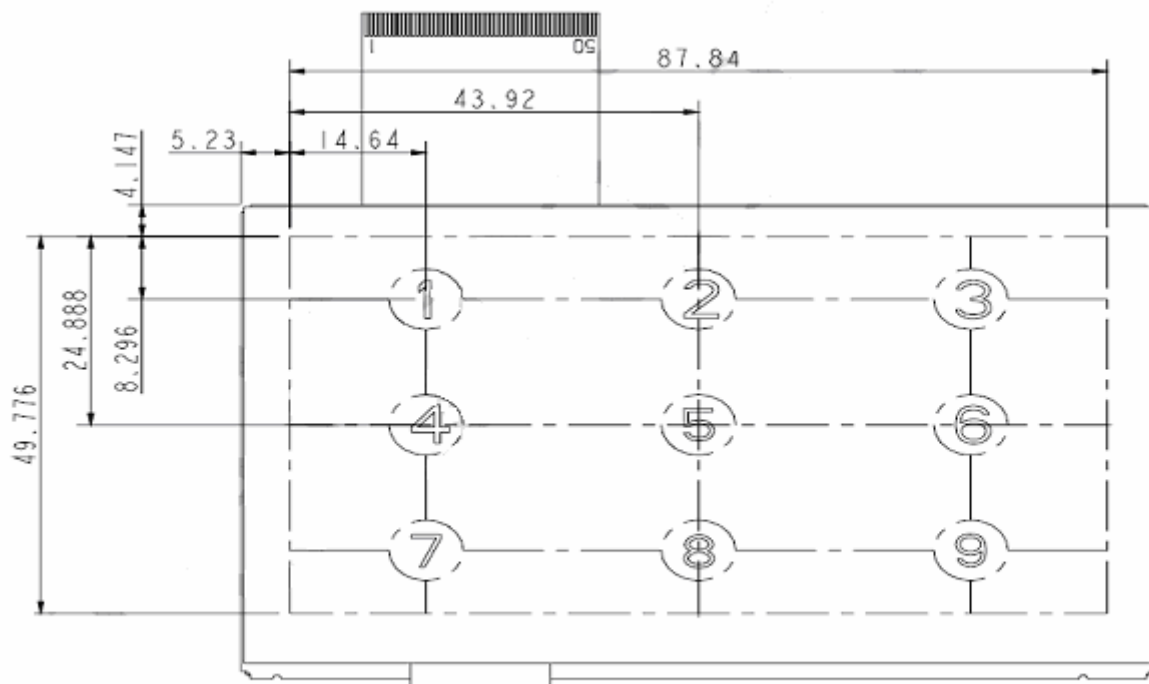

Fig.9-1: Test Point Position

(2) Definition of Center Luminance & Luminance Uniformity : (Measured by BM-7 (TOPCON) [dark room])

Center Luminance : Measure luminance on Point No5 as figure 9-1.

Luminance Uniformity : Measure maximum luminance(L(MAX))and minimum luminance (L(MIN))on the 9 points as figure 9-1.

$$L = [L(\text{MIN})/L(\text{MAX})] \times 100\% \Delta$$

(3) Response Time (White - Black)

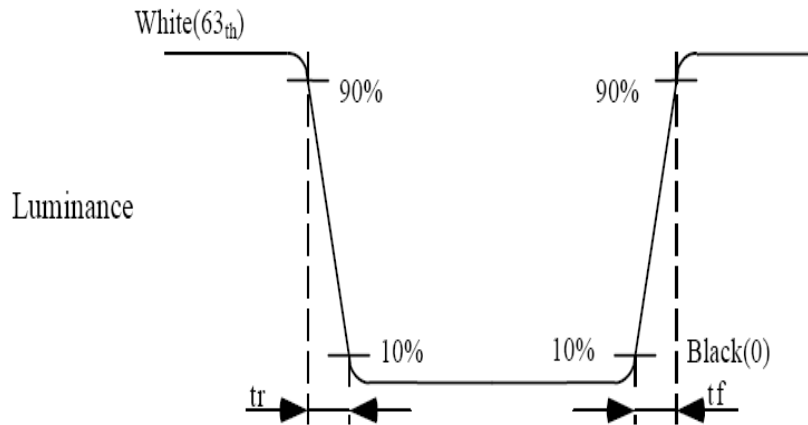
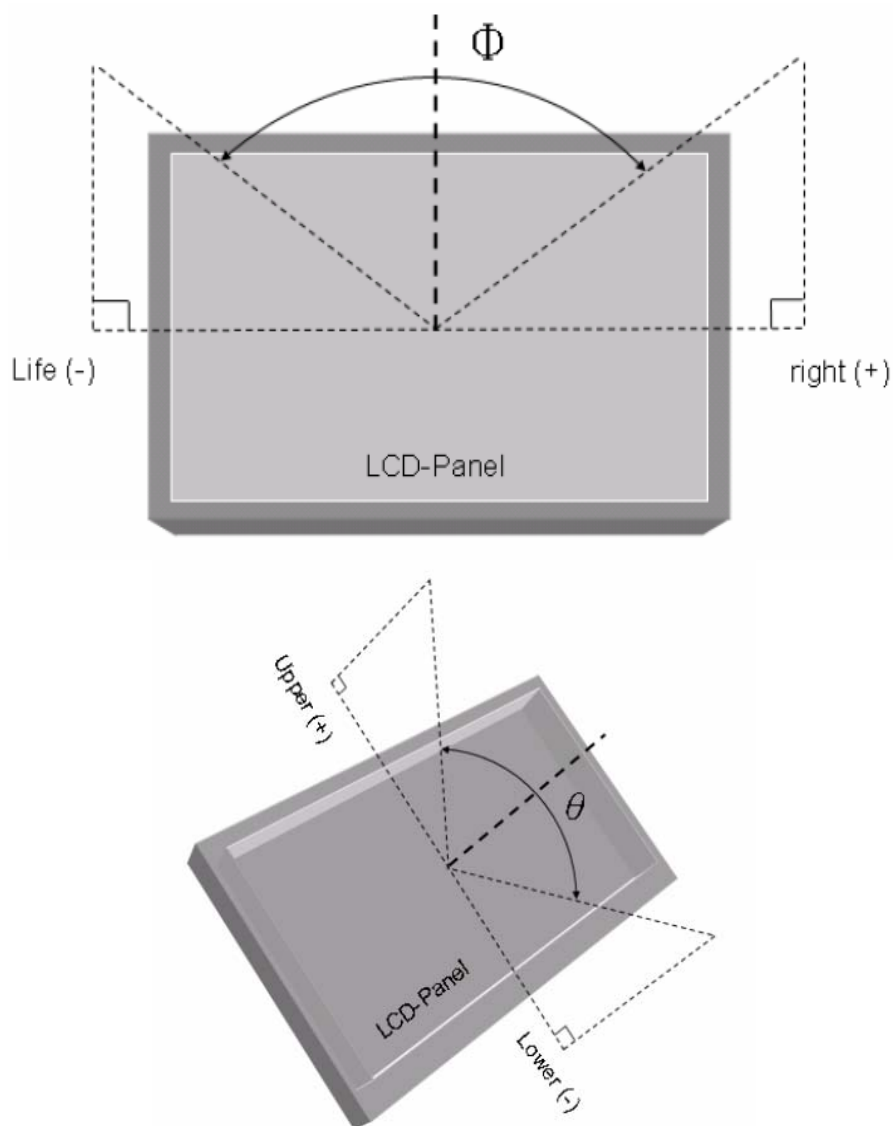

Fig.9-2: Definition of Response Time (White - Black)

(4) Definition of Viewing Angle.() : (by EZ-CONTRAST (ELDIM) in the dark room.)



6. INPUT SIGNAL

6.1 Timing Chart

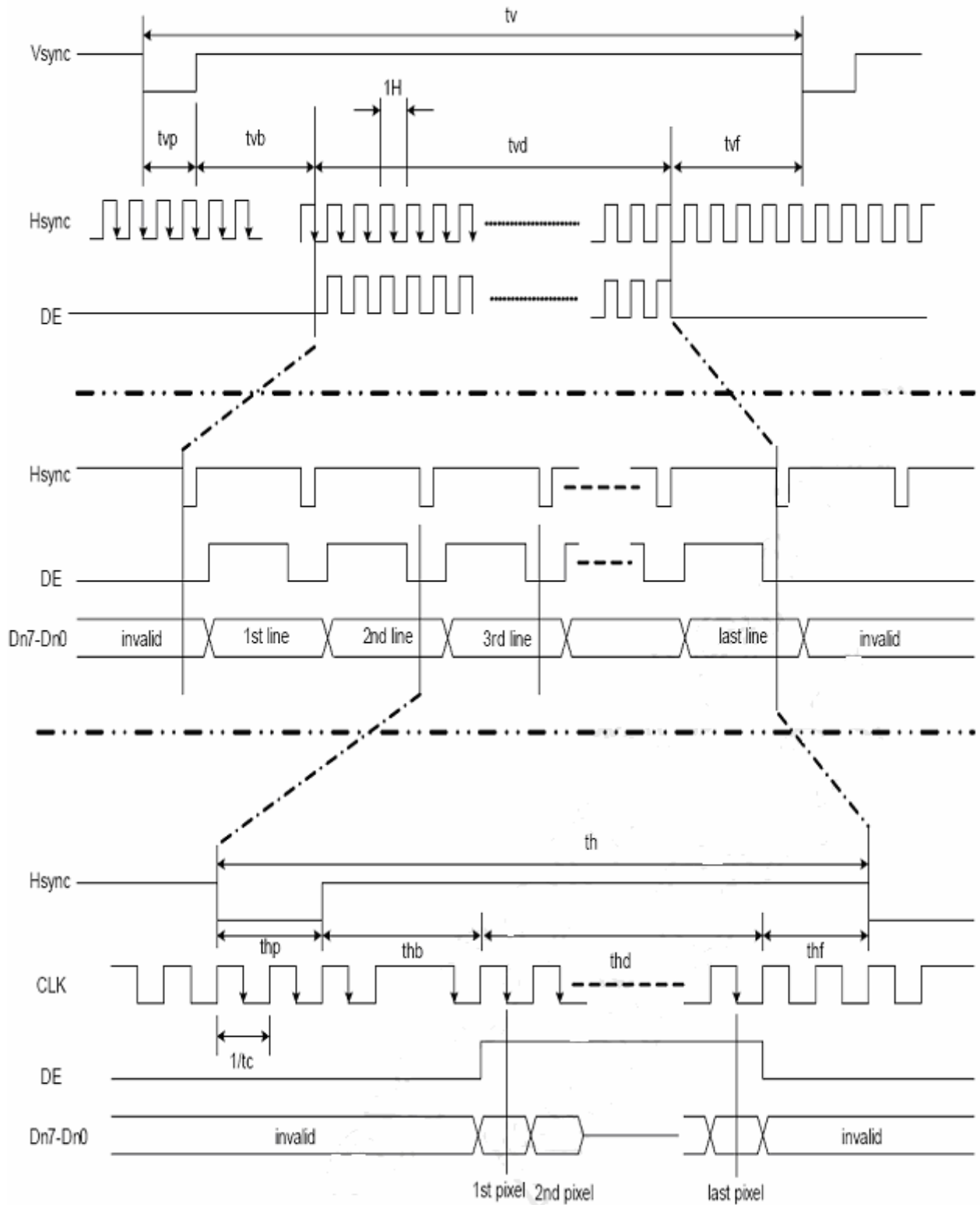

6.2 Timing Specification

PARAMETER	Symbol	Min.	Typ.	Max.	Unit
Clock cycle	$1/t_C$	-	9	15	MHz
Hsync cycle	$1/f_H$	-	17.14	-	KHz
Vsync cycle	$1/f_V$	-	59.94	-	Hz
Horizontal Signal					
Horizontal cycle	th	-	525	-	CLK
Horizontal display period	thd	-	480	-	CLK
Horizontal front porch	thf	2	-	-	CLK
Horizontal pulse width	thp	2	41	-	CLK
Horizontal back porch	thb	2	2	-	CLK
Vertical Signal					
Vertical cycle	tv	-	286	-	H
Vertical display period	tvd	-	272	-	H
Vertical front porch	tvf	1	2	-	H
Vertical pulse width	tvp	1	10	-	H
Vertical back porch	tvb	1	2	-	H

Note:

1. Parallel interface. Clock frequency and horizontal signal parameters are tripled in serial interface.
The Maximum clock frequency of serial interface is 33MHz
2. $thd=480CLK$, $thf=2CLK$, $thp=41CLK$, $thb=2CLK$, $thf + fhp + ftb > 44$

6.3 Timing Chart 2

PARAMETER	Symbol	Min.	Typ.	Max.	Unit
DISP setup time	t_{diss}	10	-	-	ns
DISP hold time	t_{dish}	10	-	-	ns
Clock period	PW_{CLK}^{*1}	66.7	-	-	ns
Clock pulse high period	PWH^{*1}	26.7	-	-	ns
Clock pulse low period	PWL^{*1}	26.7	-	-	ns
Hsync setup time	t_{hs}	10	-	-	ns
Hsync hold time	t_{hh}	10	-	-	ns
Data setup time	t_{ds}	10	-	-	ns
Data hold time	t_{dh}	10	-	-	ns
DE setup time	t_{des}	10	-	-	ns
DE hold time	t_{deh}	10	-	-	ns
Vsync setup time	t_{vhs}	10	-	-	ns
Vsync hold time	t_{vhh}	10	-	-	ns

Note:

1. For parallel interface, maximum clock frequency is 15MHz.
2. t_r , t_f is defined 10% to 90% of signal amplitude.

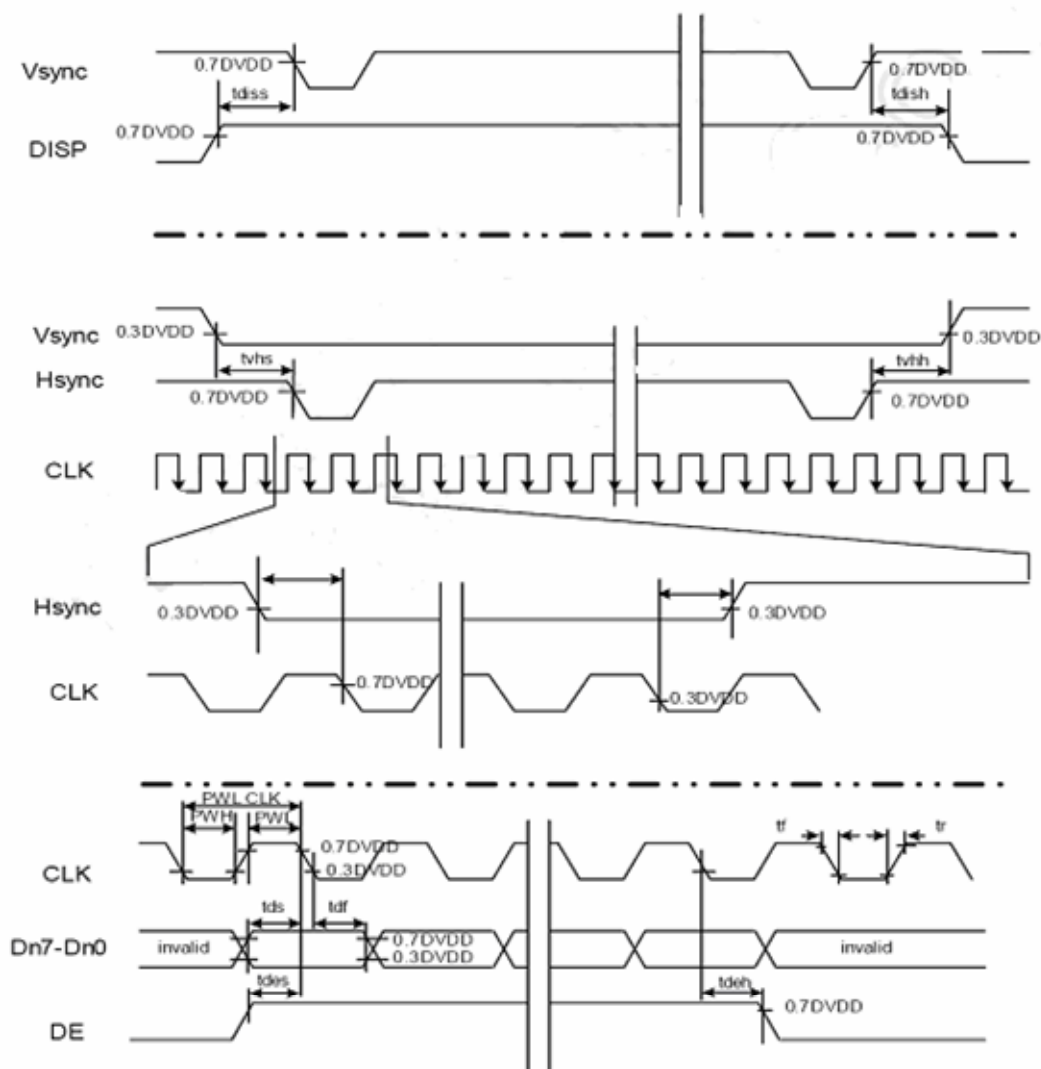

6.4 Color Data Assignment

COLOR	INPUT DATA	R DATA								G DATA								B DATA							
		R7	R6	R5	R4	R3	R2	R1	R0	G7	G6	G5	G4	G3	G2	G1	G0	B7	B6	B5	B4	B3	B2	B1	B0
		MSB							LSB	MSB							LSB	MSB							LSB
BASIC COLOR	BLACK	0	0	0	0	0	0	0	0	0	0	0	0	0	0	0	0	0	0	0	0	0	0	0	0
	RED(255)	1	1	1	1	1	1	1	1	0	0	0	0	0	0	0	0	0	0	0	0	0	0	0	0
	GREEN(255)	0	0	0	0	0	0	0	0	1	1	1	1	1	1	1	1	0	0	0	0	0	0	0	0
	BLUE(255)	0	0	0	0	0	0	0	0	0	0	0	0	0	0	0	0	1	1	1	1	1	1	1	1
	CYAN	0	0	0	0	0	0	0	0	1	1	1	1	1	1	1	1	1	1	1	1	1	1	1	1
	MAGENTA	1	1	1	1	1	1	1	1	0	0	0	0	0	0	0	0	1	1	1	1	1	1	1	1
	YELLOW	1	1	1	1	1	1	1	1	1	1	1	1	1	1	1	1	0	0	0	0	0	0	0	0
	WHITE	1	1	1	1	1	1	1	1	1	1	1	1	1	1	1	1	1	1	1	1	1	1	1	1
RED	RED(0)	0	0	0	0	0	0	0	0	0	0	0	0	0	0	0	0	0	0	0	0	0	0	0	0
	RED(1)	0	0	0	0	0	0	0	1	0	0	0	0	0	0	0	0	0	0	0	0	0	0	0	0
	RED(2)	0	0	0	0	0	0	1	0	0	0	0	0	0	0	0	0	0	0	0	0	0	0	0	0
	RED(254)	1	1	1	1	1	1	1	0	0	0	0	0	0	0	0	0	0	0	0	0	0	0	0	0
	RED(255)	1	1	1	1	1	1	1	1	0	0	0	0	0	0	0	0	0	0	0	0	0	0	0	0
GREEN	GREEN(0)	0	0	0	0	0	0	0	0	0	0	0	0	0	0	0	0	0	0	0	0	0	0	0	0
	GREEN(1)	0	0	0	0	0	0	0	0	0	0	0	0	0	0	1	0	0	0	0	0	0	0	0	0
	GREEN(2)	0	0	0	0	0	0	0	0	0	0	0	0	0	1	0	0	0	0	0	0	0	0	0	0
	GREEN(254)	0	0	0	0	0	0	0	0	1	1	1	1	1	1	0	0	0	0	0	0	0	0	0	0
	GREEN(255)	0	0	0	0	0	0	0	0	1	1	1	1	1	1	1	1	0	0	0	0	0	0	0	0
BLUE	BLUE(0)	0	0	0	0	0	0	0	0	0	0	0	0	0	0	0	0	0	0	0	0	0	0	0	0
	BLUE(1)	0	0	0	0	0	0	0	0	0	0	0	0	0	0	0	0	0	0	0	0	0	0	0	1
	BLUE(2)	0	0	0	0	0	0	0	0	0	0	0	0	0	0	0	0	0	0	0	0	0	0	1	0
	BLUE(254)	0	0	0	0	0	0	0	0	0	0	0	0	0	0	0	0	1	1	1	1	1	1	1	0
	BLUE(255)	0	0	0	0	0	0	0	0	0	0	0	0	0	0	0	0	1	1	1	1	1	1	1	1

7. TOUCH PANEL

7.1 ELECTRICAL CHARACTERISTICS

ITEM	MIN	TYP	MAX	UNIT	NOTE
Linearity error	-1.5	--	1.5	%	
Resistance Between Terminals *1)	500	--	1500	Ω	X (Film Side)
	200	--	900	Ω	Y (Glass Side)
Insulation Resistance	20M	--	--	Ω	DC 25V
Operation Voltage	--	--	5	V	
Response Time	--	--	10	ms	*2)
Transmittance	--	80	--	%	

[Note]

(1)Type : four-wire resistance

(2)

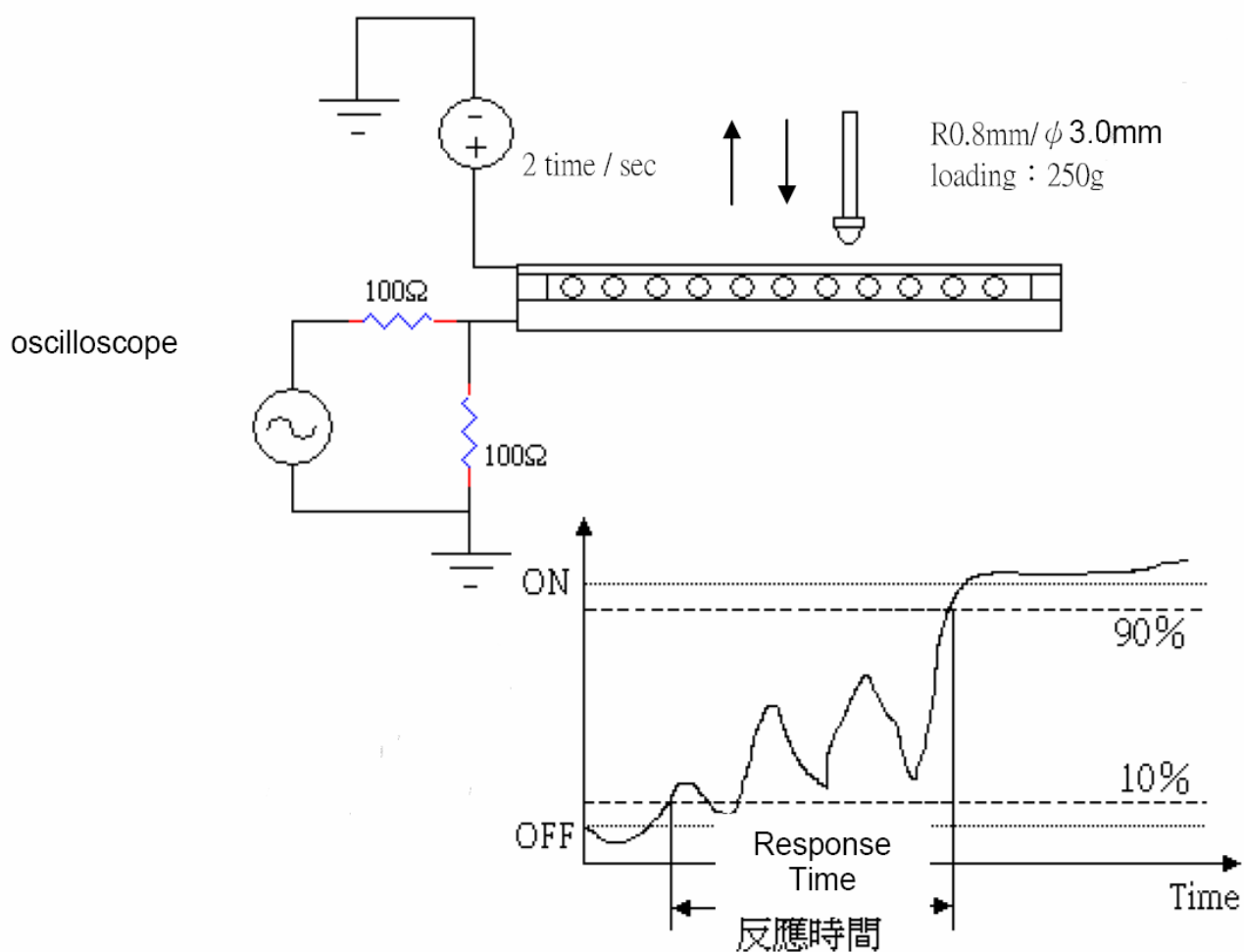

7.2 mechanical and reliability

Item	MIN	TYP	MAX	UNIT	NOTE
lowest. Activation Force	--	--	100	g	*1)
Durability-surface pitting	1,000,000			time	*2)
Durability-surface scratching	100,000			time	*3)
Surface Treatment	3			H	45°/4.9 Nt

(1) with stylus pen : R 0.8mm/φ3.0mm 、 with finger : R 8.0mm/φ12.0mm ◦

(2) writing with the Silicon Rubbe pen (R 8.0mm/φ12.0mm) on the same point of the touch panel with 250g force , frequency : 5Hz

(3) writing with the test pen (R 0.8/φ3.0mm/POM material) on the touch area of the touch panel with 250g (2.45N) force , moving velocity : 70mm/sec

7.3 Design guideline for Touch Panel

(a) The Housing Cushion on touch-panel must be set at outside of T.P's view-area ◦

(b) The Cushion material must be elastic material.

(c) The housing must avoid to touch the T.P

(d) To combine, the housing should not be stuck on T.P.

(e) 〈 Example of housing design 〉 :

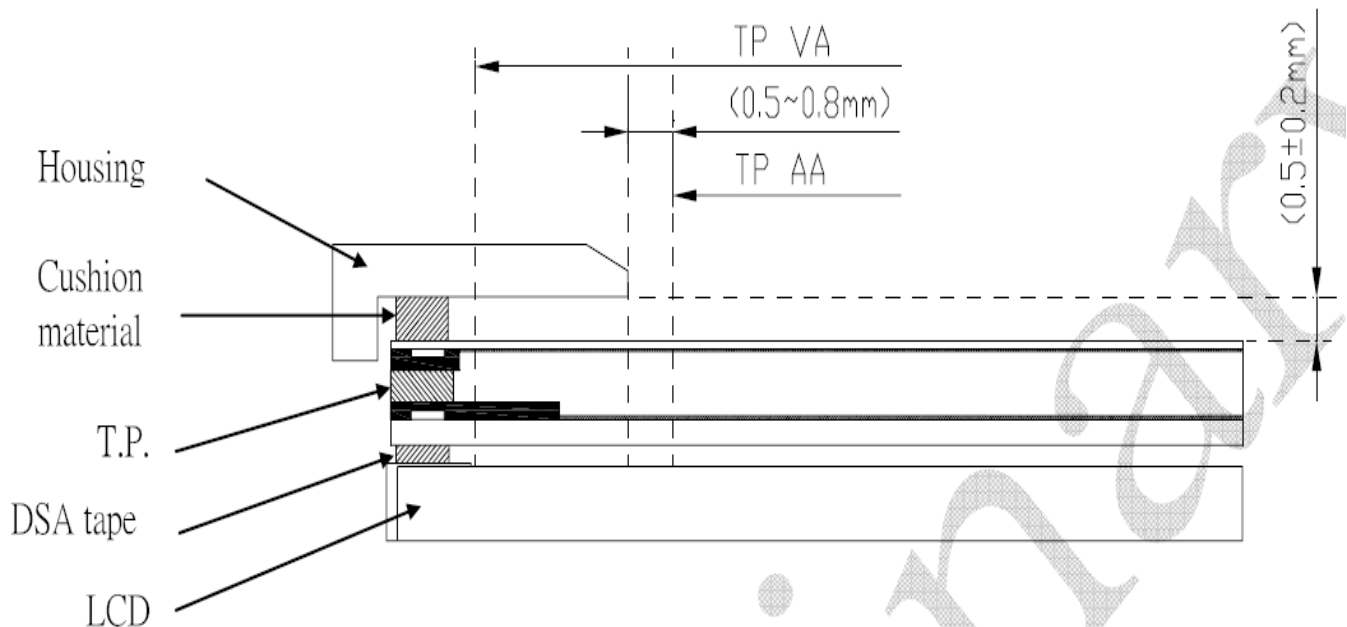

8. INSPECTION QUALITY CRITERIA

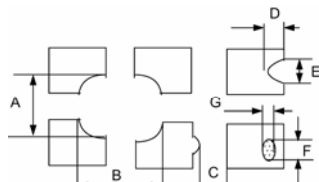
No.	Item	Criterion for defects	Class of Defect	Acceptable level										
1	Non display	No non display is allowed	Major	0.4										
2	Irregular operation	No irregular operation is allowed	Major	0.4										
3	Short	No short are allowed	Major	0.4										
4	Open	Any segments or common patterns that don't activate are rejectable.	Major	0.4										
5	Black/White spot (l)	<table border="1"> <thead> <tr> <th>Size D (mm)</th> <th>Acceptable number</th> </tr> </thead> <tbody> <tr> <td>$D \leq 0.1$</td> <td>Ignore</td> </tr> <tr> <td>$0.1 < D \leq 0.15$</td> <td>2 ※1</td> </tr> <tr> <td>$0.15 < D$</td> <td>0</td> </tr> </tbody> </table> <p>※1: The distance of two defects must be more than 20mm.</p>	Size D (mm)	Acceptable number	$D \leq 0.1$	Ignore	$0.1 < D \leq 0.15$	2 ※1	$0.15 < D$	0	Minor	1.5		
Size D (mm)	Acceptable number													
$D \leq 0.1$	Ignore													
$0.1 < D \leq 0.15$	2 ※1													
$0.15 < D$	0													
6	Dot Defect	<table border="1"> <tbody> <tr> <td>Bright dot</td> <td>1</td> </tr> <tr> <td>Dark dot</td> <td>$N \leq 3$</td> </tr> <tr> <td>Total dot defect (Bright dot + Dark dot)</td> <td>$N \leq 4$</td> </tr> <tr> <td>Minimum distance between dark dot and dark dot</td> <td>$0.1 < D \leq 0.3\text{mm}, N \leq 2$</td> </tr> </tbody> </table>	Bright dot	1	Dark dot	$N \leq 3$	Total dot defect (Bright dot + Dark dot)	$N \leq 4$	Minimum distance between dark dot and dark dot	$0.1 < D \leq 0.3\text{mm}, N \leq 2$	Minor	1.5		
Bright dot	1													
Dark dot	$N \leq 3$													
Total dot defect (Bright dot + Dark dot)	$N \leq 4$													
Minimum distance between dark dot and dark dot	$0.1 < D \leq 0.3\text{mm}, N \leq 2$													
7	Back Light	1. No Lighting is rejectable 2. Flickering and abnormal lighting are rejectable	Major	0.4										
8	Display pattern	 <p>Unit:mm</p> <table border="1"> <tbody> <tr> <td>$\frac{A+B}{2} \leq 0.30$</td> <td>$0 < C$</td> <td>$\frac{D+E}{2} \leq 0.25$</td> <td>$\frac{F+G}{2} \leq 0.25$</td> </tr> </tbody> </table> <p>Note: 1. Acceptable up to 3 damages 2. NG if there're to two or more pinholes per dot</p>	$\frac{A+B}{2} \leq 0.30$	$0 < C$	$\frac{D+E}{2} \leq 0.25$	$\frac{F+G}{2} \leq 0.25$	Minor	1.5						
$\frac{A+B}{2} \leq 0.30$	$0 < C$	$\frac{D+E}{2} \leq 0.25$	$\frac{F+G}{2} \leq 0.25$											
9	Blemish & Foreign matters Size: $D = \frac{A+B}{2}$	<table border="1"> <thead> <tr> <th>Size D (mm)</th> <th>Acceptable number</th> </tr> </thead> <tbody> <tr> <td>$D \leq 0.15$</td> <td>Ignore</td> </tr> <tr> <td>$0.15 < D \leq 0.20$</td> <td>3</td> </tr> <tr> <td>$0.20 < D \leq 0.30$</td> <td>2</td> </tr> <tr> <td>$0.30 < D$</td> <td>0</td> </tr> </tbody> </table>	Size D (mm)	Acceptable number	$D \leq 0.15$	Ignore	$0.15 < D \leq 0.20$	3	$0.20 < D \leq 0.30$	2	$0.30 < D$	0	Minor	1.5
Size D (mm)	Acceptable number													
$D \leq 0.15$	Ignore													
$0.15 < D \leq 0.20$	3													
$0.20 < D \leq 0.30$	2													
$0.30 < D$	0													

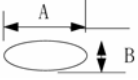
10	Scratch on Polarizer 	<table border="1"> <thead> <tr> <th>Width (mm)</th> <th>Length (mm)</th> <th>Acceptable number</th> </tr> </thead> <tbody> <tr> <td>$W \leq 0.03$</td> <td>$L \leq 2.0$</td> <td>2</td> </tr> </tbody> </table>	Width (mm)	Length (mm)	Acceptable number	$W \leq 0.03$	$L \leq 2.0$	2	Minor	1.5
		Width (mm)	Length (mm)	Acceptable number						
$W \leq 0.03$	$L \leq 2.0$	2								
Note: The distance of two defects must be more than 20mm.										
11	Bubble in polarizer	<p>Zone A Active area : No bubble are allowed.</p> <p>Zone B Viewing area: $\leq 0.05\text{mm}^2$, $N \leq 1$</p>	Minor	1.5						
12	Stains on LCD panel surface	Stains that cannot be removed even when wiped lightly with a soft cloth or similar cleaning too are rejectable.	Minor	1.5						
13	Rust in Bezel	Rust which is visible in the bezel is rejectable.	Minor	1.5						
14	Defect of land surface contact (poor soldering)	Evident crevices which is visible are rejectable.	Minor	1.5						
15	Parts mounting	<ol style="list-style-type: none"> 1. Failure to mount parts 2. Parts not in the specifications are mounted 3. Polarity, for example, is reversed 	Major Major Major	0.4						
16	Parts alignment	1. LSI, IC lead width is more than 50% beyond pad outline.	Minor	1.5						
		2. Chip component is off center and more than 50% of the leads is off the pad outline.	Minor							
17	Conductive foreign matter (Solder ball, Solder chips)	1. $0.45 < \varphi$, $N \geq 1$	Major	0.4						
		2. $0.30 < \varphi \leq 0.45$, $N \geq 1$	Minor	1.5						
		φ : Average diameter of solder ball (unit: mm) 3. $0.50 < L$, $N \geq 1$ L: Average length of solder chip (unit: mm)	Minor	1.5						
18	Faulty PCB correction	1. Due to PCB copper foil pattern burnout, the pattern is connected, using a jumper wire for repair; 2 or more places are corrected per PCB.	Minor	1.5						
		2. Short circuited part is cut, and no resist coating has been performed.	Minor							

9. RELIABILITY TEST CONDITIONS

ITEM	CONDITIONS	NOTE
HIGH TEMPERATURE OPERATION	80°C , 240Hrs	
HIGH TEMPERATURE AND HIGH HUMIDITY OPERATION	60°C , 90%RH , 240Hrs	
HIGH TEMPERATURE STORAGE	85°C , 240Hrs	
LOW TEMPERATURE OPERATION	-30°C , 240Hrs	
LOW TEMPERATURE STORAGE	-40°C , 240Hrs	
THERMAL SHOCK	-30°C(1Hr) ~80°C(1Hr) 200Cycle	

10. USE PRECAUTIONS

10-1 Handling precautions

- (1) The polarizing plate may break easily so be careful when handling it. Do not touch, press or rub it with a hard-material tool like tweezers.
- (2) Do not touch the polarizing plate surface with bare hands so as not to make it dirty. If the surface or other related part of the polarizing plate is dirty, soak a soft cotton cloth or chamois leather in benzine and wipe off with it. Do not use chemical liquids such as acetone, toluene and isopropyl alcohol. Failure to do so may bring chemical reaction phenomena and deteriorations.
- (3) Remove any spit or water immediately. If it is left for hours, the suffered part may deform or decolorize.
- (1) If the LCD element breaks and any LC stuff leaks, do not suck or lick it. Also if LC stuff is stuck on your skin or clothing, wash thoroughly with soap and water immediately.

10-2 Installing precautions

- (1) The PCB has many ICs that may be damaged easily by static electricity. To prevent breaking by static electricity from the human body and clothing, earth the human body properly using the high resistance and discharge static electricity during the operation. In this case, however, the resistance value should be approx. 1M Ω and the resistance should be placed near the human body rather than the ground surface. When the indoor space is dry, static electricity may occur easily so be careful. We recommend the indoor space should be kept with humidity of 60% or more. When a soldering iron or other similar tool is used for assembly, be sure to earth it.
- (2) When installing the module and ICs, do not bend or twist them. Failure to do so may crack LC element and cause circuit failure.
- (3) To protect LC element, especially polarizing plate, use a transparent protective plate (e.g., acrylic plate, glass etc) for the product case.
- (4) Do not use an adhesive like a both-side adhesive tape to make LCD surface (polarizing plate) and product case stick together. Failure to do so may cause the polarizing plate to peel off

10-3 Storage precautions

- (1) Avoid a high temperature and humidity area. Keep the temperature between 0°C and 35°C and also the humidity under 60%.
- (2) Choose the dark spaces where the product is not exposed to direct sunlight or fluorescent light.
- (3) Store the products as they are put in the boxes provided from us or in the same conditions as we recommend.

10-4 Operating precautions

- (1) Do not boost the applied drive voltage abnormally. Failure to do so may break ICs. When applying power voltage, check the electrical features beforehand and be careful. Always turn off the power to the LC module controller before removing or inserting the LC module input connector. If the input connector is removed or inserted while the power is turned on, the LC module internal circuit may break.
- (2) The display response may be late if the operating temperature is under the normal standard, and the display may be out of order if it is above the normal standard. But this is not a failure; this will be restored if it is within the normal standard.
- (3) The LCD contrast varies depending on the visual angle, ambient temperature, power voltage etc. Obtain the optimum contrast by adjusting the LC drive voltage.
- (4) When carrying out the test, do not take the module out of the low-temperature space suddenly. Failure to do so will cause the module condensing, leading to malfunctions.
- (5) Make certain that each signal noise level is within the standard (L level: 0.2V_{dd} or less and H level: 0.8V_{dd} or more) even if the module has functioned properly. If it is beyond the standard, the module may often malfunction. In addition, always connect the module when making noise level measurements.
- (6) The CMOS ICs are incorporated in the module and the pull-up and pull-down function is not adopted for the input so avoid putting the input signal open while the power is ON.
- (7) The characteristic of the semiconductor element changes when it is exposed to light emissions, therefore ICs on the LCD may malfunction if they receive light emissions. To prevent these malfunctions, design and assemble ICs so that they are shielded from light emissions.
- (8) Crosstalk occurs because of characteristics of the LCD. In general, crosstalk occurs when the regularized display is maintained. Also, crosstalk is affected by the LC drive voltage. Design the contents of the display, considering crosstalk.

10-5 Other

- (1) Do not disassemble or take the LC module into pieces. The LC modules once disassembled or taken into pieces are not the guarantee articles.
- (2) The residual image may exist if the same display pattern is shown for hours. This residual image, however, disappears when another display pattern is shown or the drive is interrupted and left for a while. But this is not a problem on reliability.
- (3) AMIPRE will provide one year warranty for all products and three months warranty for all repairing products.

11. OUTLINE DIMENSION

