

STANDARD

標準品

- Standard series for general purpose
標準品通用型
- High performance and high reliability
高性能與高可靠
- Load life of 2000 hours at 85°C
在 85°C 環境中負荷壽命 2000 小時
- Comply with the RoHS directive
符合 RoHS 指令

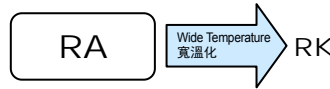

SPECIFICATIONS 特性表

Items 項目	Characteristics 主要特性	
Operation Temperature Range 使用溫度範圍	-40 ~ +85°C	-25 ~ +85°C
Voltage Range 額定工作電壓範圍	6.3 ~ 100V	160 ~ 450V
Capacitance Range 靜電容量範圍	0.1 ~ 22000µF	0.47 ~ 470µF
Capacitance Tolerance 靜電容量允許偏差	±20% at 120Hz, 20°C	
Leakage Current 漏電流	Leakage current = 0.01CV or 3µA, whichever is greater (after 2 minutes application of rated voltage) 漏電流 = 0.01CV 或 3µA, 取較大值 (施加額定工作電壓 2 分鐘後)	Leakage current = 0.02CV + 15µA (after 5 minutes application of rated voltage) 漏電流 = 0.02CV + 15µA (施加額定工作電壓 5 分鐘後)
Dissipation Factor (tan δ) 損耗角正切	When nominal capacitance is over 1000µF, tan δ shall be added 0.02 to the listed value with increase of every 1000µF. 當標稱靜電容量大於 1000µF, 其標稱靜電容量每增加 1000µF, 損耗角正切增加 0.02. Measurement frequency 測試頻率: 120Hz, Temperature 溫度: 20°C	
Stability at Low Temperature 低溫特性	Measurement frequency 測試頻率: 120Hz	
	Rated Voltage (V) 額定工作電壓	6.3 10 16 25 35 50 63 100 160~250 350~450
Load Life 高溫負荷特性	After 2000 hours application of the rated voltage at 85°C, they meet the characteristics listed below. 在 85°C 環境中施加額定工作電壓 2000 小時後, 電容器的特性符合下表的要求。	
	Capacitance Change 靜電容量變化率	Within ±20% of initial measured value 初始值的±20%以內
Shelf Life 高溫貯存特性	After leaving capacitors under no load at 85°C for 1000 hours, they meet the specified value for load life characteristics listed above. 在 85°C 環境中無負荷放置 1000 小時後, 電容器的特性符合高溫負荷特性中所列的規定值。	
	Dissipation Factor 損耗角正切	≤200% of initial specified value 不大於規範值的 200%
Marking 標識	Printed with white colour on navy blue sleeve (PVC) or printed with white colour on green sleeve (PET). 深藍色膠管白字印刷 (PVC) 或綠色膠管白字印刷 (PET)。	
	Leakage Current 漏電流	≤initial specified value 不大於規範值

DRAWING (Unit: mm) 外形圖

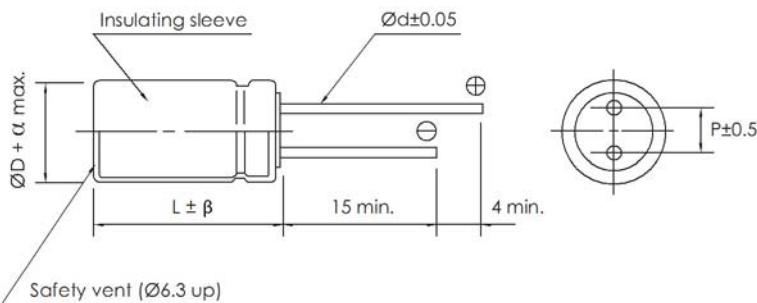

ØD	5	6.3	8 (L≤11.5)	8 (L≥16)	10	13	16	18	22	25
P	2.0	2.5	3.5		5.0	7.5	10.0	12.5		
Ød	0.5		0.6			0.8				
β	1.5					2.0				
α	0.5								1.0	

FREQUENCY COEFFICIENT OF ALLOWABLE RIPPLE CURRENT 紋波電流頻率補償係數

Frequency 頻率	50Hz	120Hz	300Hz	1KHz	10KHz~
Coefficient 係數	0.75	1.0	1.35	1.55	2.0
0.1 ~ 47µF	0.80	1.0	1.25	1.34	1.5
68 ~ 680µF	0.85	1.0	1.10	1.13	1.15
1000 ~ 22000µF					

Note: All design and specifications are for reference only and is subject to change without prior notice. If any doubt about safety for your application, please contact us immediately for technical assistance before purchase.

注: 以上所提供的設計及特性參數僅供參考, 任何修改不作預先通知。如果在使用上有疑問, 請在採購前與我們聯繫, 以便提供技術上的協助。

CAT.2014/V5

□ DIMENSIONS & MAXIMUM PERMISSIBLE RIPPLE CURRENT 規格尺寸及最大允許紋波電流

WV Code 代碼	6.3		10		16		25		35		50		63		
	0J		1A		1C		1E		1V		1H		1J		
0.1	0R1											5 × 11	6.4	5 × 11	7
0.22	R22											5 × 11	9.5	5 × 11	11
0.33	R33											5 × 11	11	5 × 11	13
0.47	R47											5 × 11	14	5 × 11	15
0.68	R68											5 × 11	17	5 × 11	19
1	010											5 × 11	20	5 × 11	22
2.2	2R2											5 × 11	29	5 × 11	34
3.3	3R3											5 × 11	35	5 × 11	40
4.7	4R7											5 × 11	42	5 × 11	48
6.8	6R8											5 × 11	50	5 × 11	60
10	100					5 × 11	50	5 × 11	65	5 × 11	60	5 × 11	65	5 × 11	70
22	220			5 × 11	50	5 × 11	55	5 × 11	90	5 × 11	95	5 × 11	100	5 × 11	120
33	330			5 × 11	65	5 × 11	85	5 × 11	95	5 × 11	110	5 × 11 (6.3×11.5)	125 (136)	6.3 × 11.5	145
47	470			5 × 11	80	5 × 11	90	5 × 11	115	5 × 11	130	6.3 × 11.5	165	6.3 × 11.5	170
68	680			5 × 11	80	5 × 11	104	5 × 11	140	6.3 × 11.5	170	6.3 × 11.5	195	8 × 11.5	245
100	101	5 × 11	134	5 × 11	140	5 × 11	180	5 × 11	190	6.3 × 11.5	210	8 × 11.5	260	8 × 11.5	370
220	221	5 × 11	200	5 × 11	220	6.3 × 11.5	260	6.3 × 11.5	330	8 × 11.5	385	8 × 16 (10×12)	425 (482)	10 × 16	490
330	331	6.3 × 11.5	240	6.3 × 11.5	290	6.3 × 11.5 (8×11.5)	300 (340)	8 × 11.5	440	10 × 12	490	10 × 16	585	10 × 20	710
470	471	6.3 × 11.5	340	6.3 × 11.5 (8×11.5)	350 (410)	8 × 11.5	440	8 × 11.5 (8×16)	530 (550)	10 × 16	740	10 × 20	755	13 × 21	900
680	681	8 × 11.5	468	8 × 11.5	470	8 × 16	560	10 × 16	645	10 × 20	930	13 × 21	925	13 × 25	1100
1000	102	8 × 11.5	580	8 × 16 (10×12)	550 (650)	8 × 16 (10×16)	770 (845)	10 × 16 (10×20)	860 (955)	13 × 21	1145	13 × 25	1340	16 × 25 (16×31)	1300 (1450)
2200	222	8 × 20 (10×16)	660 (845)	10 × 20	1070	10 × 20	1210	13 × 21 (13×25)	1300 (1540)	16 × 25	1400	16 × 31 (18×35)	1700 (2100)	18 × 35	2040
3300	332	10 × 20	1185	13 × 21	1420	13 × 25	1400	13 × 21 (16×25)	1500 (1600)	16 × 31	2070	18 × 35	2500	22 × 40	2575
4700	472	13 × 21	1545	13 × 25	1780	16 × 25	1700	16 × 31	2100	16 × 31 (18×35)	2200 (2700)	22 × 40	3040	25 × 40	3200
6800	682	13 × 25	1880	16 × 25	1870	16 × 31	2100	18 × 35	2550	22 × 35	2900	25 × 40	3185		
10000	103	16 × 31	2215	16 × 35	2250	18 × 35	2590	22 × 40	3080						
15000	153	18 × 31	2250	18 × 35	2820	22 × 40	3100								
22000	223	22 × 40	3140												

WV Code 代碼	100		160		200		250		350		400		450		
	2A		2C		2D		2E		2V		2G		2W		
0.1	0R1	5 × 11	7.2												
0.22	R22	5 × 11	11												
0.33	R33	5 × 11	13												
0.47	R47	5 × 11	16	5 × 11	12	5 × 11	12	5 × 11	12	6.3 × 11.5	16	6.3 × 11.5	17		
0.68	R68	5 × 11	20	5 × 11	15	5 × 11	15	5 × 11	15	6.3 × 11.5	20	6.3 × 11.5	20		
1	010	5 × 11	25	5 × 11	18	5 × 11	18	6.3 × 11.5	20	6.3 × 11.5	24	6.3 × 11.5	24	8 × 11.5	28
2.2	2R2	5 × 11	33	6.3 × 11.5	25	6.3 × 11.5	33	6.3 × 11.5	33	6.3 × 11.5	37	8 × 11.5	37	8 × 11.5 (10×12)	45 (55)
3.3	3R3	5 × 11	40	6.3 × 11.5	35	6.3 × 11.5	46	6.3 × 11.5	46	8 × 11.5	50	8 × 11.5	50	10 × 12	65
4.7	4R7	5 × 11	48	6.3 × 11.5	42	6.3 × 11.5	50	8 × 11.5	55	8 × 11.5	60	10 × 12	80	10 × 16	90
6.8	6R8	5 × 11	55	8 × 11.5	58	8 × 11.5	67	8 × 11.5	77	10 × 12	85	10 × 16	100	10 × 20	125
10	100	5 × 11	65	10 × 12	75	10 × 12	85	10 × 12 (10×16)	100 (125)	10 × 16	110	10 × 20	120	13 × 21	168
22	220	6.3 × 11.5	124	10 × 16	130	10 × 16	135	10 × 20	150	13 × 21	190	13 × 21 (13×25)	200 (235)	13 × 25	300
33	330	8 × 11.5	177	10 × 16	175	10 × 20	180	13 × 21	215	13 × 25	275	13 × 25	275	16 × 25	320
47	470	10 × 12	235	13 × 21	235	13 × 21	250	13 × 21	290	16 × 25	380	16 × 25	360	16 × 31	390
68	680	10 × 16	293	13 × 21	330	13 × 25	340	16 × 25	380	16 × 31	450	16 × 35	435	16 × 35	460
100	101	10 × 20	405	13 × 25	440	16 × 25	460	16 × 25	510	18 × 35	620	18 × 35	586	18 × 40	580
220	221	13 × 25	640	16 × 31	790	16 × 35 (18×31)	830 (850)	18 × 35	890						
330	331	13 × 25	757	18 × 31	970	18 × 35	1150								
470	471	16 × 25	910	18 × 40	1150										
680	681	16 × 31	1365												
1000	102	18 × 40	1820											Case size 尺寸	Ripple current 紋波電流

•Case size ØD×L(mm), ripple current (mA rms) at 85°C, 120Hz •尺寸ØD×L(mm), 紋波電流(mA rms)於 85°C, 120Hz

- Please refer to page 16 "Taping Specifications" & page 18 "Lead Forming & Cutting" about the taped or formed product spec. 編帶與引線成型標準請參閱第 16 頁 "編帶標準" 及 "第 18 頁引線成型與剪腳"。
- Please refer to page 17 "Packaging Specifications" for the minimum package quantity. 最小包裝數量請參閱第 17 頁 "包裝標準"。

Note: All design and specifications are for reference only and is subject to change without prior notice. If any doubt about safety for your application, please contact us immediately for technical assistance before purchase.

注：以上所提供的設計及特性參數僅供參考，任何修改不作預先通知。如果在使用上有疑問，請在採購前與我們聯繫，以便提供技術上的協助。

CAT.2014/V5