



晶采光電科技股份有限公司
AMPIRE CO., LTD.

SPECIFICATIONS FOR LCD MODULE

CUSTOMER	
CUSTOMER PART NO.	
AMPIRE PART NO.	AC-404AYILY-75H-B(R)
APPROVED BY	
DATE	

- Approved For Specifications
- Approved For Specifications & Sample

AMPIRE CO., LTD.

**2F., No.88, Sec. 1, Sintai 5th Rd., Sijhih City, Taipei County 221,
Taiwan (R.O.C.)台北縣汐止市新台五路一段88號2樓(東方科學園區D棟)
TEL:886-2-26967269 , FAX:886-2-26967196 or 26967270**

APPROVED BY	CHECKED BY	ORGANIZED BY

RECORD OF REVISION

Revision Date	Page	Contents	Editor
2008/11/5	--	New Release	Edward

1 FEATURES

- (1) Display format : 40 characters × 4 lines
- (2) Construction : LCD, Bezel, Yellow-green LED back-light and PCB.
- (3) Display type : STN , Yellow-green mode ,Transflective , 6 o'clock view.
- (4) Controller : ST7066U-0T or Equivalent.
- (5) 5V single power input.
- (6) Extended temperature type.
- (7) Excellent LC : VOP maintains at 5V for whole temp. range, no need extra temp. compensation circuit.
- (8) ROHS compliant.

2 MECHANICAL DATA

Parameter	Stand Value	Unit
Dot size	0.50(W) × 0.55(H)	mm
Dot pitch	0.57(W) × 0.62(H)	mm
Character size	2.78(W) × 4.89(H)	mm
Viewing area	147.0(W) × 29.5(H)	mm
Module size (LED back-light)	190.0(W) × 54.0(H) × 14.0 max (T)	mm

3 ABSOLUTE MAXIMUM RATINGS

Parameter	Symbol	Min	Max	Unit	
Logic Circuit Supply Voltage	VDD-VSS	-0.3	7.0	V	
LCD Driving Voltage	VDD-VO	-0.3	10.0	V	
Input Voltage	VI	-0.3	VDD+0.3	V	
Extended temp. type	Operating Temp.	TOP	-20	70	°C
	Storage Temp.	TSTG	-30	80	°C

4 ELECTRO-OPTICAL CHARACTERISTICS

Parameter	Symbol	Condition	Min	Typ	Max	Unit	Note
----- Electronic Characteristics -----							
Logic Circuit Supply Voltage	VDD-VSS	--	4.5	5.0	5.5	V	
LCD Driving Voltage	VDD-VO	-20 °C	4.75	5.0	5.25	V	
		25 °C	4.75	5.0	5.25		
		70 °C	4.75	5.0	5.25		
Input Voltage	VIH	--	0.7 VDD	--	VDD	V	
	VIL	--	VSS	--	0.3 VDD	V	
Logic Supply Current	IDD	VDD = 5V	--	3.0	4.0	mA	
----- Optical Characteristics -----							
Contrast	CR	25°C	--	5	--		Note 1
Rise Time	tr	25°C	--	150	200	ms	Note 2
Fall Time	tf	25°C	--	150	200	ms	
Viewing Angle Range	θ f	25°C & CR≥2	--	35	--	Deg.	Note 3
	θ b		--	30	--		
	θ l		--	30	--		
	θ r		--	30	--		
Frame Frequency	fF	25°C	--	64	--	Hz	
----- LED Back-light Characteristics -----							
Forward Voltage	VF	IF=600mA	--	4.1	4.3	V	Supply Voltage between A&K
Forward Current	IF	--	--	600	--	mA	
LCM Luminous intensity		IF=600mA	--	30	--	cd/m ²	

* LED Dice number = 2×60=120

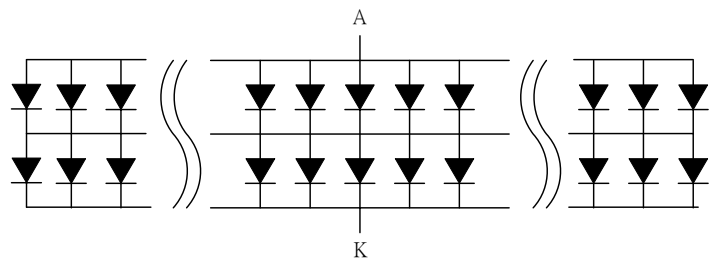

(NOTE 1) Contrast ratio :

$$CR = (\text{Brightness in OFF state}) / (\text{Brightness in ON state})$$

(NOTE 2) Response time :

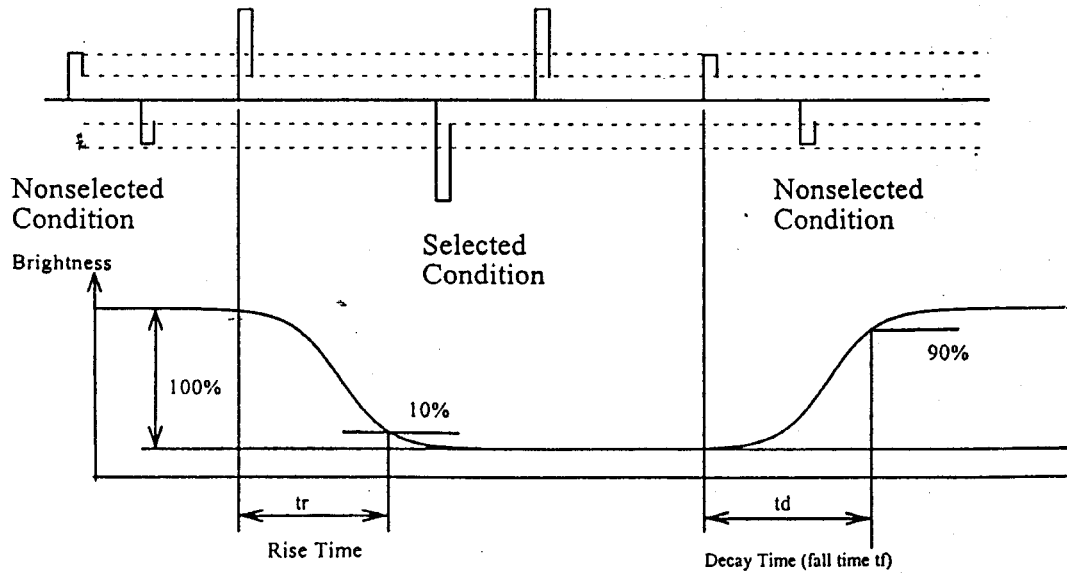

(NOTE 3) Viewing angle

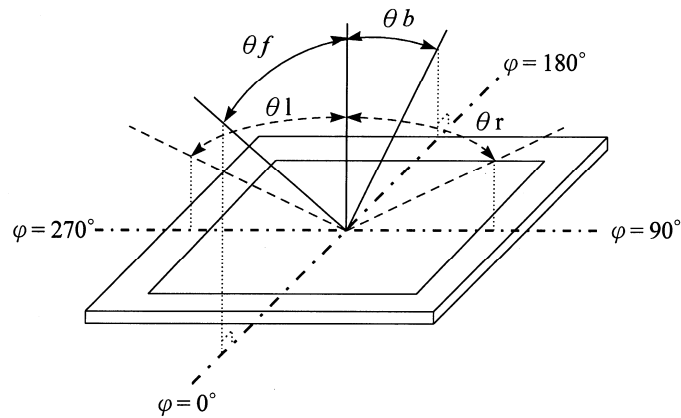

5 BLOCK DIAGRAM & INTERFACE

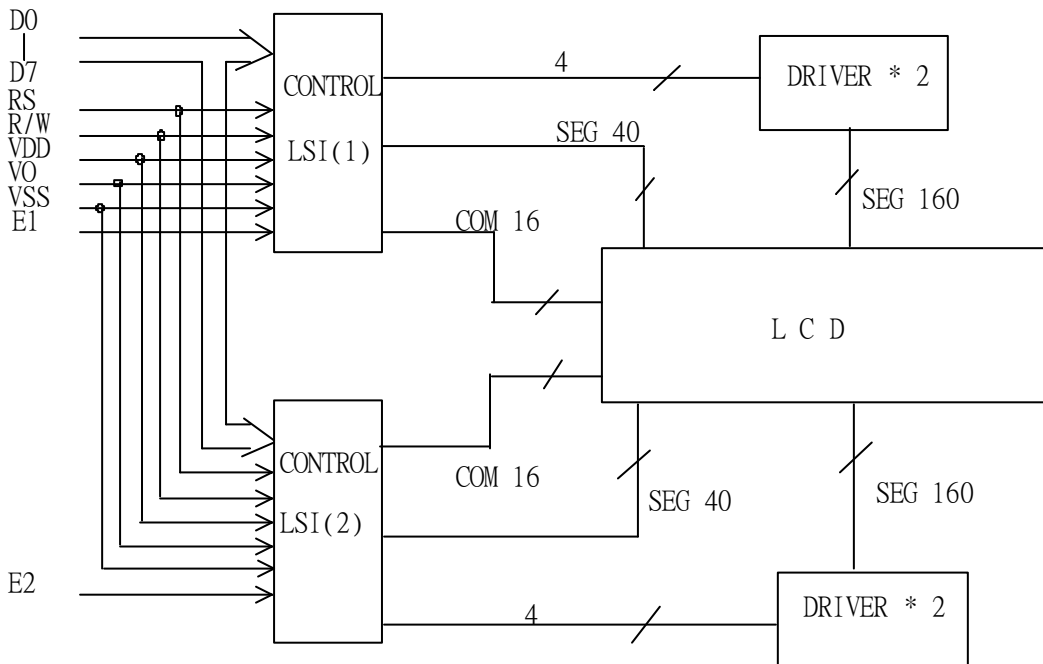

No.	Symbol	Function
1	DB7	Data Bus
2	DB6	Data Bus
3	DB5	Data Bus
4	DB4	Data Bus
5	DB3	Data Bus
6	DB2	Data Bus
7	DB1	Data Bus
8	DB0	Data Bus
9	E1	Enable Signal
10	R/W	Read/Write Select
11	RS	Data/Instruction Select
12	VO	Contrast Adjustment
13	VSS	Ground (0V)
14	VDD	Supply Voltage for Logic (+5V)
15	E2	Enable Signal (no pull-up resistor)
16	NC	No connection

6 POWER SUPPLY

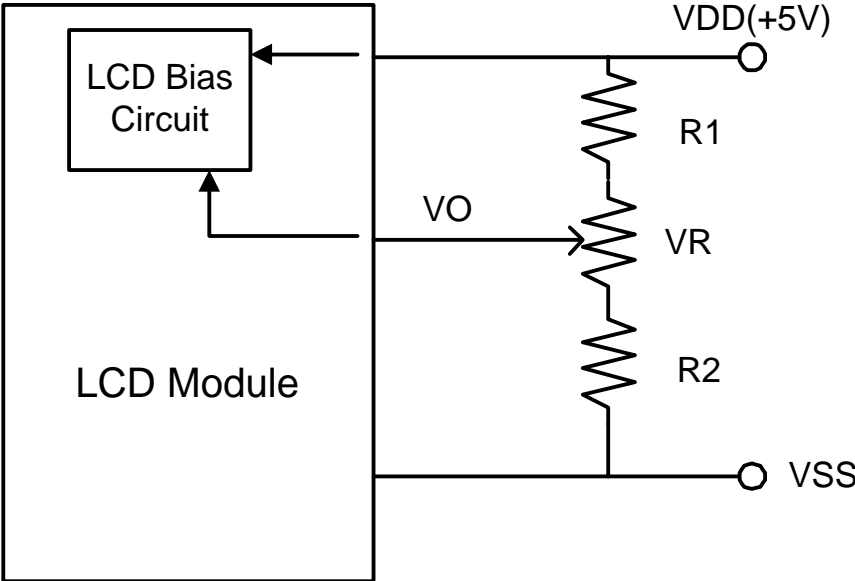

5V Power Input

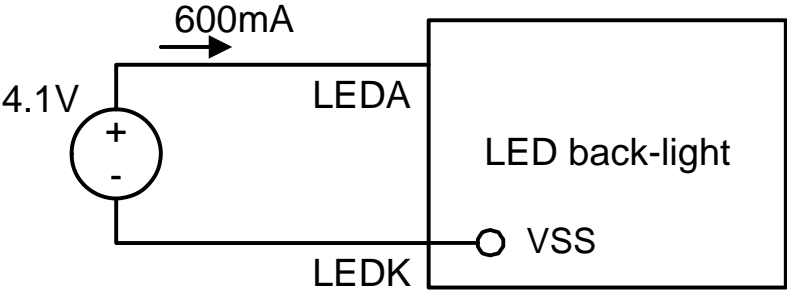

7 TIMING CHARACTERISTICS

Write Operation

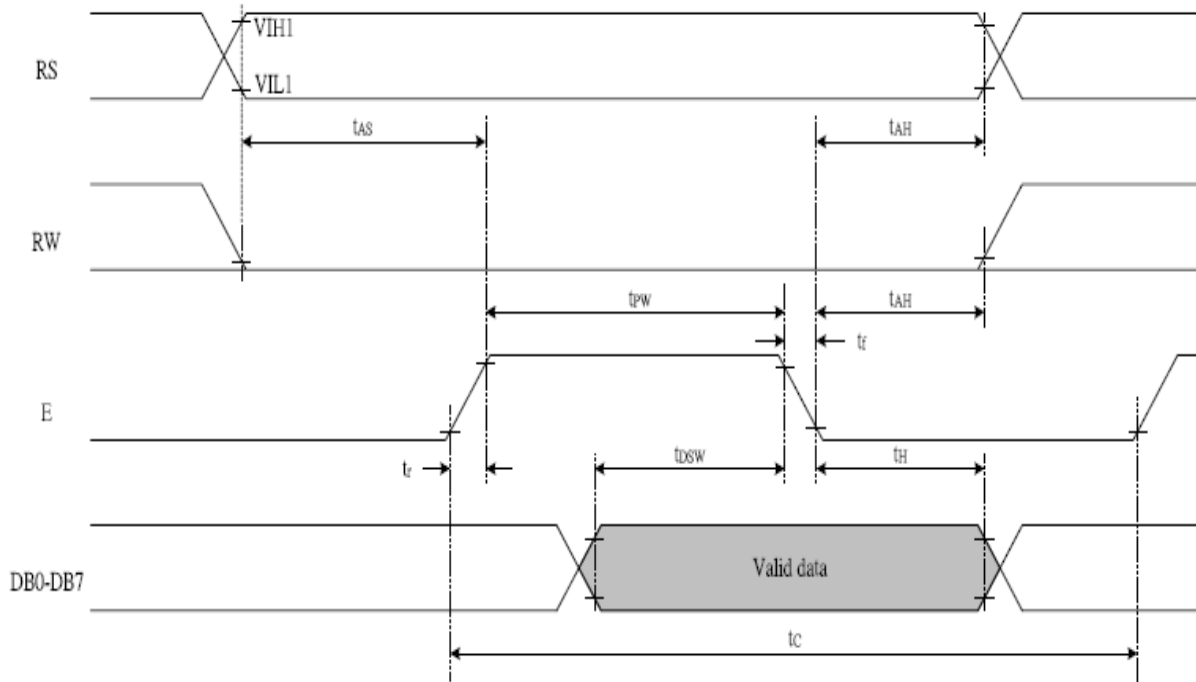

VDD = 5.0V

Symbol	Characteristics	Test Condition	Min.	Max.	Unit
<i>Write Mode (Writing data from MPU to ST7066U)</i>					
T_C	Enable Cycle Time	Pin E	1200	-	ns
T_{PW}	Enable Pulse Width	Pin E	140	-	ns
T_R, T_F	Enable Rise/Fall Time	Pin E	-	25	ns
T_{AS}	Address Setup Time	Pins: RS, RW, E	0	-	ns
T_{AH}	Address Hold Time	Pins: RS, RW, E	10	-	ns
T_{DSW}	Data Setup Time	Pins: DB0 - DB7	40	-	ns
T_H	Data Hold Time	Pins: DB0 - DB7	10	-	ns

Read Operation

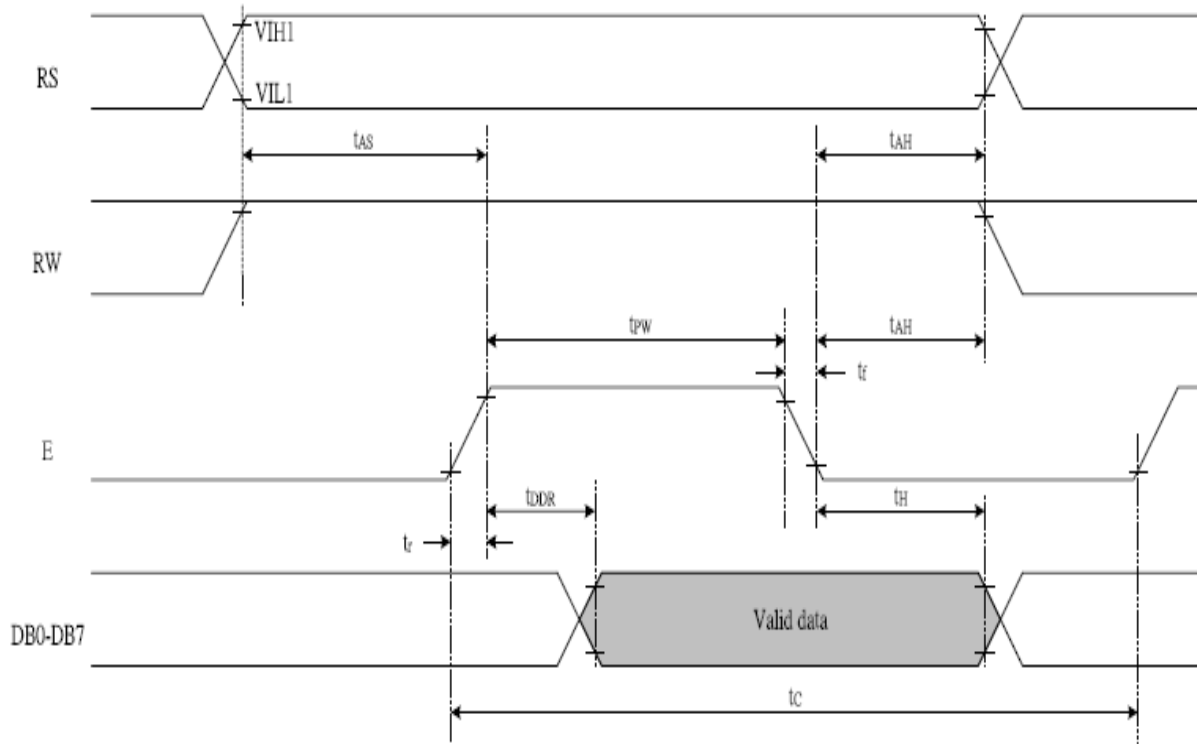

VDD = 5.0V

Symbol	Characteristics	Test Condition	Min.	Max.	Unit
<i>Read Mode (Reading Data from ST7066U to MPU)</i>					
T_C	Enable Cycle Time	Pin E	1200	-	ns
T_{PW}	Enable Pulse Width	Pin E	140	-	ns
T_{R}, T_{F}	Enable Rise/Fall Time	Pin E	-	25	ns
T_{AS}	Address Setup Time	Pins: RS, RW, E	0	-	ns
T_{AH}	Address Hold Time	Pins: RS, RW, E	10	-	ns
T_{DDR}	Data Setup Time	Pins: DB0 - DB7	-	100	ns
T_H	Data Hold Time	Pins: DB0 - DB7	10	-	ns

8 INSTRUCTION SET

Instruction	Instruction Code										Description	Description Time (270KHz)
	RS	R/W	DB7	DB6	DB5	DB4	DB3	DB2	DB1	DB0		
Clear Display	0	0	0	0	0	0	0	0	0	1	Write "20H" to DDRAM. and set DDRAM address to "00H" from AC	1.52 ms
Return Home	0	0	0	0	0	0	0	0	1	x	Set DDRAM address to "00H" from AC and return cursor to its original position if shifted. The contents of DDRAM are not changed.	1.52 ms
Entry Mode Set	0	0	0	0	0	0	0	1	I/D	S	Sets cursor move direction and specifies display shift. These operations are performed during data write and read.	37 us
Display ON/OFF	0	0	0	0	0	0	1	D	C	B	D=1:entire display on C=1:cursor on B=1:cursor position on	37 us
Cursor or Display Shift	0	0	0	0	0	1	S/C	R/L	x	x	Set cursor moving and display shift control bit, and the direction, without changing DDRAM data.	37 us
Function Set	0	0	0	0	1	DL	N	F	x	x	DL:interface data is 8/4 bits N:number of line is 2/1 F:font size is 5x11/5x8	37 us
Set CGRAM address	0	0	0	1	AC5	AC4	AC3	AC2	AC1	AC0	Set CGRAM address in address counter	37 us
Set DDRAM address	0	0	1	AC6	AC5	AC4	AC3	AC2	AC1	AC0	Set DDRAM address in address counter	37 us
Read Busy flag and address	0	1	BF	AC6	AC5	AC4	AC3	AC2	AC1	AC0	Whether during internal operation or not can be known by reading BF. The contents of address counter can also be read.	0 us
Write data to RAM	1	0	D7	D6	D5	D4	D3	D2	D1	D0	Write data into internal RAM (DDRAM/CGRAM)	37 us
Read data from RAM	1	1	D7	D6	D5	D4	D3	D2	D1	D0	Read data from internal RAM (DDRAM/CGRAM)	37 us

Note:

Be sure the ST7066U is not in the busy state (BF = 0) before sending an instruction from the MPU to the ST7066U. If an instruction is sent without checking the busy flag, the time between the first instruction and next instruction will take much longer than the instruction time itself. Refer to Instruction Table for the list of each instruction execution time.

9 INITIALIZATION SEQUENCE

- 8-bit Interface (fosc=270KHz)

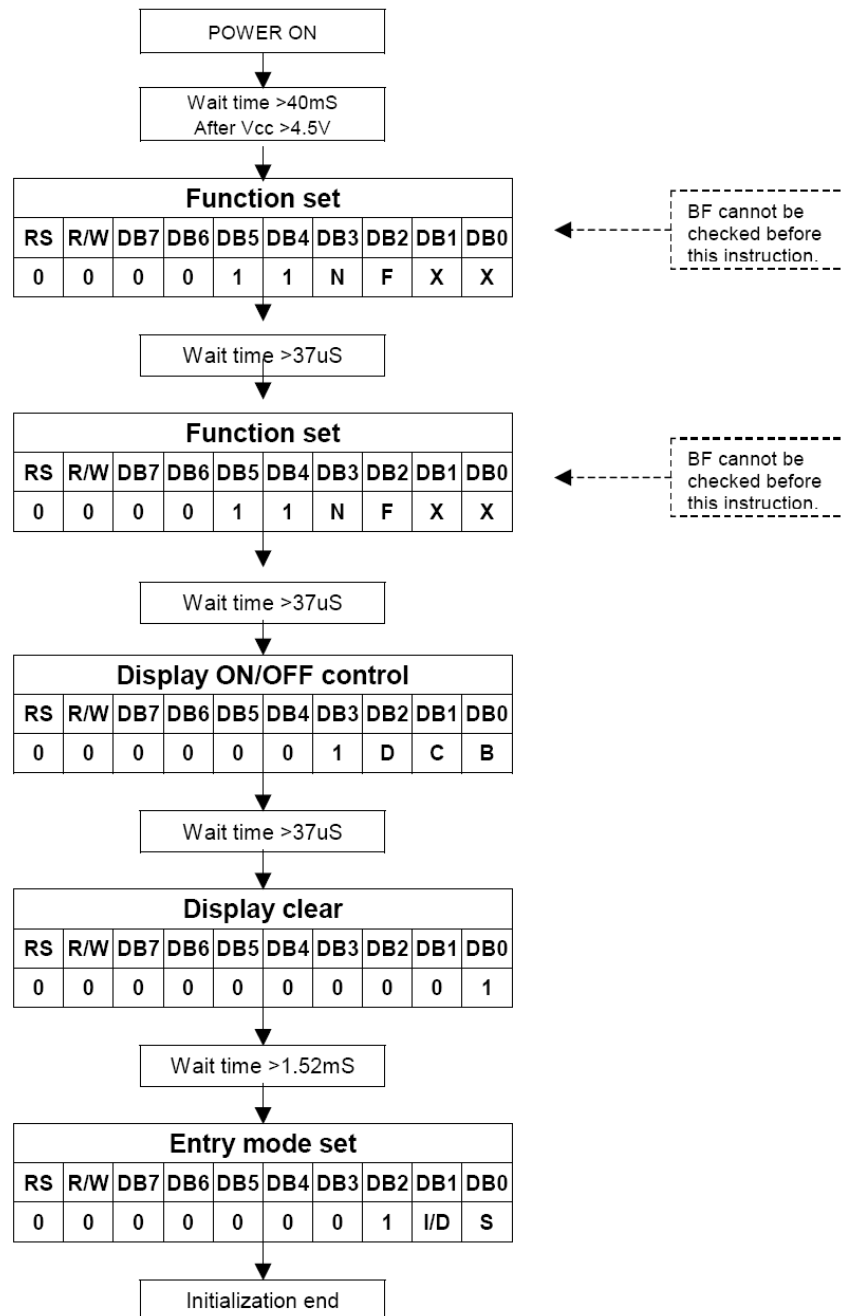

10 DD RAM ADDRESS

CHAR.	1	2	3	...	38	39	40
LINE 1	00	01	02	...	25	26	27
LINE 2	40	41	42	...	65	66	67
LINE 3	00	01	02	...	25	26	27
LINE 4	40	41	42	...	65	66	67

11 FONT TABLE

№. 7066-0T

b7-b4 b3-b0	0000	0001	0010	0011	0100	0101	0110	0111	1000	1001	1010	1011	1100	1101	1110	1111
0000	CG RAM (1)			0	1	2	3	4			5	6	7	8	9	0
0001	(2)	!	1	A	Q	a	q			Г	Я	W	.	U	5	
0010	(3)	"	2	B	R	b	r			Е	Б	Ь	U	Ш	6	
0011	(4)	#	3	C	S	c	s			К	Е	U	U	а	4	
0100	(5)	\$	4	D	T	d	t			Э	Г	Ь	7	6	В	
0101	(6)	%	5	E	U	e	u			Н	Е	О	Х	U	7	
0110	(7)	&	6	F	V	f	v			Н	Н	Ю	7	U	8	
0111	(8)	'	7	G	W	g	w			Л	Э	Я	Г	'	Г	
1000	(1)	(8	H	X	h	x			П	М	О	U	'	8	
1001	(2))	9	I	Y	i	y			У	А	О	Г	'	9	
1010	(3)	*	:	J	Z	j	z			Ф	К	U	↓	Е	9	
1011	(4)	+	;	K	L	k	l			Ч	а	"	W	С	8	
1100	(5)	,	<	L	Ф	l	ф			Ш	Н	%	W	0	9	
1101	(6)	-	=	M	I	m	i			б	Н	С	W	*	8	
1110	(7)	.	>	N	^	n	^			В	н	7	7	o	9	
1111	(8)	/	?	O	_	o	_			Э	Г	Е	.	o	9	

12 QUALITY AND RELIABILITY

12.1 TEST CONDITIONS

Tests should be conducted under the following conditions :

Ambient temperature : $25 \pm 5^{\circ}\text{C}$

Humidity : $60 \pm 25\% \text{ RH}$.

12.2 SAMPLING PLAN

Sampling method shall be in accordance with MIL-STD-105E, inspection level II, normal inspection, and single sampling plan tables for normal, tightened, and reduced inspection.

12.3 ACCEPTABLE QUALITY LEVEL

A major defect is defined as one that could cause failure to or materially reduce the usability of the unit for its intended purpose. A minor defect is one that does not materially reduce the usability of the unit for its intended purpose or is an infringement from established standards and has no significant bearing on its effective use or operation.

12.4 APPEARANCE

An appearance test should be conducted by human sight at approximately 30 cm distance from the LCD module under fluorescent light. The inspection area of LCD panel shall be within the range of following limits.

12.5 INSPECTION QUALITY CRITERIA

ITEM	Description of defects			Class of defects	remark	
Function	No display		Reject	Major		
	Display abnormal		Reject	Major		
	Missing line		Reject	Major		
Black spots	Ave. dia. D		Area A	Area B	Minor	Two spots must be between about 5 mm
	$D \leq 0.13$		Disregard			
	$0.13 < D \leq 0.15$		2	2		
	$0.13 < D \leq 0.25$		1	2		
	$0.25 < D$		0	1		
Black line	Width W	Length L	Area A	Area B	Minor	
	≤ 3.0	≤ 0.02	Disregard			
	≤ 2.0	≤ 0.04	2	2		
	≤ 1.0	≤ 0.06	1	2		
		> 0.06	0	0		
Scratch	Width W		Length L	Accept	Minor	
	$W \leq 0.02$		-----	Disregard		
	$0.02 \leq W \leq 0.05$		$L \leq 3.0$	2		
	$W > 0.05$		-----	0		
Appearance	PCB copper circuit showed		Reject		Minor	
	PCB scratch was over 5 mm		Reject			
	Sort pad was damaged		Reject			
★ Back-Light	Function didn't work		Reject		Major	
	Some area didn't work		Reject			
	Bright was not even		Reject			
	B/L color was not correct		Reject			
★ T/P (DOTS)	$D \leq 0.2\text{mm}$		Reject		Major	
	$0.2\text{mm} < D \leq 0.3\text{mm}$		Reject			
	$0.3\text{mm} < D$		Reject			
★ T/P(Scratch)	$W \leq 0.02\text{mm}$		$10\text{mm} < L$	Disregard	Major	
	$0.05\text{mm} \leq W \leq 0.1\text{mm}$		$10\text{mm} < L$	1		
	$0.1\text{mm} \leq W$		$10\text{mm} < L$	0		
『★』 Symbol means LCM has this material.						

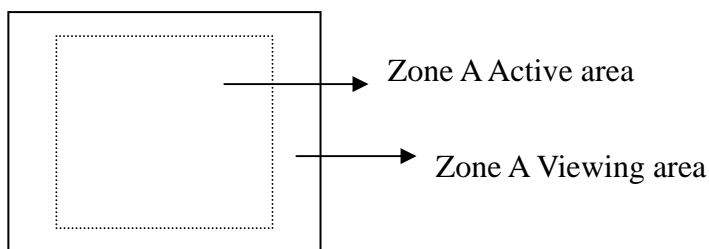

12.6 RELIABILITY

Test Item	Test Conditions	Note
	Extended Temp. type	
High Temperature Operation	70±3°C , t=96 hrs	
Low Temperature Operation	-20±3°C , t=96 hrs	
High Temperature Storage	80±3°C , t=96 hrs	1,2
Low Temperature Storage	-30±3°C , t=96 hrs	1,2
Thermal Shock Test	-30°C ~ 25°C ~ 80°C 30 m in. 5 min. 30 min. (1 cycle) Total 5 cycle	1,2
Humidity Test	40 °C, Humidity 90%, 96 hrs	1,2
Vibration Test (Packing)	Sweep frequency : 10 ~ 55 ~ 10 Hz/1min Amplitude : 0.75mm Test direction : X.Y.Z/3 axis Duration : 30min/each axis	2

Note 1 : Condensation of water is not permitted on the module.

Note 2 : The module should be inspected after 1 hour storage in normal conditions
(15-35°C , 45-65%RH).

Definitions of life end point :

- Current drain should be smaller than the specific value.
- Function of the module should be maintained.
- Appearance and display quality should not have degraded noticeably.
- Contrast ratio should be greater than 50% of the initial value.

13 HANDLING PRECAUTIONS

- (1) A LCD module is a fragile item and should not be subjected to strong mechanical shocks.
- (2) Avoid applying pressure to the module surface. This will distort the glass and cause a change in color.
- (3) Under no circumstances should the position of the bezel tabs or their shape be modified.
- (4) Do not modify the display PCB in either shape or positioning of components.
- (5) Do not modify or move location of the zebra or heat seal connectors.
- (6) The device should only be soldered to during interfacing. Modification to other areas of the board should not be carried out.
- (7) In the event of LCD breakage and resultant leakage of fluid do not inhale, ingest or make contact with the skin. If contact is made rinse immediately.
- (8) When cleaning the module use a soft damp cloth with a mild solvent, such as Isopropyl or Ethyl alcohol. The use of water, ketone or aromatic is not permitted.
- (9) Prior to initial power up input signals should not be applied.
- (10) Protect the module against static electricity and observe appropriate anti-static precautions.
- (11) AMIPRE will provide one year warrantee for all products and three months warrantee for all repairing products.

14 OUTLINE DIMENSION

