

Cartridges

E 1:1

C105 Cartridges with Standard life tip for iron NA

Galvanic treatment of **Standard life** tips offers outstanding thermal performance and long duration.

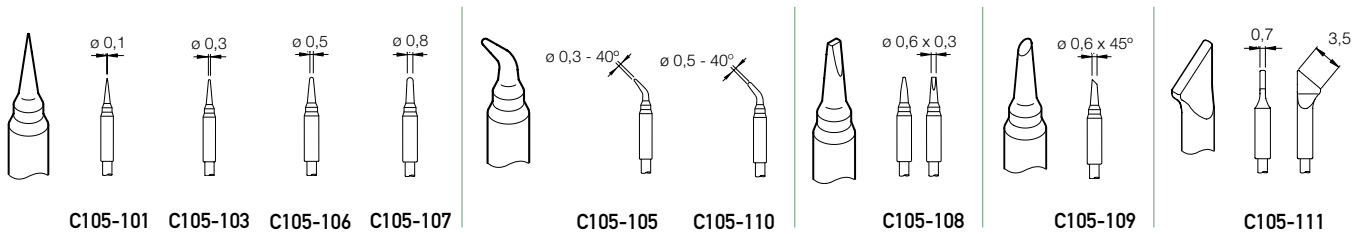

C210 Cartridges with Standard Life tips for T210 handpiece

Galvanic treatment of **Standard life** tips offers outstanding thermal performance and long duration.

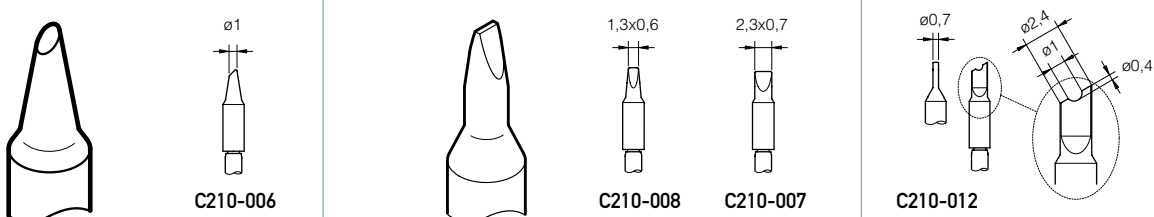
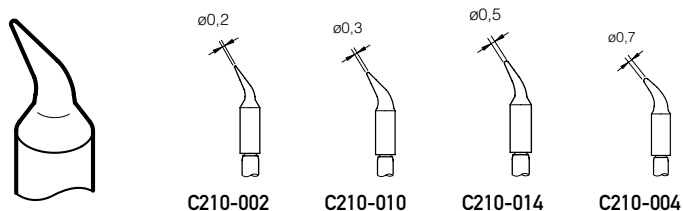
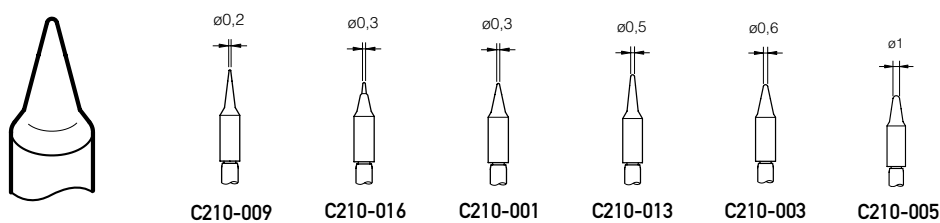
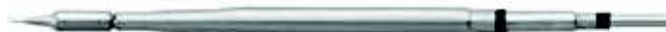

E 1:1

Cartridges

E 1:1

C120 Cartridges with **Standard Life** tips for microtweezers PA handpiece

Galvanic treatment of **Standard life** tips offers outstanding thermal performance and long duration.



CHIPS COMPONENTS

C120-002

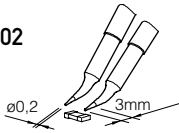

C120-006

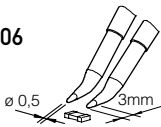

C120-004

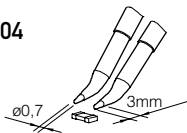

DUAL IN LINE

C120-001

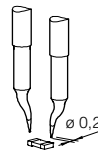

C120-003

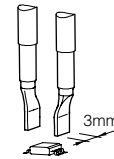

C120-005

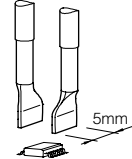

C120-007

C120-008

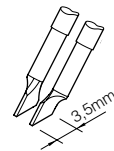

C120-009

C120-010

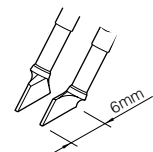

C120 Cartridges with **Extended Life** tips for microtweezers PA handpiece

Reinforced galvanic treatment of these tips offer longer duration especially for lead-free soldering applications.

CHIPS COMPONENTS

C120-902

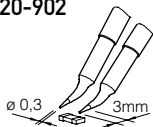

C120-906

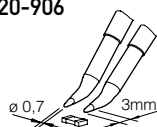

Supplied individually

E 1:1

Cartridges

E 1:1

C245 Cartridges with Standard Life tips for T245 handpiece

Galvanic treatment of **Standard life** tips offers outstanding thermal performance and long duration.

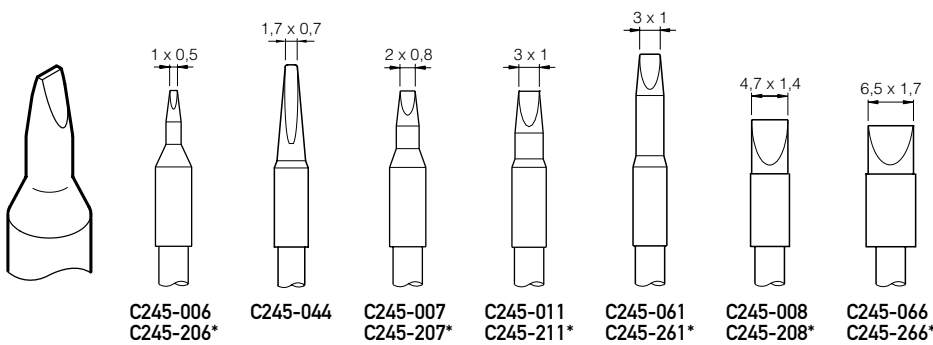
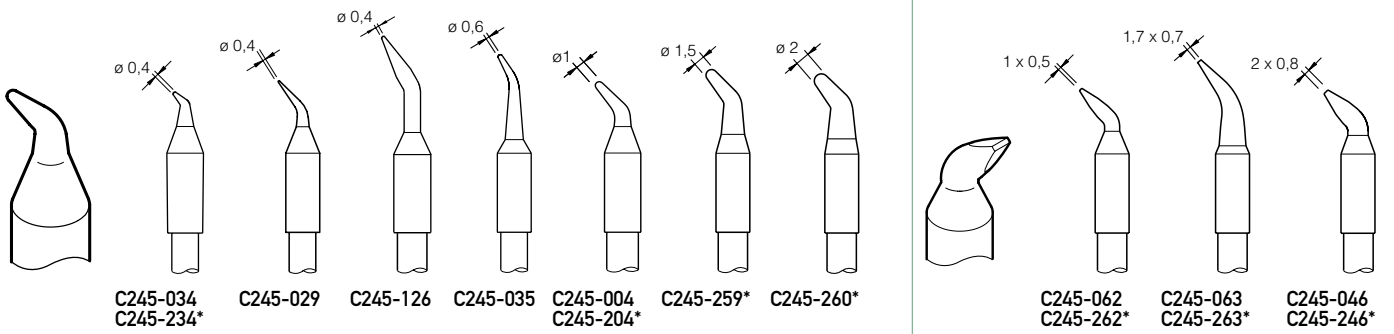
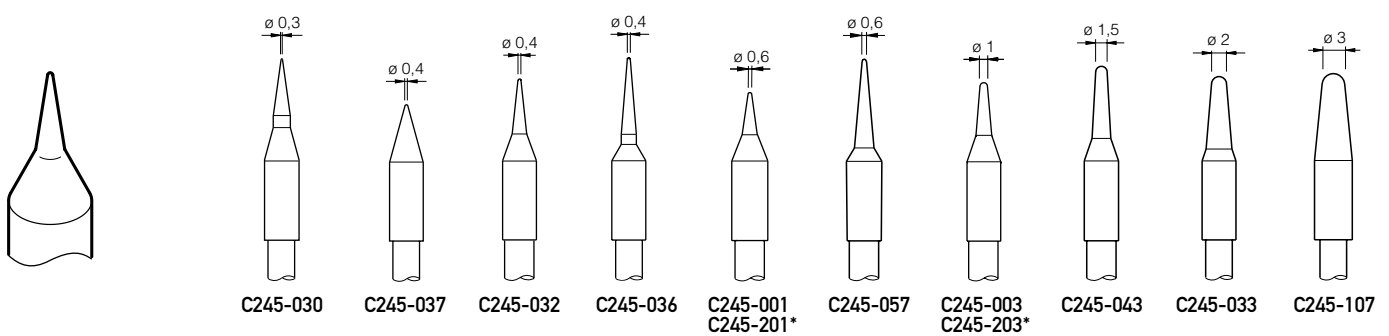

BLADE TYPE

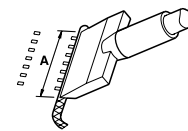

C245-014 A=10
 C245-013 A=21
 C245-049 A=32

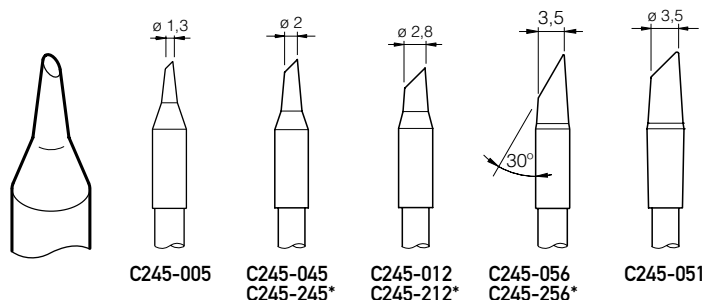

Hoof tip with reduced tinned surface, ideal for touch-up:

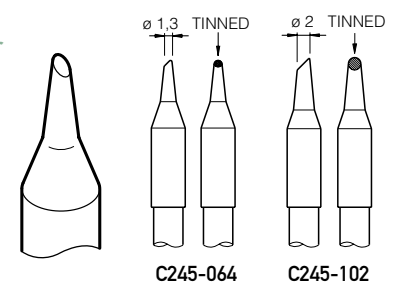

E 1:1

www.jbctools.com

*These cartridges are 20mm longer than normal cartridges for easy access to applications difficult to reach.

C245 Cartridges with Standard Life tips for T245 handpiece

E 1:1

Galvanic treatment of **Standard life** tips offers outstanding thermal performance and long duration.

MINI SPOON

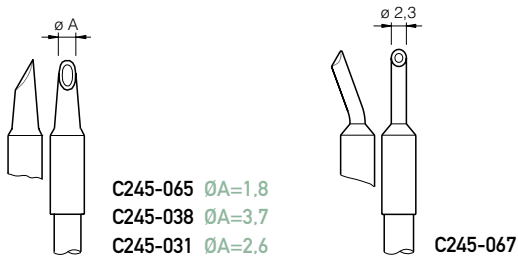

CHIP COMPONENTS

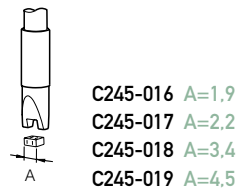

QFP Y PLCC

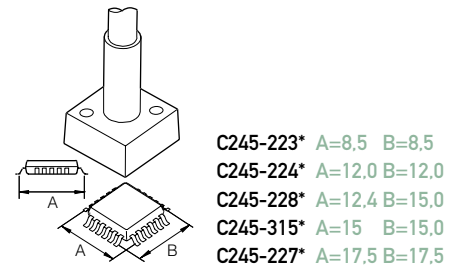

FOR PLCC SOCKETS

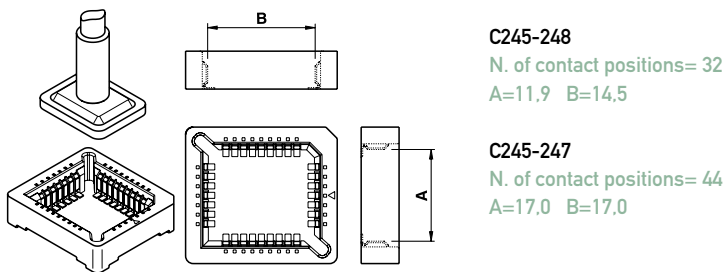

DUAL IN LINE

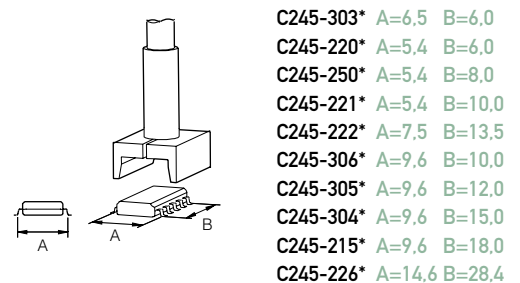

BEVEL EDGE TIPS

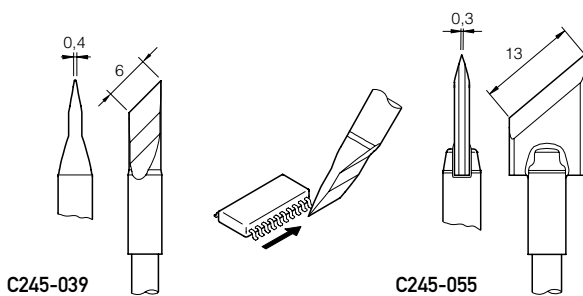

CARTRIDGES TO SOLDER SMT IC

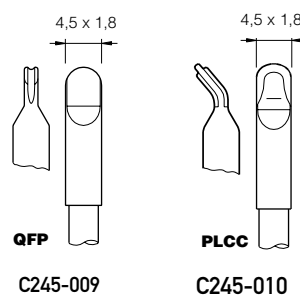

E 1:1

C245 Cartridges with Extended Life tips for T245 handpiece

E 1:1

Reinforced galvanic treatment of these tips offer longer duration especially for lead-free soldering applications.

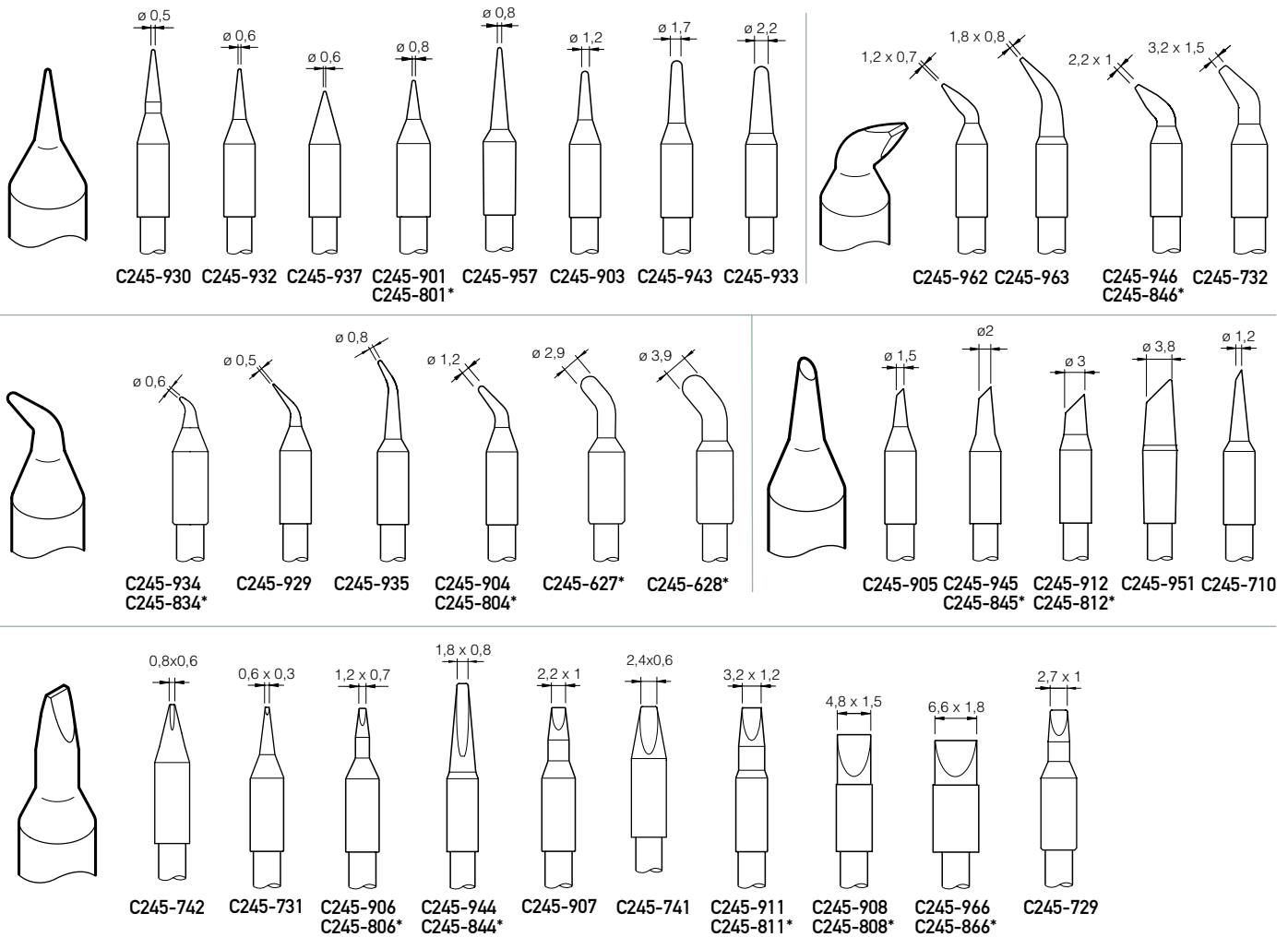

MINI SPOON

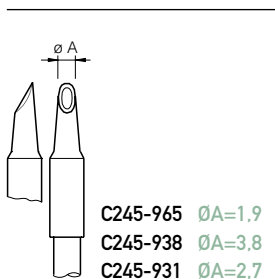

BLADE TYPE

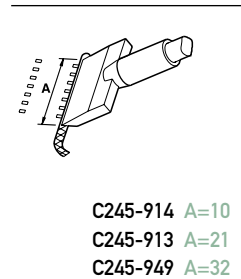

BEVEL EDGE TIPS

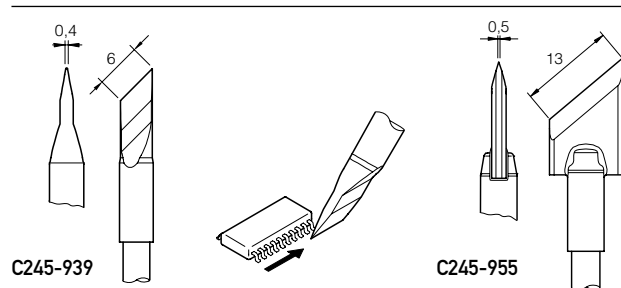

E 1:1

C130 Cartridges with **Extended life** tip for solder feed AP iron

Reinforced galvanic treatment of these tips offer longer duration especially for lead-free soldering applications.

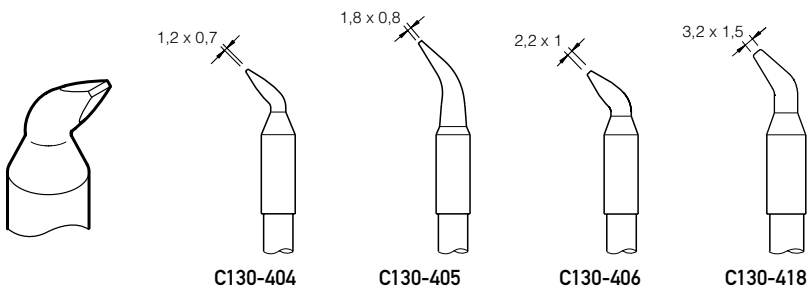
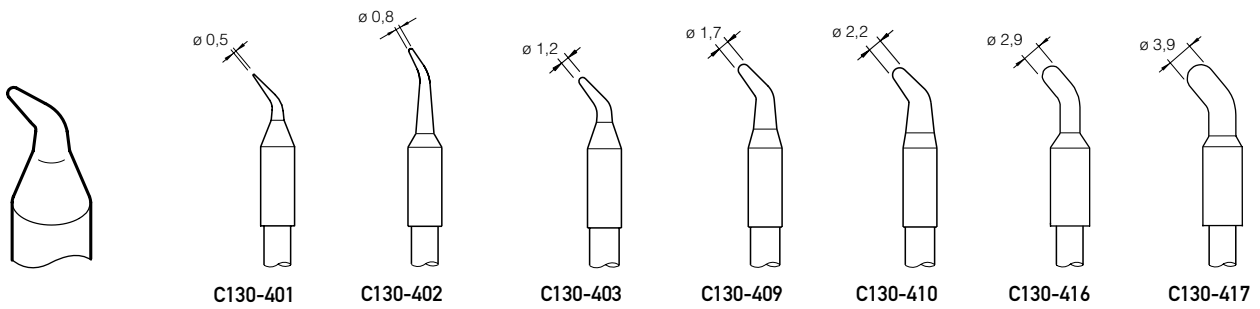

Cartridges

E 1:1

C250 Cartridges with Extended life tip for AL iron

Reinforced galvanic treatment of these tips offer longer duration especially for lead-free soldering applications.

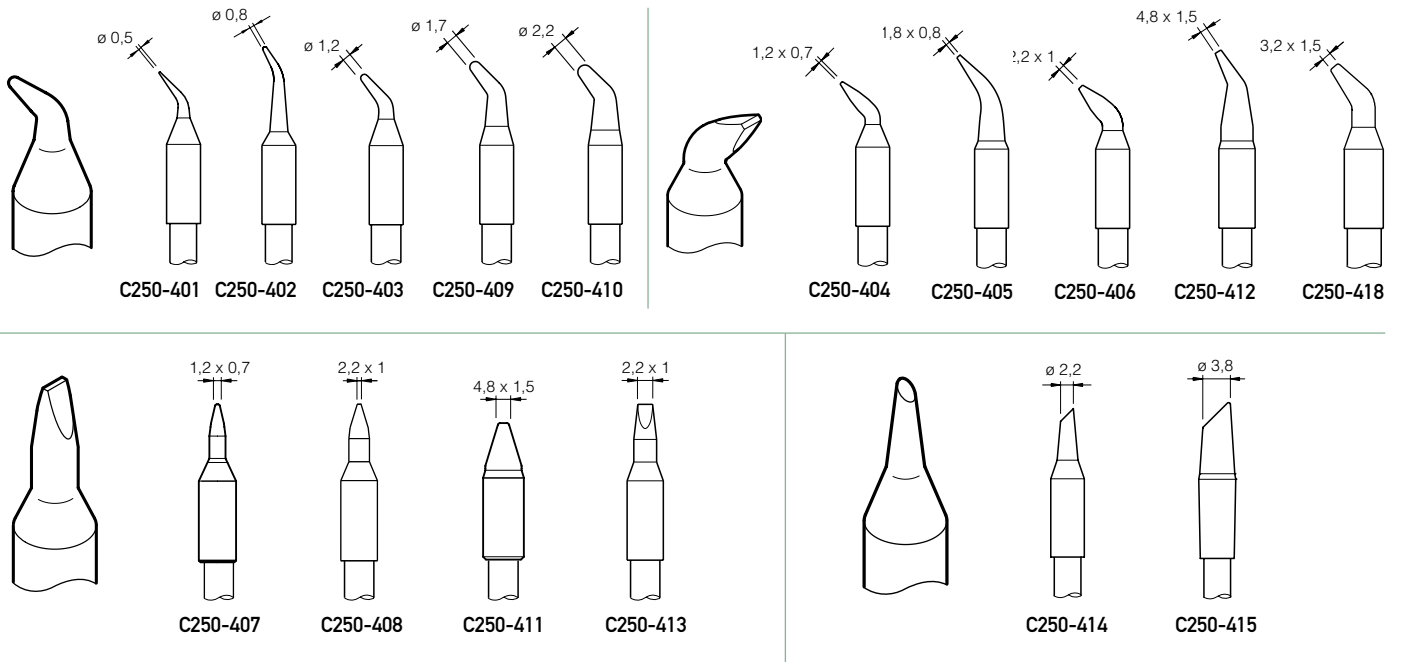

E 1:1

Cartridges

E 1:1

C420 Cartridges with Standard Life tips for HT tweezers

Galvanic treatment of Standard life tips offers outstanding thermal performance and long duration.



CHIPS COMPONENTS

C420-271 Amm=1,5

C420-272 Amm=2,6

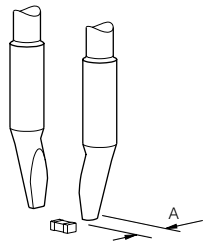

BLADE TYPE

C420-283 Amm=50

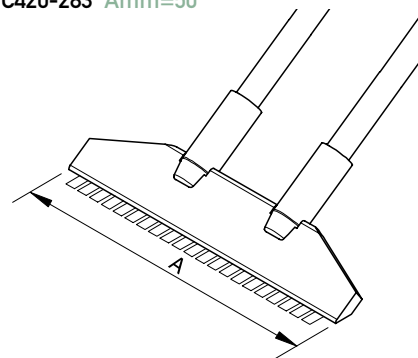

QFP Y PLCC

C420-279 Amm=8,0

C420-280 Amm=11,0

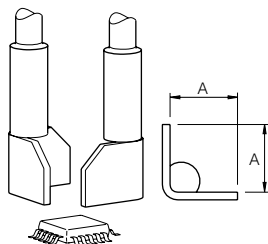

DUAL IN LINE

C420-273 Amm=4,0

C420-274 Amm=6,0

C420-275 Amm=8,0

C420-276 Amm=10,0

C420-277 Amm=15,0

C420-278 Amm=20,0

C420-285 Amm=22,0

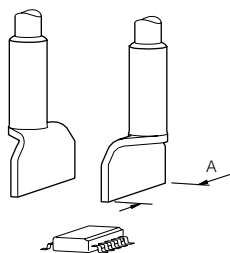

CABLE STRIPPER

C420-281 Amm=3,5 max.

C420-282 Amm=3,5 max.

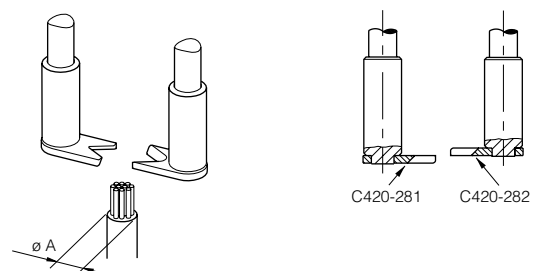

Supplied individually

E 1:1

C470 Cartridges **Extended life** for iron T245 with HD station

Galvanic treatment of these tips are reinforced with regards to the standard ones, providing a highest duration lasting, specially in lead free processes above all.

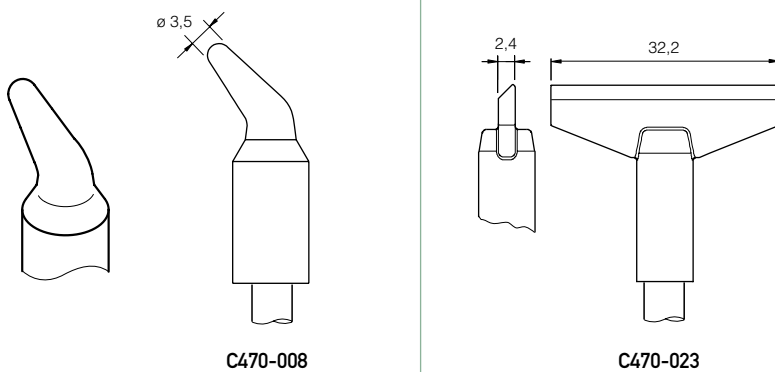
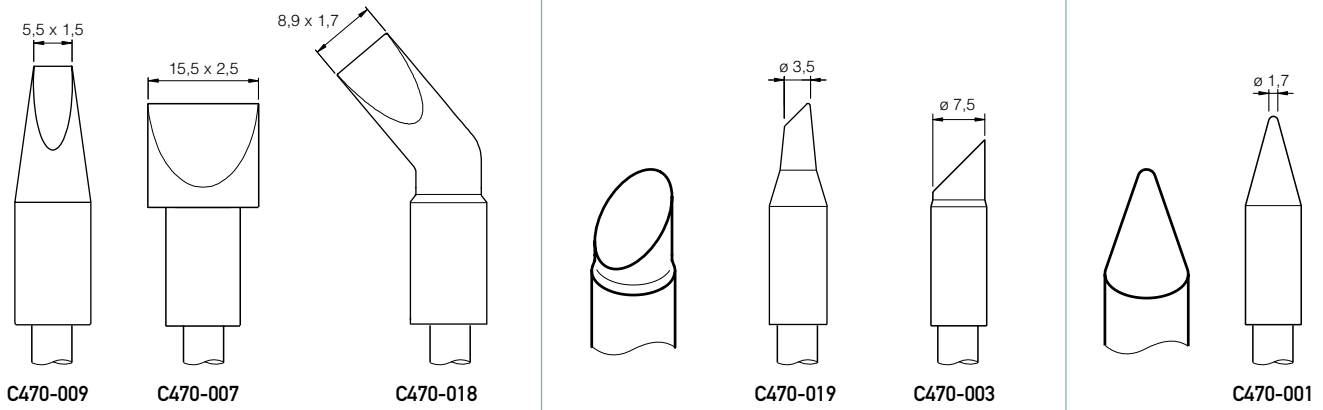
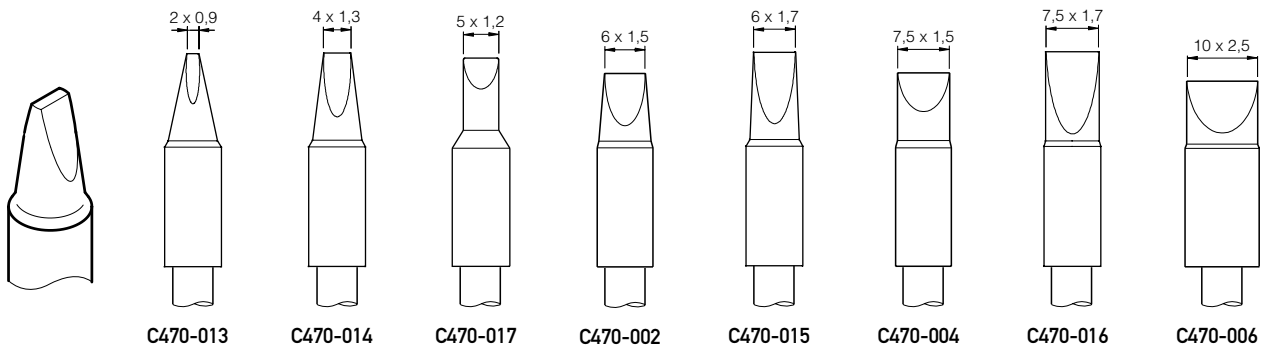

Desoldering tips

E 1:1

C360 Tips Standard Life for Microdesoldering DS iron

Galvanic treatment of **Standard life** tips offers outstanding thermal performance and long duration.

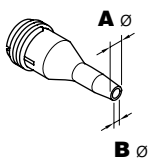

C360-001

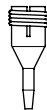

$\varnothing A=1$
 $\varnothing B=0,6$
 $\varnothing \text{max. pin}=0,4$

C360-002

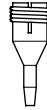

$\varnothing A=1,2$
 $\varnothing B=0,8$
 $\varnothing \text{max. pin}=0,6$

C360-003



$\varnothing A=1,4$
 $\varnothing B=1$
 $\varnothing \text{max. pin}=0,8$

C360-004



$\varnothing A=1,6$
 $\varnothing B=1,2$
 $\varnothing \text{max. pin}=1$

C560 Tips for Desoldering iron DR

C560 Standard Life Tips

Galvanic treatment of **Standard life** tips offers outstanding thermal performance and long duration.

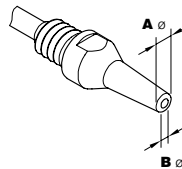

C560-001HT

$\varnothing A=1,4$ $\varnothing B=0,6$
 $\varnothing \text{max. pin}=0,4$

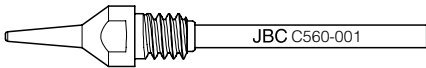

C560-002HT

$\varnothing A=1,8$ $\varnothing B=0,8$
 $\varnothing \text{max. pin}=0,6$

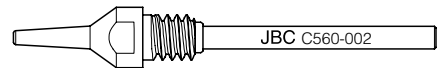

C560 Extended Life Tips

Galvanic treatment of these tips are reinforced with regards to the standard ones, providing a highest duration lasting, specially in lead free processes above all.

C560-003

$\varnothing A=2,7$ $\varnothing B=1$
 $\varnothing \text{max. pin}=0,8$

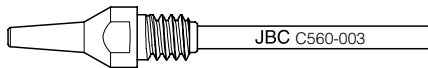

C560-007

$\varnothing A=4,8$ $\varnothing B=2,4$
 $\varnothing \text{max. pin}=2,2$

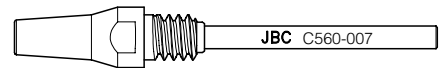

C560-004

$\varnothing A=3,2$ $\varnothing B=1,3$
 $\varnothing \text{max. pin}=1,1$

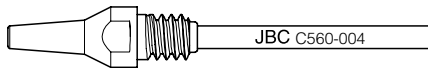

C560-015

$\varnothing A=5,2$ $\varnothing B=3$
 $\varnothing \text{max. pin}=2,8$

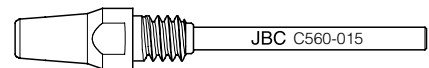

C560-005

$\varnothing A=3,4$ $\varnothing B=1,5$
 $\varnothing \text{max. pin}=1,3$

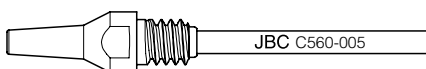

C560-009

$\varnothing A=5$ $\varnothing B=1,3$
 $\varnothing \text{max. pin}=1,1$

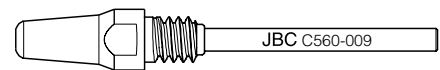

C560-006

$\varnothing A=4,2$ $\varnothing B=1,9$
 $\varnothing \text{max. pin}=1,7$

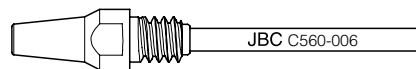

C560-014

$\varnothing A=2,5$ $\varnothing B=0,8$
 $\varnothing \text{max. pin}=0,6$

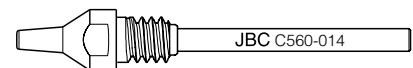

E 1:1

Desoldering tips

E 1:1

PAD CLEANING Standard pad cleaning tip for DR iron

The pad cleaning tips feature a distinctive contact surface slit which offers circulation of suction air for easy pad cleaning.

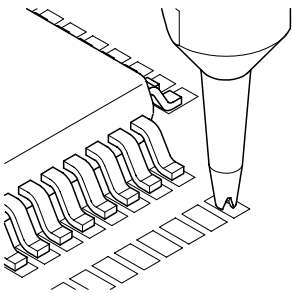

STANDARD PAD CLEANING TIP FOR DR

C560 Standard Life Tips

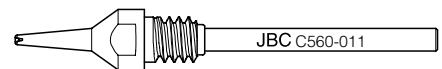
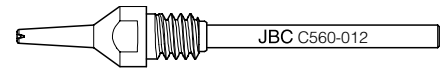
C560-011HT $\varnothing A=1,4$ $\varnothing B=0,6$ **C560-012HT** $\varnothing A=1,8$ $\varnothing B=0,8$ 

C560 Extended Life Tips

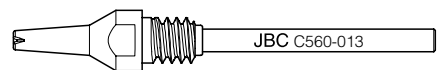
C560-013 $\varnothing A=2,7$ $\varnothing B=1$ 

E 1:1