



WARRANTY

ENGLISH

The JBC 2 years warranty, guarantees this equipment against all manufacturing defects, covering the replacement of defective parts and all necessary labour.

Warranty does not cover product wear due to use or mis-use.

In order for the warranty to be valid, equipment must be returned, postage paid, to the dealer where it was purchased enclosing this, fully filled in, sheet.

GARANTIA

ESPAÑOL

JBC garantiza este aparato durante 2 años, contra todo defecto de fabricación, cubriendo la reparación con sustitución de las piezas defectuosas e incluyendo la mano de obra necesaria.

Quedan excluidas de esta garantía las averías provocadas por mal uso del aparato y desgaste por uso.

Es indispensable para acogerse a esta garantía el envío del aparato al distribuidor donde se adquirió, a portes pagados, adjuntando esta hoja debidamente cumplimentada.

GARANTIE

FRANÇAIS

JBC garantit cet appareil 2 ans contre tout défaut de fabrication. Cela comprend la réparation, le remplacement des pièces défectueuses et la main d'oeuvre nécessaire.

La garantie ne couvre pas l'usure liée à l'utilisation et à la mauvaise utilisation du matériel.

Pour bénéficier de cette garantie il est indispensable d'envoyer l'appareil chez le distributeur où il a été acquis, en ports payés, en joignant cette fiche dûment remplie.

AD 2700

Control Unit 230V Ref. 2700200

Control Unit 120V Ref. 2700100

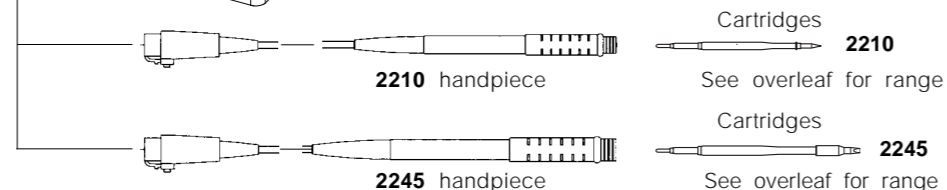
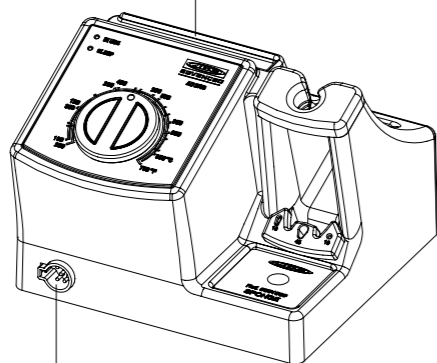

Structure of Advanced soldering stations system

The Advanced series has basic modules giving you full flexibility for choosing what you need for the work in hand, the modules being supplied separately.

Soldering stations: **AD 2200** and **AD 2700**.
Dual soldering station: **AD 4300** and **DD 5700**.
Digital soldering station: **DI 3000**.
Polystation: **DM 6700**.
Handpieces: **2210** and **2245**.
Cartridges: range of **2210** and **2245** cartridges.

Stands:
- **AD 8210** soldering iron stand Ref. 0788210 This stand has been especially designed for the **2210** handpiece.
- **AD 8245** soldering iron stand Ref. 0788245 This stand has been especially designed for the **2245** handpiece.

For a station to work properly, a control unit, a handpiece and one cartridge are needed. The soldering iron stands are necessary to connect the handpieces to the **AD 4300**, **DD 5700**, **DI 3000**, **DM 6700**, **DS 5300**, **AR 5800** and **AM 6500** stations.

HANDPIECES

- **2210** handpiece Ref. 2210000. Power: 20W. For high precision work, SMD, etc.
- **2245** handpiece Ref. 2245000. Power: 50W. For general soldering work.

One version of soldering iron handpiece covered with heat isolater is available:

- **2245** confort handpiece Ref. 2245110.

The **2210** and **2245** handpieces and cartridges comply with the MIL-SPEC-2000 referring to the potential difference between the soldering tip and ground connection, must be less than 2 mV.

The **2210** and **2245** handpieces can be connected to the following JBC stations: **AD 2200**, **AD 2700**, **AD 4300**, **DD 5700**, **DI 3000**, **DM 6700**, **DS 5300**, **AR 5800**, **AM 6500** and **MS 9000**.

Changing the handpiece's cartridge

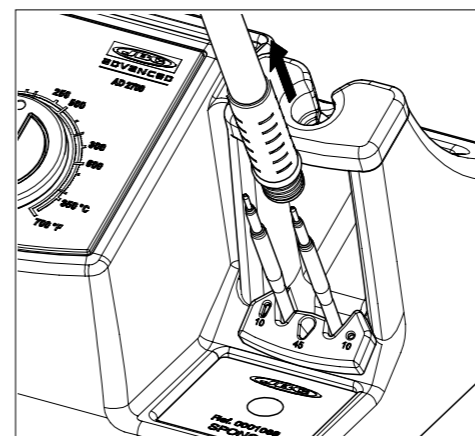

1 - Place the handpiece and remove the cartridge.

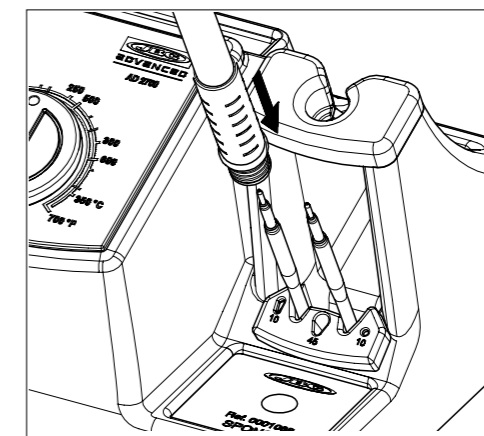

2 - Place the handpiece on top of the new cartridge, press it slightly down and remove the handpiece.

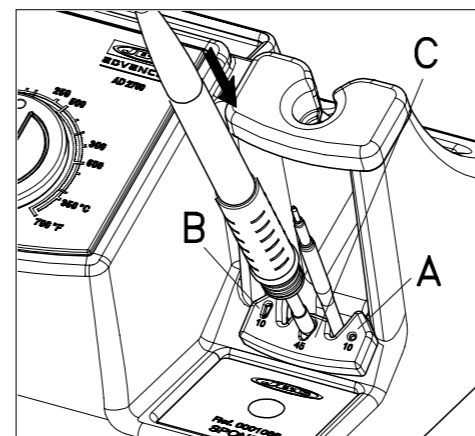

3 - Press the cartridge into the opening A, B or C:

- A. For straight 2210 cartridges.
- B. For curved 2210 cartridges.
- C. For 2245 cartridges.

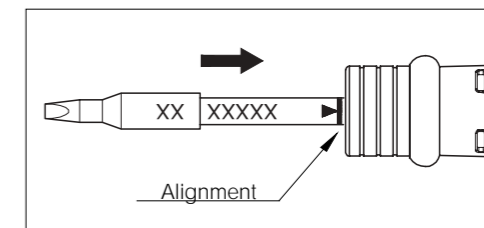

Important.

- It is essential to insert the cartridge till the end for a good connection. Take the mark ▶ as reference.

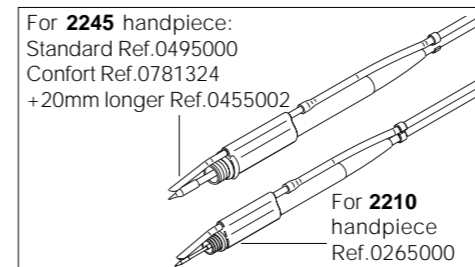

For **2245** handpiece:
Standard Ref.0495000
Confort Ref.0781324
+20mm longer Ref.0455002

For **2210** handpiece
Ref.0265000

Fume extractor accessories

Specially designed for the Advanced Series 2210 and 2245 handpieces. Easily clips onto the handpiece and can be quickly removed for easy maintenance.

0455430-0504

MANUFACTURED BY
JBC Industrias, S.A.
Ramón y Cajal, 3 - 08750 MOLINS DE REI
BARCELONA - SPAIN
Tel.: +34 93 325 32 00 - Fax: +34 93 680 49 70
http://www.jbctools.com e-mail:info@jbctools.com



SOLDERING HANDPIECES

2210
2245

CARTRIDGE RANGE

2245

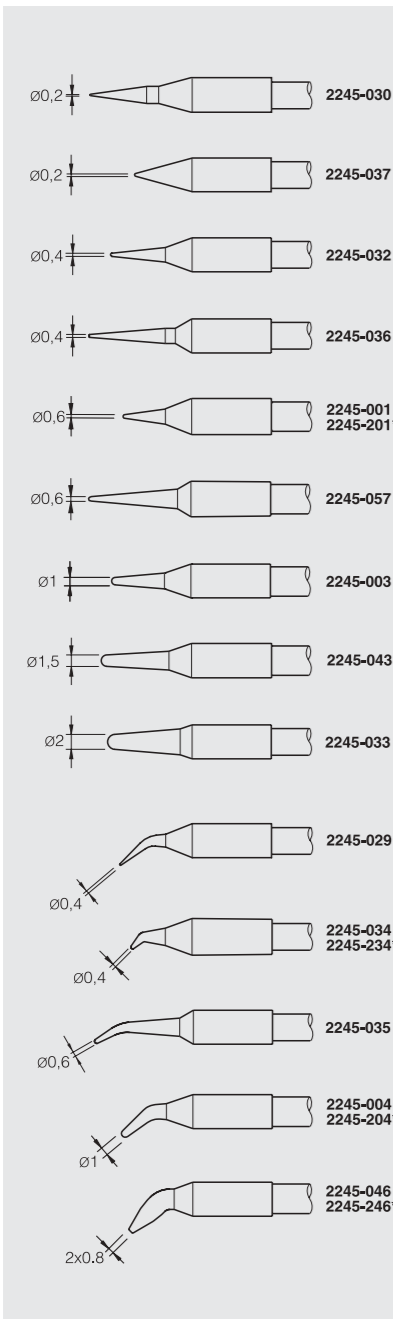
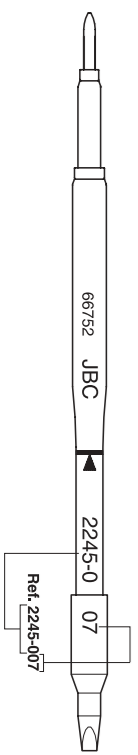

* These cartridges have a total length of 20mm longer than the normal cartridges, allowing them to reach places with difficult access and cartridges 2245-XXX are compatible with the AP 1300 solder feed iron.

All the cartridges shown are actual size.

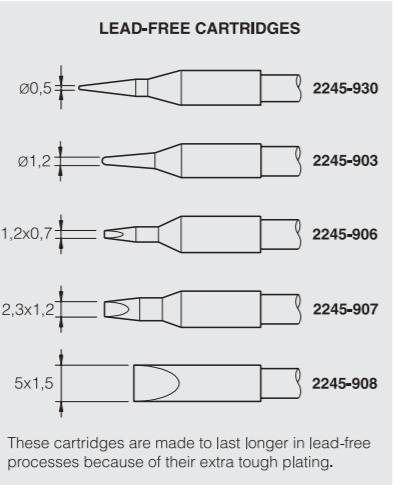
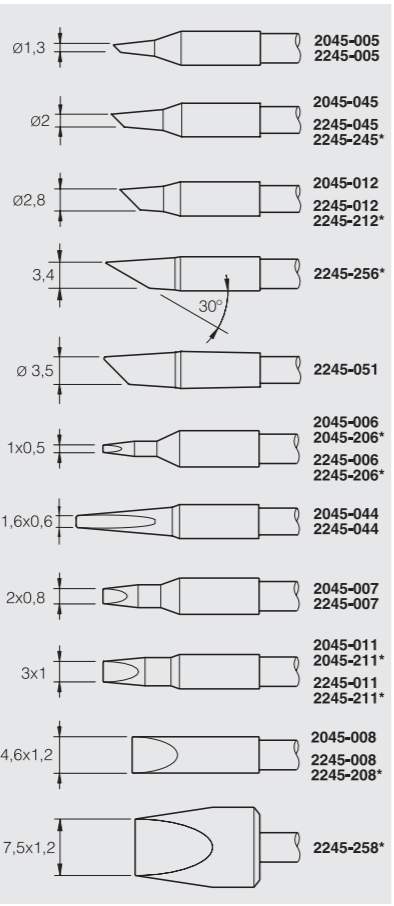

PATENT PENDING

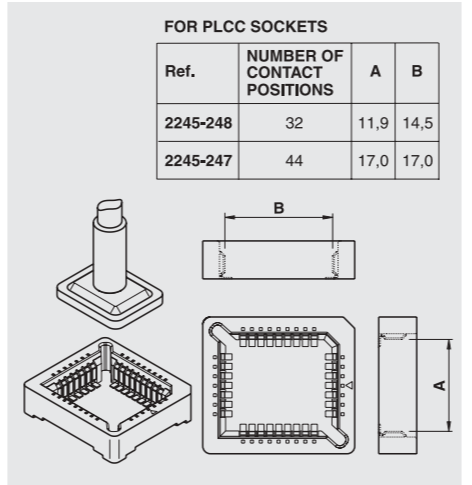
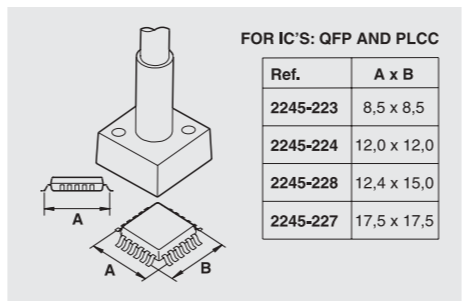
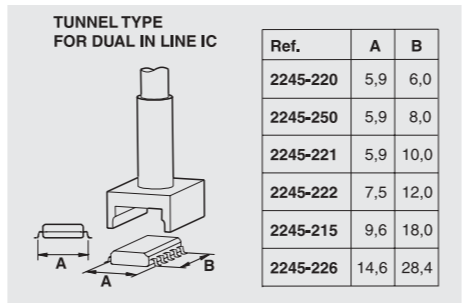
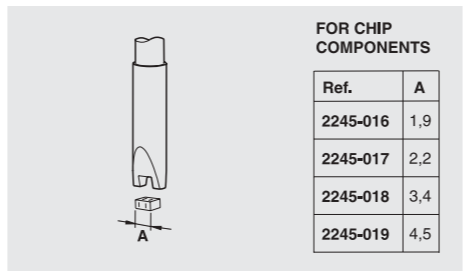
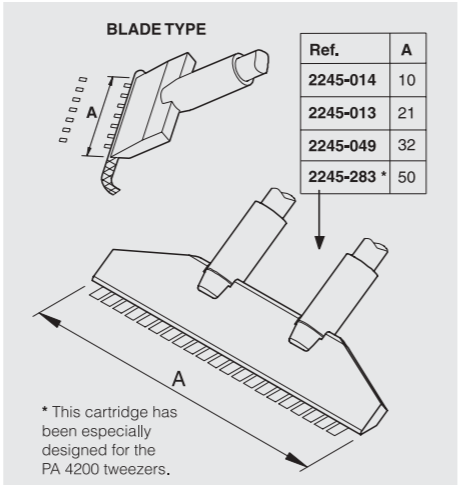
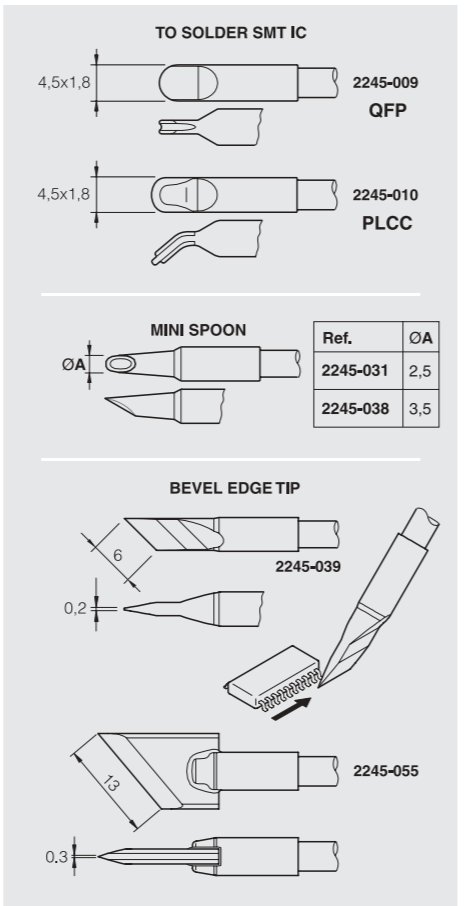

CARTRIDGE RANGE

2210

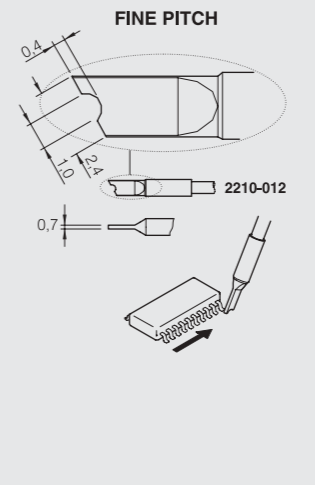
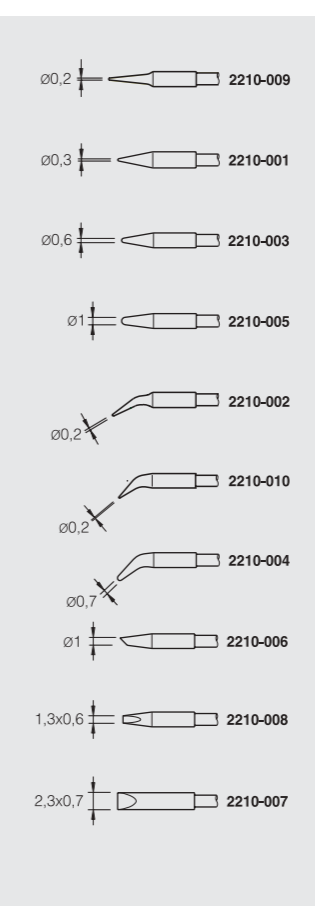
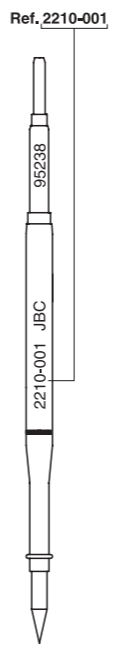

GARANTIE DEUTSCH

Für das vorliegende Gerät übernimmt JBC eine Garantie von 2 Jahren, für alle Fabrikationsfehler. Diese Garantie schliesst die Reparatur bzw. den Ersatz der defekten Teile sowie die entsprechenden Arbeitskosten ein.

Ausgeschlossen von dieser Garantieleistung sind durch unsachgemässen Gebrauch hervorgerufene Betriebsstörungen und normale Gebrauchsabnützungen.

Zur Inanspruchnahme dieser Garantie muss das Gerät portofrei an den Vertriebs Händler geschickt werden, bei dem es gekauft wurde. Fügen Sie dieses vollständig ausgefüllte Blatt bei.

GARANZIA ITALIANO

La JBC garantisce quest'apparato 2 anni contro ogni difetto di fabbricazione, e copre la riparazione e la sostituzione dei pezzi difettosi, includendo la mano d'opera necessaria.

Sono escluse da questa garanzia le avarie provocate da cattivo uso dell'apparato e logorio da utilizzo.

Per usufruire di questa garanzia, è indispensabile inviare, in porto franco, l'apparato al distributore presso il quale è stato acquistato, unitamente a questo foglio debitamente compilato.

SERIAL N°
STAMP OF DEALER SELLO DEL DISTRIBUIDOR CACHET DU DISTRIBUTEUR STEMPEL DES HÄNDLERS TIMBRO DEL DISTRIBUTORE
DATE OF PURCHASE FECHA DE COMPRA DATE D'ACHAT KAUF DATUM DATA DI ACQUISTO

