

1A Low Dropout Linear Regulator

❖ GENERAL DESCRIPTION

AX1007 is a low dropout positive adjustable or fixed-mode regulator with minimum of 1A output current capability. The product is specifically designed to provide well-regulated supply for low voltage IC applications such as high-speed bus termination and low current 3.3V logic supply. AX1007 is also well suited for other applications such as VGA cards. AX1007 is guaranteed to have lower than 1.4V dropout at full load current making it ideal to provide well-regulated outputs of 1.25 to 5.0 with $V_{OUT}+1.4V$ to 12V input supply VOLTAGE.

❖ FEATURES

- 1.4V maximum dropout at full load current
- Fast transient response
- Output current limiting
- Built-in thermal shutdown
- Good noise rejection
- MLCC Capacitors are available.
- 3-Terminal Adjustable or Fixed 1.2V, 1.5V, 1.8V, 2.5V, 3.3V, 5.0V
- Packages: SOT223, TO252 and SOT89.

❖ BLOCK DIAGRAM

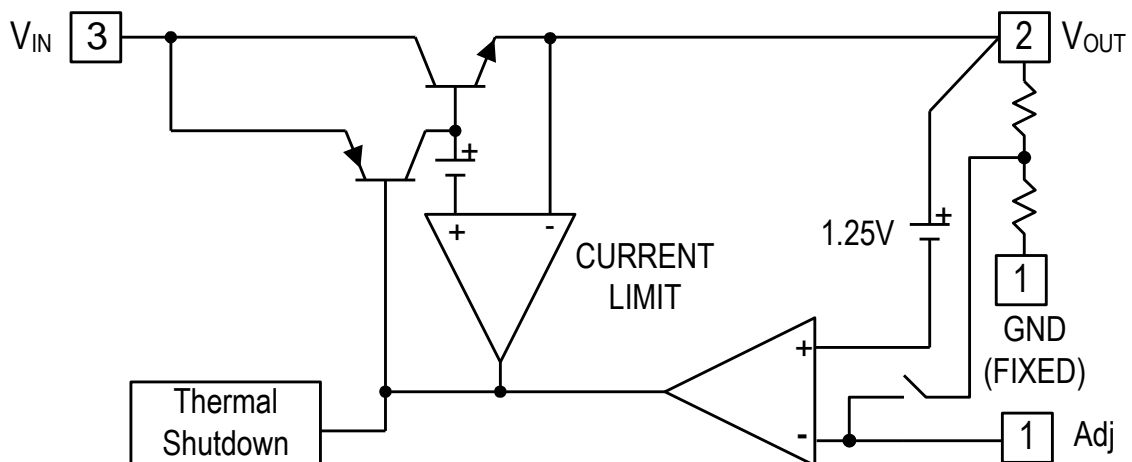

❖ PIN ASSIGNMENT

The packages of AX1007 are SOT223-3L, TO252-3L and SOT89-3L; the pin assignment is given by:

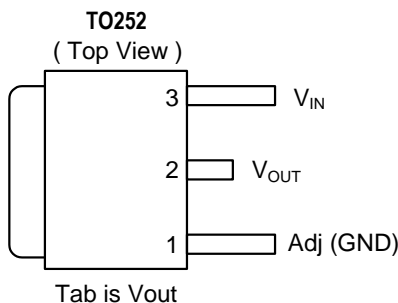
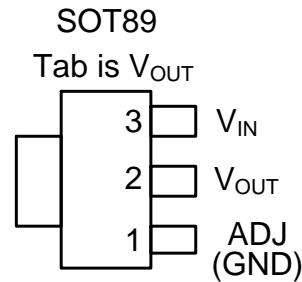
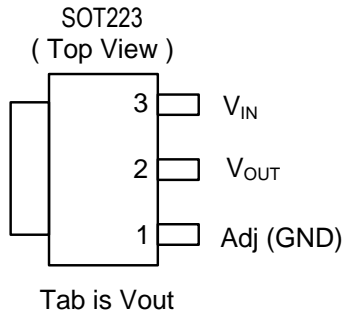

Name	Description
Adj (GND)	A resistor divider from this pin to the V _{OUT} pin and ground sets the output voltage. (Ground only for Fixed-Mode)
V _{OUT}	The output of the regulator. (Note1,2)
V _{IN}	The input pin of regulator. Typically a large storage capacitor is connected from this pin to ground to insure that the input voltage does not sag below the minimum dropout voltage during the load transient response. This pin must always be 1.5V higher than V _{OUT} in order for the device to regulate properly. (Note1)

Note1: To prevent oscillation, a 0.2uF minimum X7R or X5R dielectric is strongly recommended if ceramics are used as output capacitors.

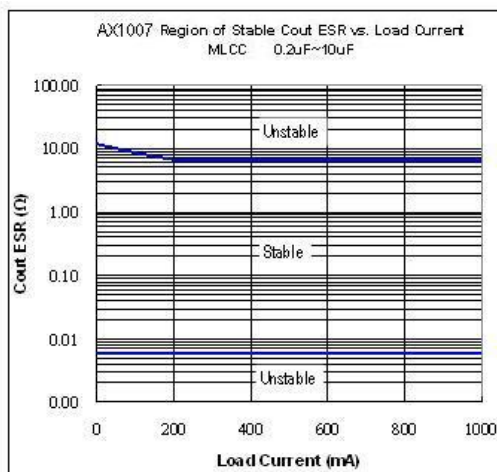

Note2: A minimum of 3.3uF EL capacitor to 100uF (10mΩ ≤ ESR ≤ 1Ω) must be connected from this pin to ground to insure stability.

❖ ORDER/MARKING INFORMATION

Order Information	Top Marking (SOT89-3L)
<p>AX1007 X XX X</p> <p>Package Vout Packing</p> <p>E : SOT223-3L Blank : ADJ Blank: Tube D : TO252-3L 12: 1.2V SOT223/TO252 : Tube F : SOT89-3L 15: 1.5V SOT89: Bag 18: 1.8V A : Taping 25: 2.5V 33: 3.3V 50: 5.0V</p>	<p>1 0 0 7 → Part number L Y W X → ID code: internal</p> <p>Output Type AX1007-ADJ: A → WW: 01~26(A~Z) 27~52(a~z) → Year: A=2010 1=2011 2=2012 ⋮ 9=2019</p>
Top Marking (SOT223-3L)	Top Marking (TO252-3L)
<p>ADJ</p> <p>Logo ← AX 1 0 0 7 → Part number Y W W X → ID code: internal → WW: 01~52 → Year: A=2010 1=2011 2=2012 ⋮ 9=2019</p> <p>FIX</p> <p>Output Voltage ← AX 1 0 0 7 - V V Y W W X → ID code: internal → WW: 01~52 → Year: A=2010 1=2011 2=2012 ⋮ 9=2019</p> <p>AX1007-12: 1.2V AX1007-15: 1.5V AX1007-18: 1.8V AX1007-25: 2.5V AX1007-33: 3.3V AX1007-50: 5.0V</p>	<p>ADJ</p> <p>Logo ← AX 1 0 0 7 → Part number Y Y W W X → ID code: internal → WW: 01~52 → Year: A=2010 1=2011 2=2012 ⋮ 9=2019</p> <p>FIX</p> <p>Output Voltage ← AX 1 0 0 7 - V V Y Y W W X → ID code: internal → WW: 01~52 → Year: A=2010 1=2011 2=2012 ⋮ 9=2019</p> <p>AX1007-12: 1.2V AX1007-15: 1.5V AX1007-18: 1.8V AX1007-25: 2.5V AX1007-33: 3.3V AX1007-50: 5.0V</p>

❖ ABSOLUTE MAXIMUM RATINGS

Characteristics	Symbol	Rating	Unit
DC Supply Voltage	V _{IN}	-0.3 to 15	V
Operating Junction Temperature Range	Top	-40 to +125	°C
Maximum junction Temperature	T _{MJ}	150	°C
Power Dissipation (Heat sink area 5mm*5mm.) T _A =25°C, T _J =125°C	SOT-223	1300	mW
	TO-252	2200	
	SOT89	620	
Power Dissipation (No heat sink ;No air flow) T _A =25°C, T _J =125°C	SOT-223	850	mW
	TO-252	1050	
	SOT89	330	
Storage Temperature	T _{ST}	-65 to 150	°C

❖ ELECTRICAL CHARACTERISTICS

 (T_A=25°C, Under Operating Conditions)

Characteristics	Conditions		Min	Typ	Max	Units
Operation Input Voltage			2.7	-	12	V
Reference Voltage	AX1007-ADJ	I _{OUT} = 10mA, T _J =25°C, (V _{IN-OUT})=1.5V	1.225	1.250	1.275	V
Output Voltage	AX1007-1.2	I _{OUT} =10mA, T _J = 25°C, 2.7V ≤ V _{IN} ≤ 12V	1.176	1.200	1.224	V
	AX1007-1.5	I _{OUT} = 10mA, T _J = 25°C, 3V ≤ V _{IN} ≤ 12V	1.470	1.500	1.530	V
	AX1007-1.8	I _{OUT} = 10mA, T _J = 25°C, 3.3V ≤ V _{IN} ≤ 12V	1.764	1.800	1.836	V
	AX1007-2.5	I _{OUT} = 10mA, T _J = 25°C, 4V ≤ V _{IN} ≤ 12V	2.450	2.500	2.550	V
	AX1007-3.3	I _{OUT} = 10mA, T _J = 25°C, 4.8V ≤ V _{IN} ≤ 12V	3.235	3.300	3.365	V
	AX1007-5.0	I _{OUT} = 10mA, T _J = 25°C, 6.5V ≤ V _{IN} ≤ 12V	4.900	5.000	5.100	V
Line Regulation	AX1007-XXX	I _{OUT} = 10mA, V _{OUT} +1.5V < V _{IN} <12V, T _J =25°C (Note 1,2)	-	0.2	0.5	%
Load Regulation	AX1007-ADJ	V _{IN} =2.7V, 10mA ≤ I _{OUT} ≤ 1A, T _J =25°C (Note 1,2)	-	0.4	1	%
	AX1007-1.2	V _{IN} =2.7V, 10mA ≤ I _{OUT} ≤ 1A,, T _J =25°C (Note 1,2)	-	10	12	mV
	AX1007-1.5	V _{IN} =3V, 10mA ≤ I _{OUT} ≤ 1A,, T _J =25°C (Note 1,2)	-	12	15	mV
	AX1007-1.8	V _{IN} =3.3V, 0mA ≤ I _{OUT} ≤ 1A, T _J =25°C (Note 1,2)	-	15	18	mV
	AX1007-2.5	V _{IN} =4V, 10mA ≤ I _{OUT} ≤ 1A, T _J =25°C (Note 1,2)	-	20	25	mV

	AX1007-3.3	$V_{IN}=5V, 10mA \leq I_{OUT} \leq 1A, T_J=25^\circ C$ (Note 1,2)	-	26	33	mV
	AX1007-5.0	$V_{IN}=6.5V, 10mA \leq I_{OUT} \leq 1A, T_J=25^\circ C$ (Note 1,2)	-	40	50	mV
Dropout Voltage ($V_{IN}-V_{OUT}$)	AX1007-ADJ /1.2/1.5/1.8 /2.5/3.3/5.0	$I_{OUT} = 1A,$ $\Delta V_{OUT}=1\%V_{OUT}$	-	1.2	1.4	V
Current Limit	AX1007-ADJ/1.5/ 1.8/2.5/3.3/5.0	$(V_{IN}-V_{OUT}) = 1.5V$	1.0	-	-	A
Minimum Load Current	AX1007-XXX	$0^\circ C \leq T_J \leq 125^\circ C$	-	5	7	mA
Adjust pin current	AX1007-ADJ	$(V_{IN}-V_{OUT}) = 1.5V,$ $I_{OUT}=10mA$	-	50	100	uA
Ripple Rejection	F=120Hz, $C_{OUT}=10\mu f, 0.2\mu f$ AX1007-XX, $(V_{IN}-V_{OUT}) = 1.5V$		50	60	70	dB
Temperature Stability	$I_{OUT}=10mA$		-	0.5	-	%
Thermal shutdown Temp (Over temperature protect)			-	145	-	$^\circ C$
Thermal Shutdown Hysteresis			-	40	-	$^\circ C$
θ_{JA} Thermal Resistance Junction-to-Ambient (Note4)	SOT-223	-	75	-	-	$^\circ C/W$
	TO-252	-	45	-	-	
	SOT89	-	160	-	-	
Thermal Resistance Junction-to-Ambient (No heat sink ;No air flow)	SOT-223	-	117	-	-	$^\circ C/W$
	TO-252	-	92	-	-	
	SOT89	-	300	-	-	
θ_{JC} Thermal Resistance Junction-to-Case	SOT-223	-	15	-	-	$^\circ C/W$
	TO-252	-	10	-	-	
	SOT89	-	100	-	-	

Note1: See thermal regulation specifications for changes in output voltage due to heating effects. Line and load regulation are measured at a constant junction temperature by low duty cycle pulse testing. Load regulation is measured at the output lead = 1/18" from the package.

Note2: Line and load regulation are guaranteed up to the maximum power dissipation of 6W. Power dissipation is determined by the difference between input and output differential and the output current. Guaranteed maximum power dissipation will not be available over the full input/output range.

Note3: Quiescent current is defined as the minimum output current required in maintaining regulation. At 12V input/output differential the device is guaranteed to regulate if the output current is greater than 10mA.

Note4: Tab is connected to the multi-layer PCB copper area 5mm*5mm.

❖ APPLICATION CIRCUIT

(1) Using Multilayer Ceramic Capacitor (MLCC)

Fixed Output

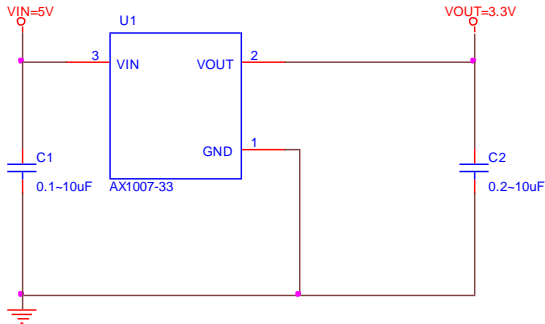

ADJ Output

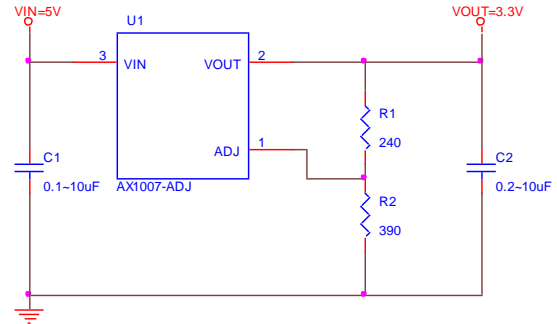

$$V_{OUT} = V_{REF} \times \left(1 + \frac{R2}{R1}\right); V_{REF} = 1.250V$$

(2) Using Aluminum Electrolytic Capacitor (AL)

Fixed Output

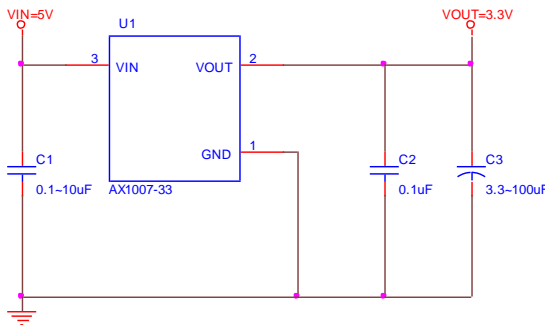

ADJ Output

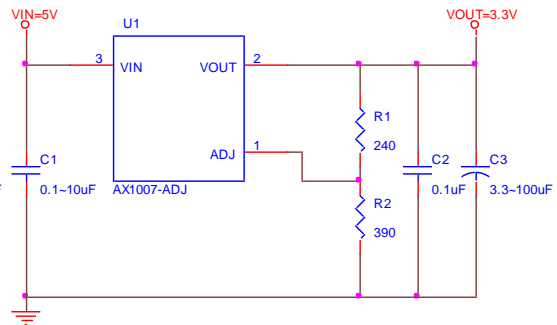

$$V_{OUT} = V_{REF} \times \left(1 + \frac{R2}{R1}\right); V_{REF} = 1.250V$$

❖ TYPICAL CHARACTERISTICS

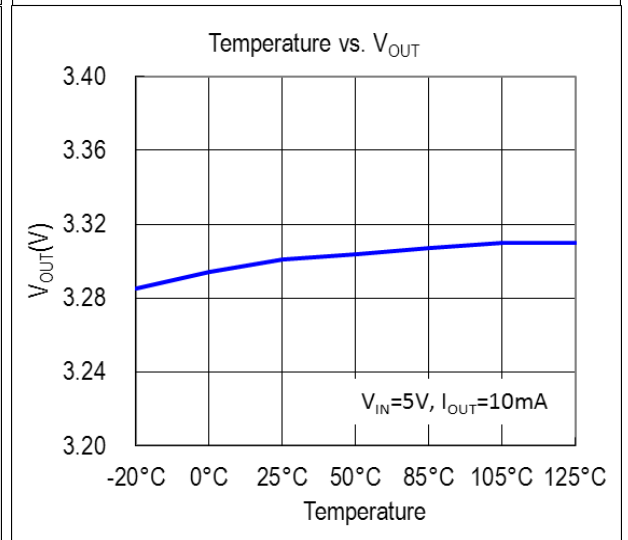
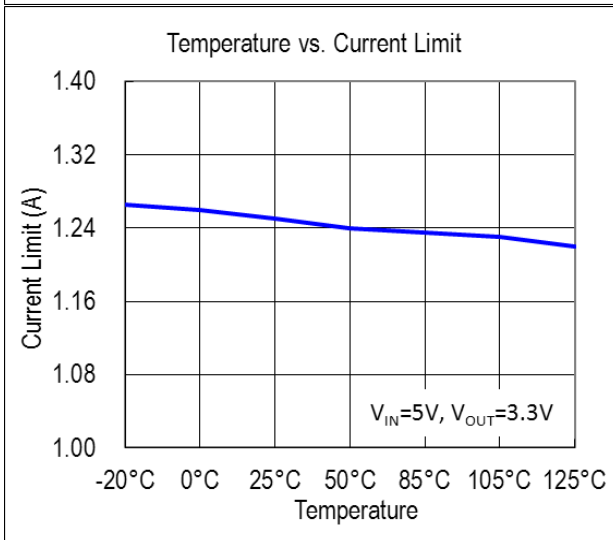
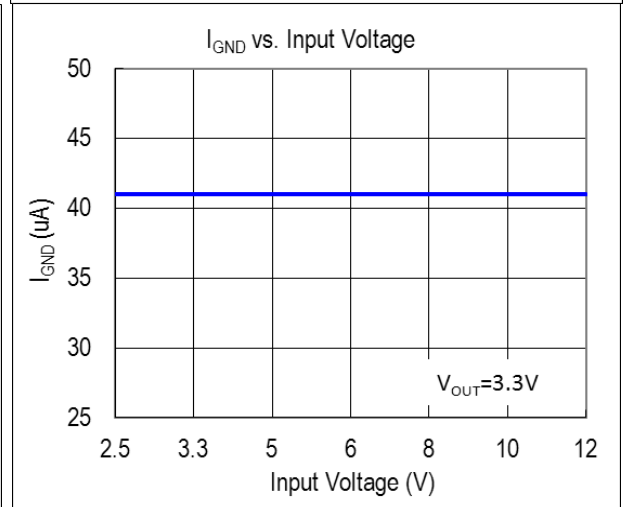
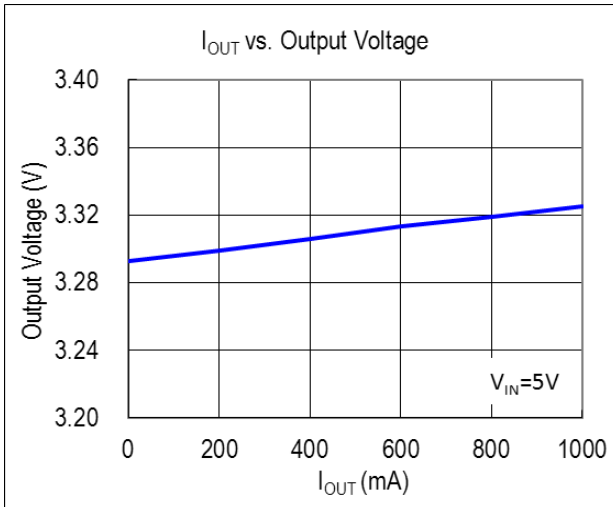
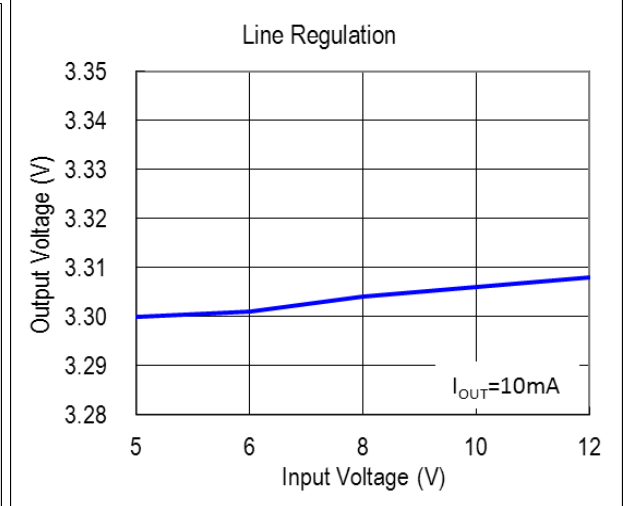
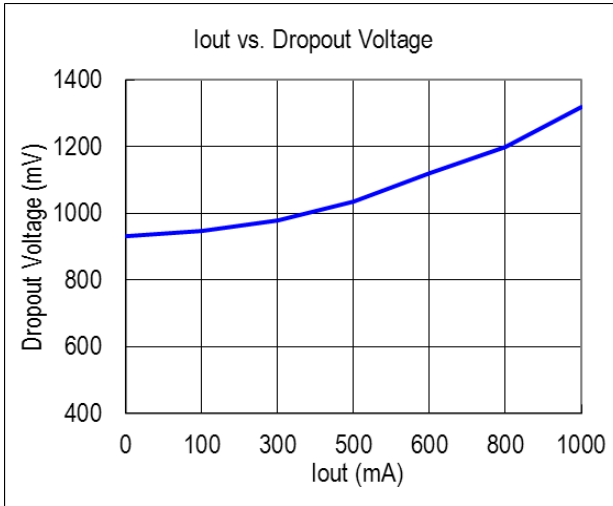

❖ TYPICAL CHARACTERISTICS (CONTINUOUS)

5→3.3V (I_{OUT}=300mA)

5→3.3V (I_{OUT}=1A)

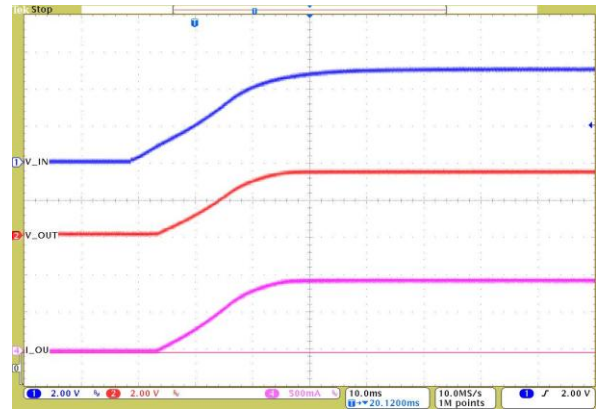
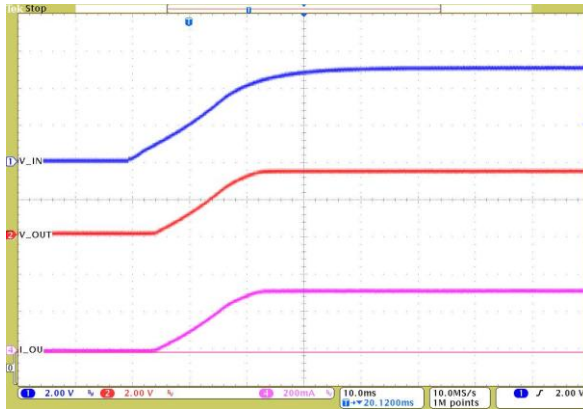

V_{IN}=5V, V_{OUT}=2.5V, I_{OUT}=0~600mA
C_{IN}=0.1u, C_{OUT}=0.2u MLCC

V_{IN}=5V, V_{OUT}=3.3V, I_{OUT}=100mA~1A,
C_{IN}=0.1u, C_{OUT}=0.2u MLCC

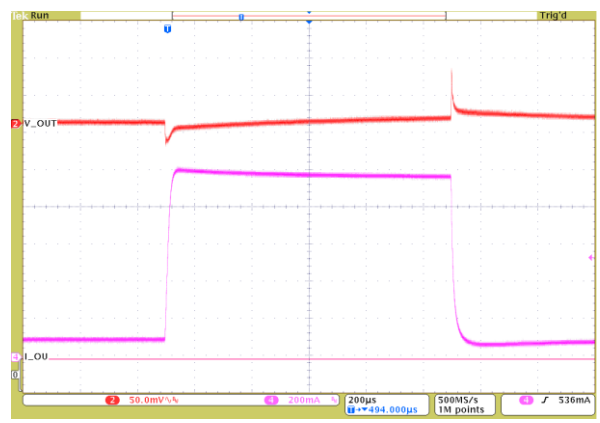
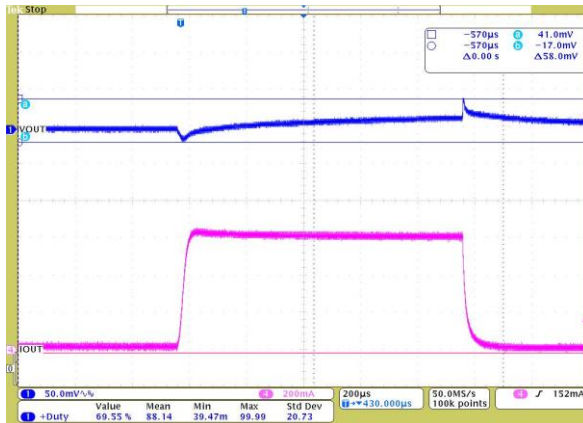

❖ PACKAGE OUTLINES

(1) SOT223-3L

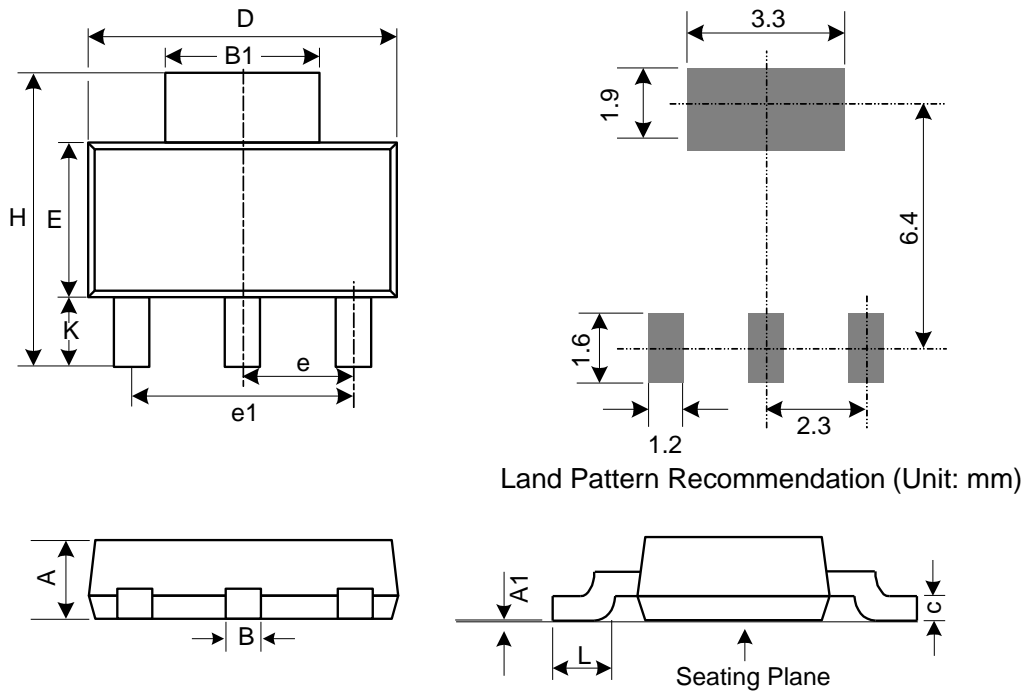

Symbol	Dimensions in Millimeters			Dimensions in Inches		
	Min.	Nom.	Max.	Min.	Nom.	Max.
A	-	-	1.8	-	-	0.071
A1	0.02	0.06	0.1	0.001	0.002	0.004
B	0.66	0.75	0.84	0.026	0.03	0.033
B1	2.9	3	3.1	0.114	0.118	0.122
C	0.23	0.315	0.35	0.009	0.012	0.014
D	6.3	6.5	6.7	0.248	0.256	0.264
E	3.3	3.5	3.7	0.13	0.138	0.146
H	6.7	7	7.3	0.264	0.278	0.287
L	0.75	-	-	0.03	-	-
K	1.5	1.75	2	0.059	0.069	0.079
e	2.3 Basic			0.091 Basic		
e1	4.6 Basic			0.181 Basic		

JEDEC outline: TO-261 AB

(2) T0252-3L

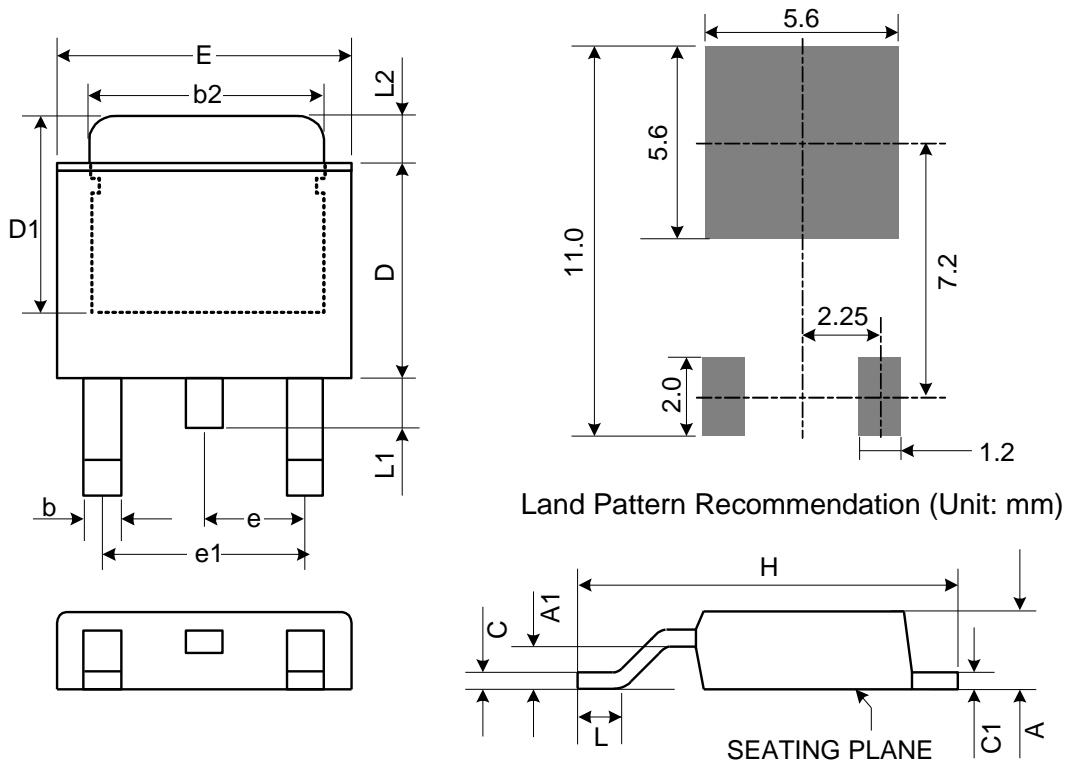

Symbol	Dimensions in Millimeters			Dimensions in Inches		
	Min.	Nom.	Max.	Min.	Nom.	Max.
A	2.18	2.29	2.39	0.086	0.09	0.094
A1	-	-	0.13	-	-	0.005
b	0.51	0.71	0.89	0.02	0.028	0.035
b2	4.95	5.21	5.46	0.195	0.205	0.215
C	0.46	0.53	0.61	0.018	0.021	0.024
C1	0.46	0.53	0.58	0.018	0.021	0.023
D	5.33	5.46	5.59	0.21	0.215	0.22
D1	4.57	-	-	0.18	-	-
E	6.35	6.55	6.73	0.25	0.258	0.265
e	2.29 BSC			0.090 BSC.		
e1	4.58 BSC			0.180 BSC.		
H	9.4	9.7	10.4	0.37	0.382	0.41
L	1.4	1.6	1.78	0.055	0.063	0.07
L1	-	-	1.02	-	-	0.04
L2	1.52	1.78	2.03	0.06	0.07	0.08

Mold flash shall not exceed 0.005inch per side
JEDEC outline: TO-252 AB

(3) SOT89-3L

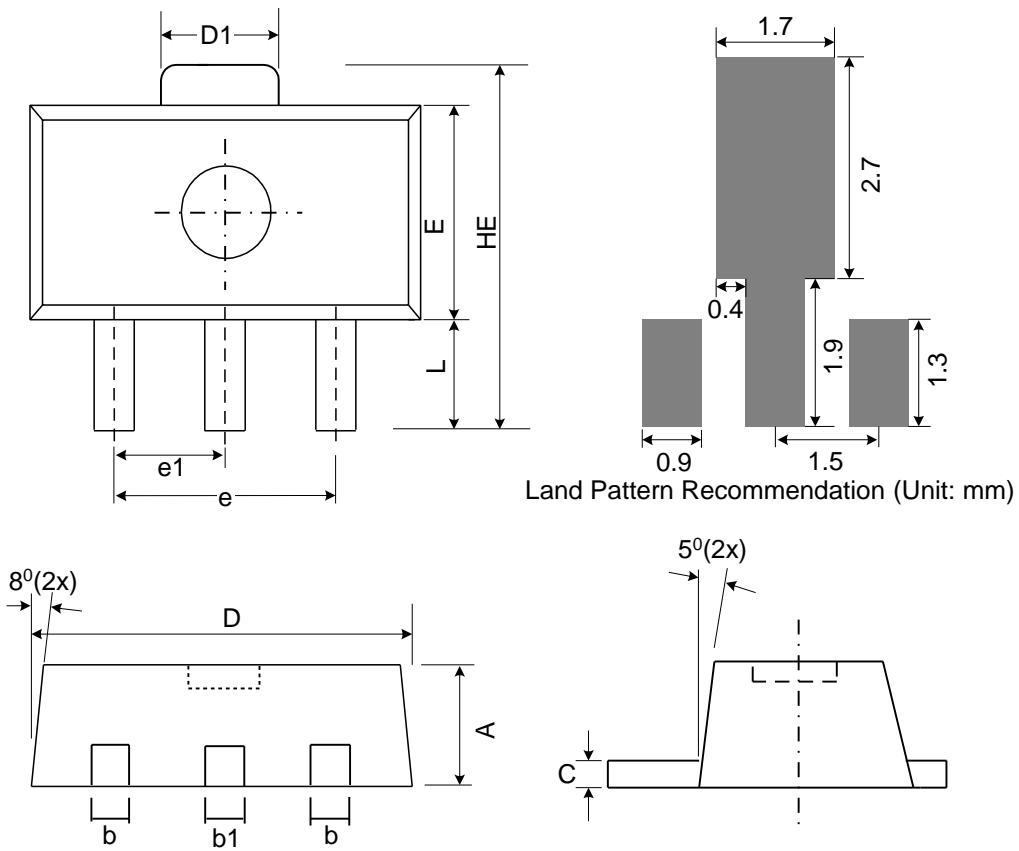

Symbol	Dimensions in Millimeters			Dimensions in Inches		
	Min.	Nom.	Max.	Min.	Nom.	Max.
A	1.40	1.50	1.60	0.055	0.059	0.063
b	0.36	0.42	0.48	0.014	0.017	0.019
b1	0.44	0.50	0.56	0.017	0.02	0.022
C	0.35	0.40	0.44	0.014	0.016	0.017
D	4.40	4.50	4.60	0.173	0.177	0.181
D1	1.35	1.59	1.83	0.053	0.063	0.072
e	3.0 BSC			0.118 BSC		
e1	1.5 BSC			0.059 BSC		
E	2.29	2.45	2.60	0.09	0.097	0.102
HE	3.94	4.10	4.25	0.155	0.161	0.167
L	0.80	1.00	1.20	0.031	0.04	0.047

JEDEC outline: TO-243 AB