

THIS DOCUMENT IS THE PROPERTY OF KEYSTONE ELECTRONICS CORP. AND SHALL NOT BE REPRODUCED, DISTRIBUTED OR USED AS A BASIS FOR MANUFACTURE WITHOUT PRIOR WRITTEN PERMISSION FROM KEYSTONE ELECTRONICS CORP.

ACTUAL SIZE

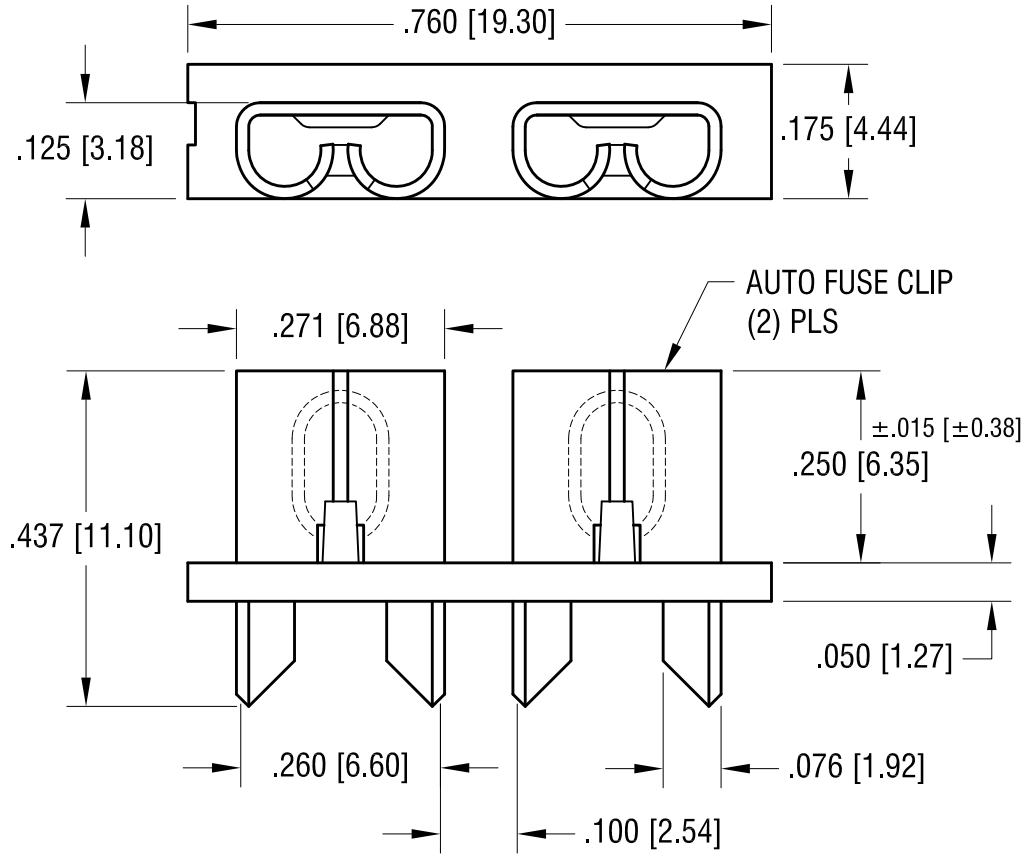
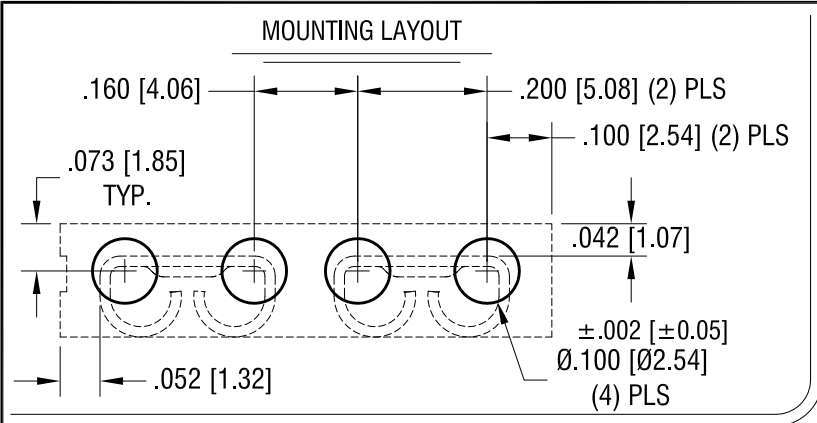
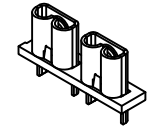

NOTE:  
 CLIP: .016 [0.40] TH'K BRASS, TIN NICKEL PLATE  
 BASE: MAT'L: NYLON 66/6, UL 94V-0  
 CURRENT RATING: 30 AMPS  
 VOLTAGE RATING: 500VAC  
 TEMPERATURE RATING: -58°F TO +292°F  
 (-50°C TO +145°C)

<b>KEYSTONE ELECTRONICS CORP.</b>			
www.keyelco.com • ASTORIA, N.Y. 11105-2017 • Tel (718) 956-8900			
PART NAME		PC AUTO FUSE SOCKET	
MATERIAL		AS NOTED	
FINISH		DRN BY	DATE
AS NOTED		BOONE	10.5.92
		APP'D	SCALE
		LN	4X
TOLERANCES	INCH [MM]	CODE	DWG NO.
DECIMAL	± .005 [± 0.15]	C	3522-2
ANGULAR	± 1°		
UNLESS OTHERWISE SPECIFIED			

8.18.15	CHANGE AS PER ECN15-079	G
3.0512	CHANGE AS PER ECN 12-029	F
8.18.06	CHANGE AS PER ECN 06-046	E
9.21.04	CHANGE AS PER ECN 04-121	D
DATE	DESCRIPTION	REV.