



全漢企業股份有限公司
FSP TECHNOLOGY INC.

台灣桃園市建國東路22號 統一編號：84239055
No. 22, Jianguo East Road., Taoyuan City, Taiwan, R.O.C.
TEL:+886-3-375-9888 Website : www.FSP-group.com
FAX:+886-3-375-6966 Email : sales@fsp-group.com.tw

SPECIFICATION



FSP060-1S35-48

Released Date:2013/07/25-18:12:50



全漢企業股份有限公司
FSP TECHNOLOGY INC.

台灣 桃園市建國東路 22 號
NO.22,jianguo E,Rd.,Taoyuan City, Taiwan,R.O.C.
TEL:+886-3-375-9888 FAX:+886-3-375-6966

SPECIFICATION

G.P,FSP060-1S35-48

| R&D | CHECK | APPROVED | REV. |
|-----|-------|----------|------|
| | | | 1 |

The spec. change list

| Item | Revision | Descriptions | Date |
|-------------|-----------------|------------------------------|------------------|
| 1 | 1 | Initial spec. release | 7/01'2008 |
| | | | |

1. SCOPE

The FSP060-1S35-48 is a 60 Watts single output, **full range input** switching power supply with POWER SAVING function, which could be use on many kinds of products .

2. MECHANICAL REQUIREMENTS

2.1 Power supply Dimension Constraints

127.0(L)*76.2(W)*25.0(H) (Height above the PCB) mm.

Note : Detail mechanic dimension please check the outline drawing .

2.2 Power Supply Connectors

Output Pin-Out

Pin assignment

| Pin number | Output Name | Wire Color | Wire AWG |
|------------|-------------|------------|----------|
| 1 | +48V | | |
| 2 | +48V | | |
| 3 | +48V | | |
| 4 | GND | | |
| 5 | GND | | |
| 6 | GND | | |

Note : connector spec. list below

Material: *Insulator: Nyion 66 UL94V-2
 *Contact: 1.14mm Tin Plated Square Pin

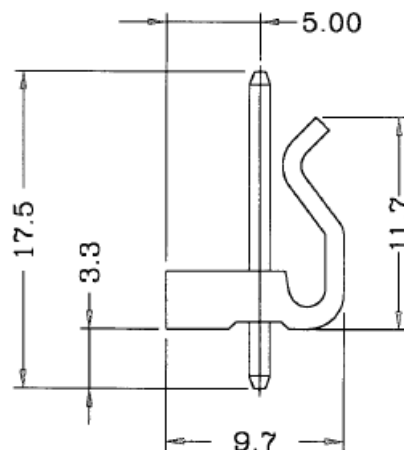
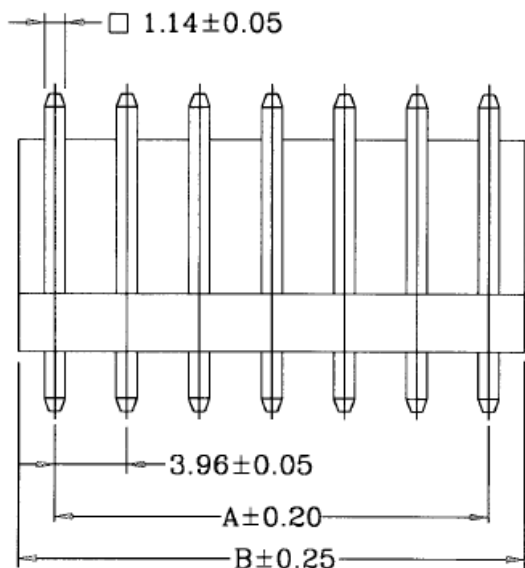
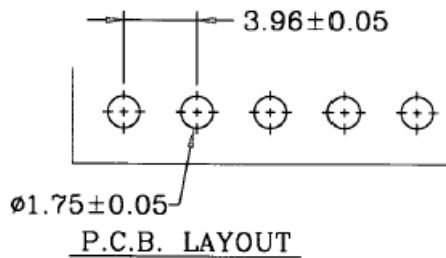
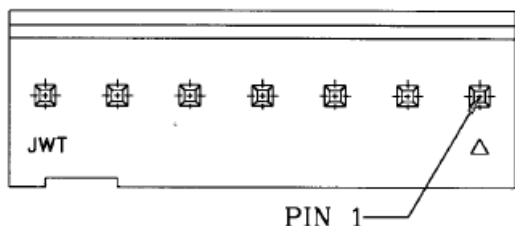

Dimensional & Ordering Information:

| Circuits | Part No | Dimensions | | PCS/BAG |
|----------|---------------|------------|-------|---------|
| | | A | B | |
| 2 | A3961WV2- 2P | 3.96 | 7.92 | 1000 |
| 3 | A3961WV2- 3P | 7.92 | 11.88 | 1000 |
| 4 | A3961WV2- 4P | 11.88 | 15.84 | 1000 |
| 5 | A3961WV2- 5P | 15.84 | 19.80 | 1000 |
| 6 | A3961WV2- 6P | 19.80 | 23.76 | 1000 |
| 7 | A3961WV2- 7P | 23.76 | 27.72 | 500 |
| 8 | A3961WV2- 8P | 27.72 | 31.68 | 500 |
| 9 | A3961WV2- 9P | 31.68 | 35.64 | 500 |
| 10 | A3961WV2- 10P | 35.64 | 39.60 | 300 |
| 11 | A3961WV2- 11P | 39.60 | 43.56 | 300 |
| 12 | A3961WV2- 12P | 43.56 | 47.52 | 200 |
| 13 | A3961WV2- 13P | 47.52 | 51.48 | 200 |
| 14 | A3961WV2- 14P | 51.48 | 55.44 | 200 |
| 15 | A3961WV2- 15P | 55.44 | 59.40 | 200 |

AC input Pin

| Pin number | Output Name | Wire Color | Wire AWG |
|------------|-------------|------------|----------|
| 1 | Line | | |
| 2 | NC | | |
| 3 | Netural | | |

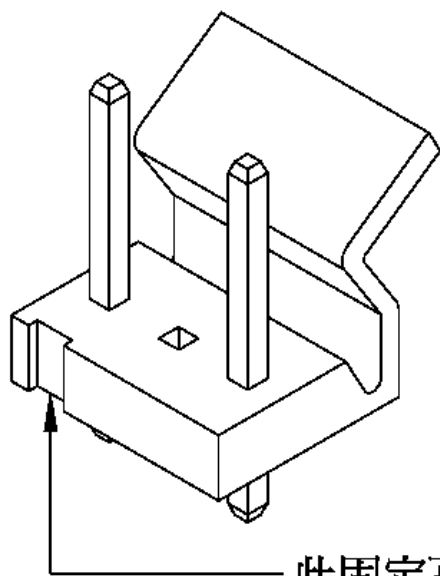
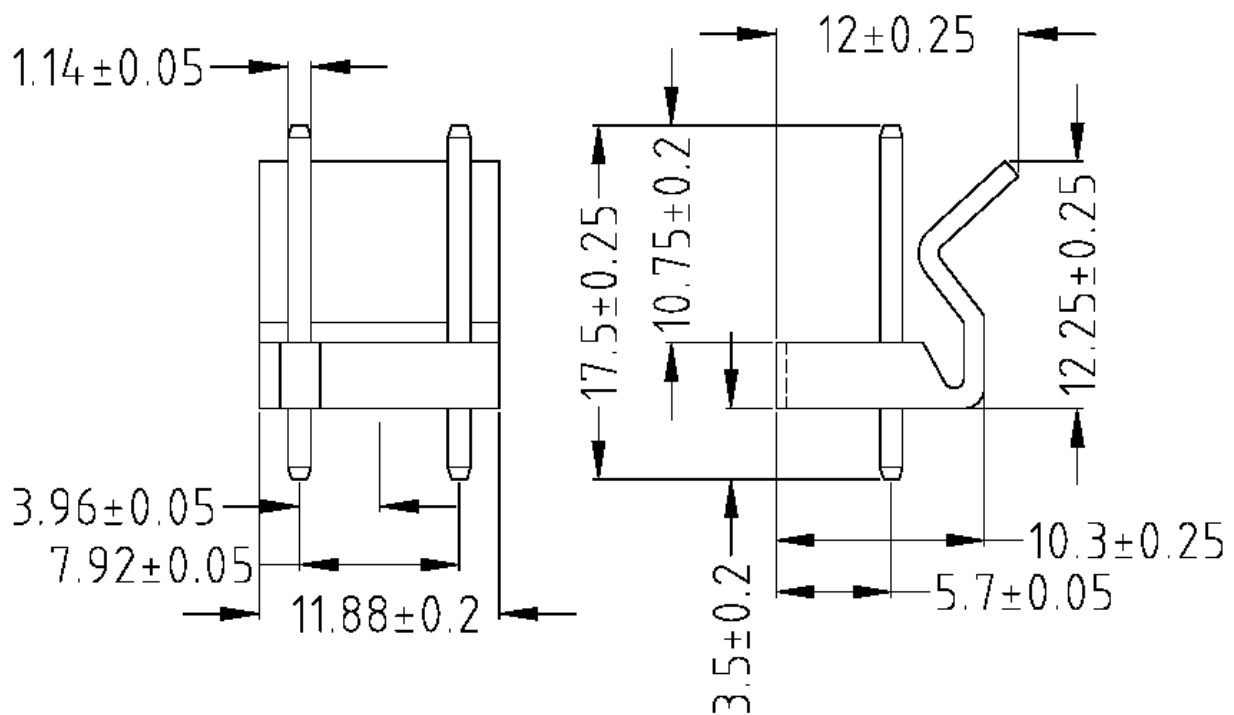

Insulator: Nylon 6/6 ul 94V-2
P.C board $\phi 1.8 \pm 0.1$

此固定孔無功能，故位置參考用。

3. ELECTRICAL REQUIREMENTS

3.1 Input AC

3.1.1 Input voltage

| Minimum | Nominal | Maximum | |
|---------|---------|---------|-----|
| 90 | 110/230 | 264 | VAC |

3.1.2 Input Frequency

| Min | Nominal | Max | |
|-----|---------|-----|----|
| 47 | 50/60 | 63 | Hz |

3.2 Output voltages and loads

Output voltage was measured at the load end of connected cables.

Table.1 SMPS load and regulation limits

A. Table 1 .Loading .

| Signal Name | Voltage (Volts) | | | | Current (A) | |
|-------------|-----------------|-------|-------|-------|-------------|---------|
| | Min | Typ | Max | | I max. | I min.. |
| +48V | 45.6 | 48.00 | 50.40 | +/-5% | 1.25 | 0.0 |

Note :

1. The output voltage shall within its regulation spec. under any line condition and I_{max} ,I_{min}. condition .

3.3 Ripple and Noise

3.3.1 Ripple and Noise required specification

Table.3 lists the Ripple and Noise limitations of switching power supply unit only under all operating conditions including the input line voltage range and over all the full load range.

Table.3 Ripple and Noise Limitations

| Signal Name | Ripple & Noise (mV) |
|-------------|---------------------|
| +48V | 250 |

Note:

1. The measuring is done by 20MHz bandwidth limited oscilloscope and terminated each output with a 10uF capacitor in parallel with a 0.1uF capacitor.
2. While test ripple noise of the output the probe shall avoid any coupling from other circuit or equipment .or the test result will not show power supply's actual ripple/noise .

3.4 Protection

The switching power supply will be auto recovery while the fault is removed.

3.4.1 Short circuit protection

Each DC output shall have short circuit protection. A short condition on any of DC outputs shall cause **no damage** to the power supply. The unit shall recover and function automatically as soon as the short condition is removed.

3.4.2 Fuse protection

The Fuse inside the power supply shall open when the AC input current is over the rated current of fuse. This Fuse protection will cause switching power supply to fail.

3.4.3 Over voltage protection

.The output have the over voltage protection. When the main feedback control circuit fault occur .The power supply shall be over voltage protection to protect the whole system.. The unit shall recover and function automatically as soon as the fault condition is removed.

3.5 Efficiency and Power consumption

Efficiency : >83% .

No load power consumption : 0.5Watts under AC 230V input

3.6 Hold-up time

The power supply shall maintain voltage regulation within the specified limits in table 1 for at least **20.0** milliseconds after losing of input voltage under the following conditions:

Input voltage: 230Vac

Loading: max output load

3.7 Mean Time Between Failure (MTBF)

100,000 hrs at 25 Degrees centigrade when calculated using MIL-HDBK-217F. Use agreed upon F.I.T. (failure – in - time) number in place of MTBF.

3.8 Feedback reliability

The power supply feedback circuit system shall be test under all the line and load condition .For the reliability consideration the gain margin shall be large 6db or phase margin large than 45 degree.

That's mean if power supply meet the spec describe above the feedback loop is in stably condition. There is no any oscillation phenomenon will occur.

4. ENVIRONMENTAL REQUIREMENTS

4.1 Operating Temperature

| | |
|-----------------|---------------|
| Power Operating | 5 to +50 °C |
| Storage | -20 to +65 °C |

Note :

- 1) Thermal test must be done at nom. AC and at I max. load.
- 2) Power supply shall be work under 70°C under half of max. loading .

4.2 Humidity (Non-condensing)

| | |
|-----------|--------------|
| Operating | 0% to 90% RH |
|-----------|--------------|

4.3 Vibration

10~55Hz,19.6m/sec² (2G), 3 minutes period ,60 minutes each along x,y,z axis

5. INTERNATIONAL STANDARDS

5.1 EMI standards and EMS standards

Designed to meet the following conducted & radiation limits:

- Electromagnetic emission must comply with EN55022 (1998) + A1 + A2 and EN55013 (2001)+A1 standards
- Electromagnetic immunity must comply with EN55020 (2002) + A1 and EN55024 (1998) +A1 + A2 standards
- EN61000-3-2
- EN61000-3-3 + A1
- EN61000-4-5 for surges
- Power Supply Transient Immunity shall be in conformance with surge testing as per EN61000-4-4 applying quick burst of power.
- Electrostatic Discharge Immunity shall be in conformance with EN61000-4-2
- Power shortage immunity shall be in conformance with immunity to 20 ms shortages as per EN61000-4-11
- EMC filtering is required on mains

5.2 Safety Compliance

IEC60950

IEC60065

5.4 RoHS Compliant

All the component of the power supply have to be RoHS compliant.