

REV.	DESCRIPTION	DRAWN	DATE
1	INITIAL RELEASE	FROS	2015/08/14
2	REVISED DRAWN NAME, AFTER -> BACK	FROS	2015/12/18

- SPECIFICATION:**
1. Current Rating: 0.2A AC/DC
 2. Voltage Rating: 50V AC/DC
 3. Contact Resistance: 100mΩ
 4. Insulation Resistance: 1,000MΩ
 5. Dielectric Withstanding Voltage: 150VAC
 6. Durability: 20 Cycle
 7. Reflow Peak Temp: 250°C, 3 Sec.

PIN	PART NO.	DIMENSIONS				
		A	B	C	D	E
17	317A-17BCA	6.60	5.70	4.20	4.80	5.43
19	317A-19BCA	7.20	6.30	4.80	5.40	6.03
21	317A-21BCA	7.80	6.90	5.40	6.00	6.63
23	317A-23BCA	8.40	7.50	6.00	6.60	7.23
25	317A-25BCA	9.00	8.10	6.60	7.20	7.83
27	317A-27BCA	9.60	8.70	7.20	7.80	8.43
29	317A-29BCA	10.20	9.30	7.80	8.40	9.03
31	317A-31BCA	10.80	9.90	8.40	9.00	9.63
33	317A-33BCA	11.40	10.50	9.00	9.60	10.23
35	317A-35BCA	12.00	11.10	9.60	10.20	10.83
37	317A-37BCA	12.60	11.70	10.20	10.80	11.43
39	317A-39BCA	13.20	12.30	10.80	11.40	12.03
41	317A-41BCA	13.80	12.90	11.40	12.00	12.63
43	317A-43BCA	14.40	13.50	12.00	12.60	13.23
45	317A-45BCA	15.00	14.10	12.60	13.20	13.83

4	TERMINAL B	PHOSPHOR BRONZE C5210R-SH 0.1T, CONTACT AREA 5u" GOLD, SOLDER AREA GOLD FLASH, UNDER 50u" NICKEL PLATED
3	TERMINAL A	
2	COVER	LCP MG350HF, UL94V-0, NATURAL
1	HOUSING	LCP HA475, UL94V-0, BLACK
NO.	PART NAME	DESCRIPTION

UNLESS OTHERWISE SPECIFIED TOLERANCE			
UNIT:	DECIMAL	LINEAR	ANGLES
mm	X.	±0.50	±5°
	X.X	±0.25	±3°
	X.XX	±0.12	±1°



WWW.ATTEND.COM.TW

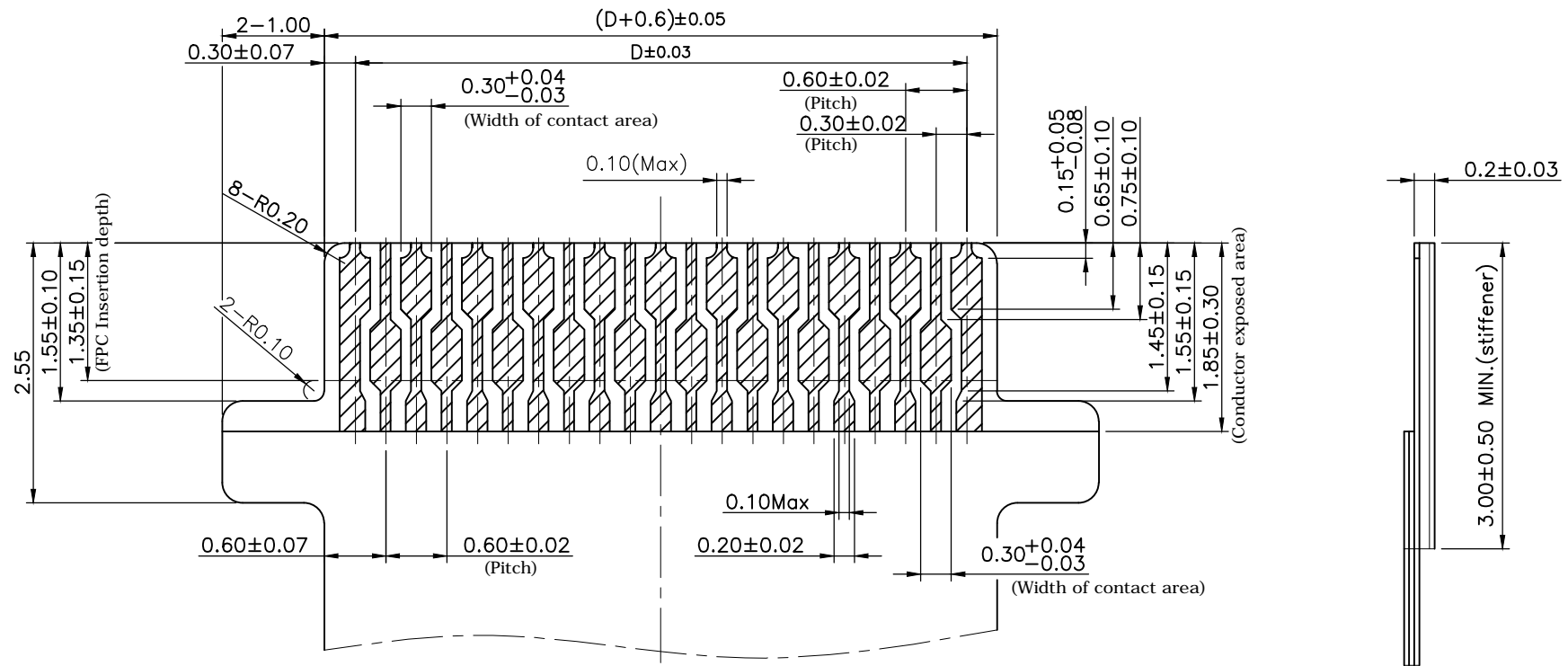

DRAWN	Fros	2015/08/14	DRAWN NAME:	FPC CONNECTOR, 0.3 PITCH	
CHECKED	Zola	2015/08/14		H=0.9mm, BACK FLIP SMT TYPE	
APPROVED	Ken	2015/08/14	PRODUCT NO.	SEE P/N TABLE	
SCALE	10/1	SHEET	1/7	SIZE	A4
FILE NAME	317A-XXBCA_B_2				

REV.	DESCRIPTION	DRAWN	DATE
	SEE SHEET ONE		



PIN	DIM. D
17	4.80
19	5.40
21	6.00
23	6.60
25	7.20
27	7.80
29	8.40
31	9.00
33	9.60
35	10.20
37	10.80
39	11.40
41	12.00
43	12.60
45	13.20

With insertion confirming tabs and lead plating
(21 PIN)

UNLESS OTHERWISE SPECIFIED TOLERANCE				 WWW.ATTEND.COM.TW		
UNIT:	DECIMAL	LINEAR	ANGLES			
mm	X.	±0.50	±5°			
	X.X	±0.25	±3°			
	X.XX	±0.12	±1°			
DRAWN	Fros	2015/08/14	DRAWN NAME:			
CHECKED	Zola	2015/08/14	FPC CONNECTOR, 0.3 PITCH H=0.9mm, BACK FLIP SMT TYPE			
APPROVED	Ken	2015/08/14	PRODUCT NO.	SEE P/N TABLE		
 SCALE 15/1		SHEET 3/7	SIZE A4	FILE NAME	317A-XXBCA_B_2	

REV.	DESCRIPTION	DRAWN	DATE
	SEE SHEET ONE		

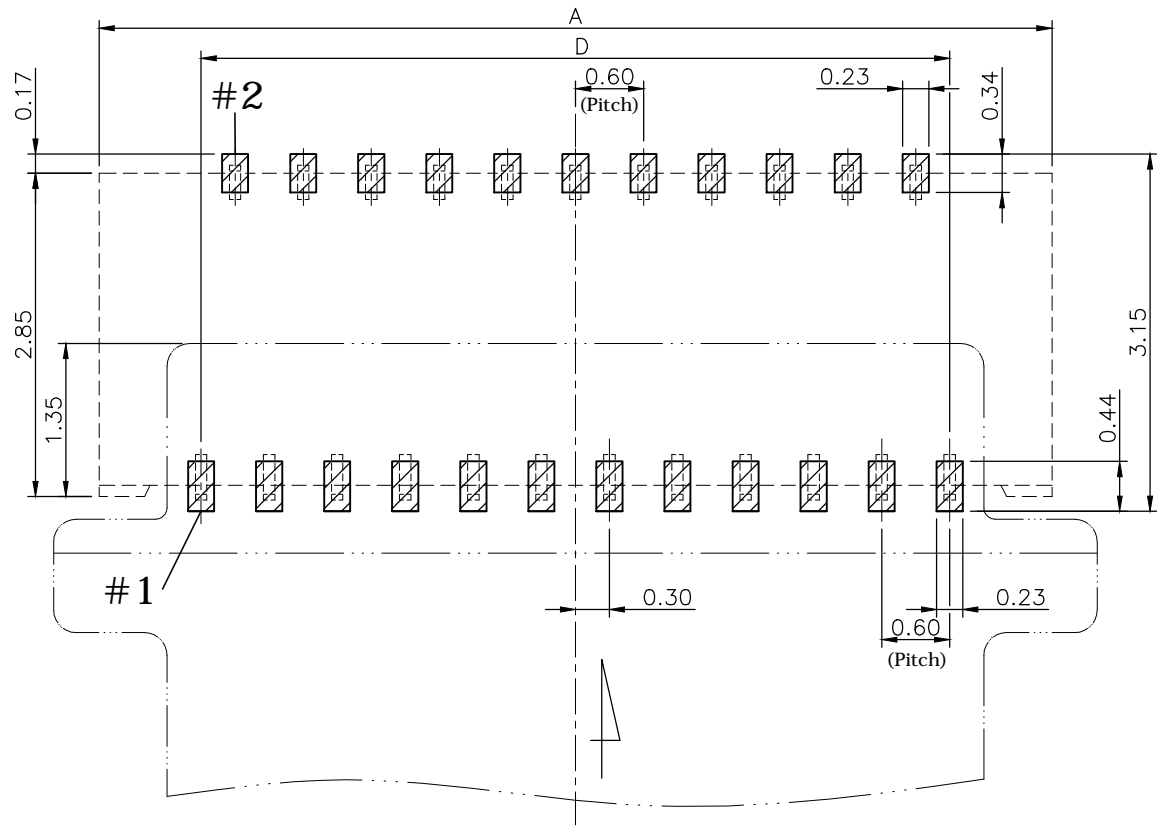

PIN	DIM.	
	A	D
17	6.60	4.80
19	7.20	5.40
21	7.80	6.00
23	8.40	6.60
25	9.00	7.20
27	9.60	7.80
29	10.20	8.40
31	10.80	9.00
33	11.40	9.60
35	12.00	10.20
37	12.60	10.80
39	13.20	11.40
41	13.80	12.00
43	14.40	12.60
45	15.00	13.20

RECOMMENDED LAYOUT (TOP VIEW)
GENERAL TOLERANCE: ±0.03mm
(23 PIN)

- PAD
- Socket
- FPC

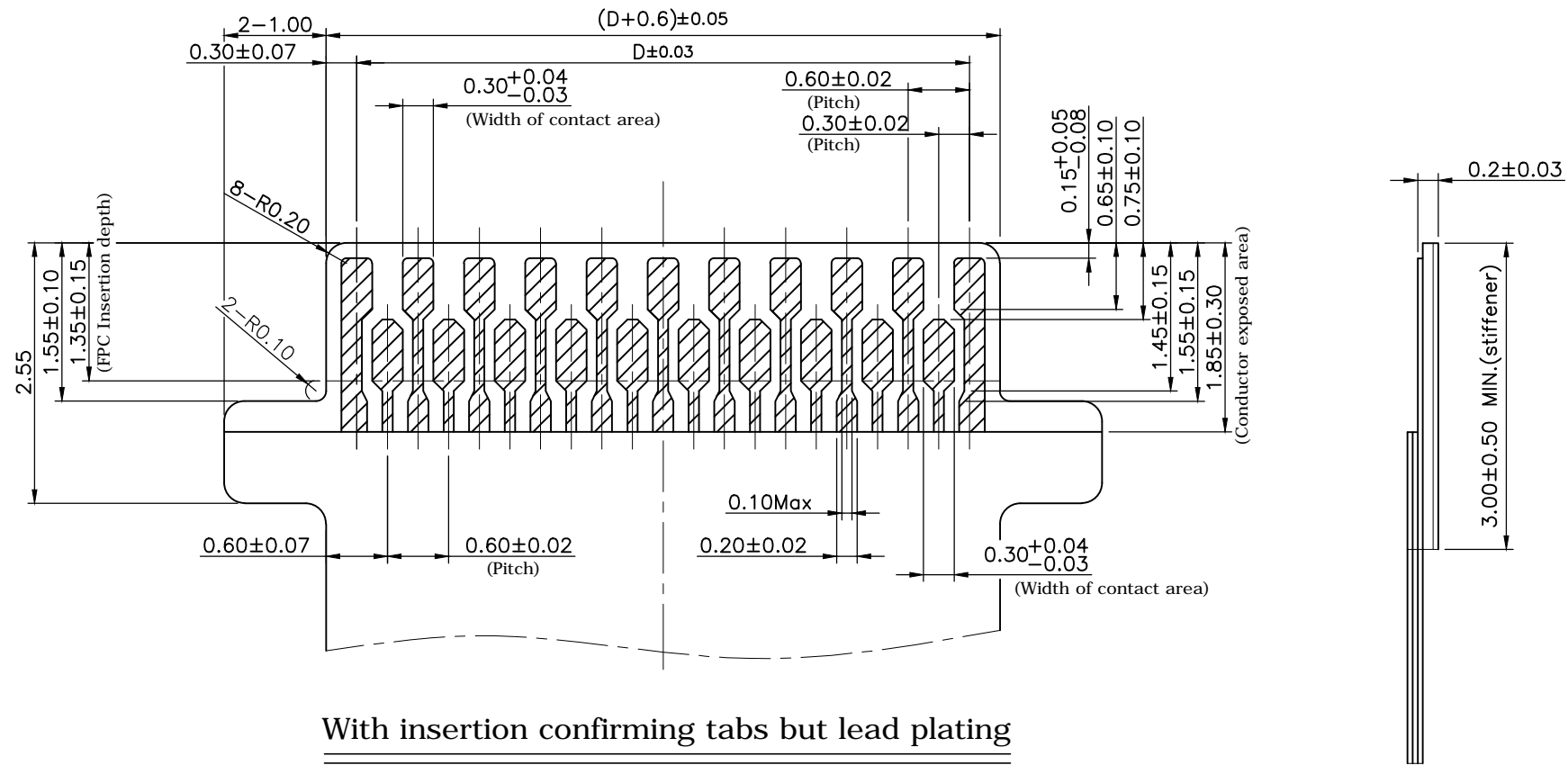

UNLESS OTHERWISE SPECIFIED TOLERANCE					
UNIT:	DECIMAL	LINEAR	ANGLES		
mm	X.	±0.50	±5°	DRAWN NAME: FPC CONNECTOR, 0.3 PITCH H=0.9mm, BACK FLIP SMT TYPE	
	X.X	±0.25	±3°		
	X.XX	±0.12	±1°		
DRAWN	Fros	2015/08/14	DRAWN NAME:		
CHECKED	Zola	2015/08/14	FPC CONNECTOR, 0.3 PITCH		
APPROVED	Ken	2015/08/14	H=0.9mm, BACK FLIP SMT TYPE		
SCALE		SHEET	SIZE	PRODUCT NO. SEE P/N TABLE	
15/1		2/7	A4	FILE NAME 317A-XXBCA_B_2	

REV.	DESCRIPTION	DRAWN	DATE
	SEE SHEET ONE		



PIN	DIM. D
17	4.80
19	5.40
21	6.00
23	6.60
25	7.20
27	7.80
29	8.40
31	9.00
33	9.60
35	10.20
37	10.80
39	11.40
41	12.00
43	12.60
45	13.20

**With insertion confirming tabs but lead plating
(21 PIN)**

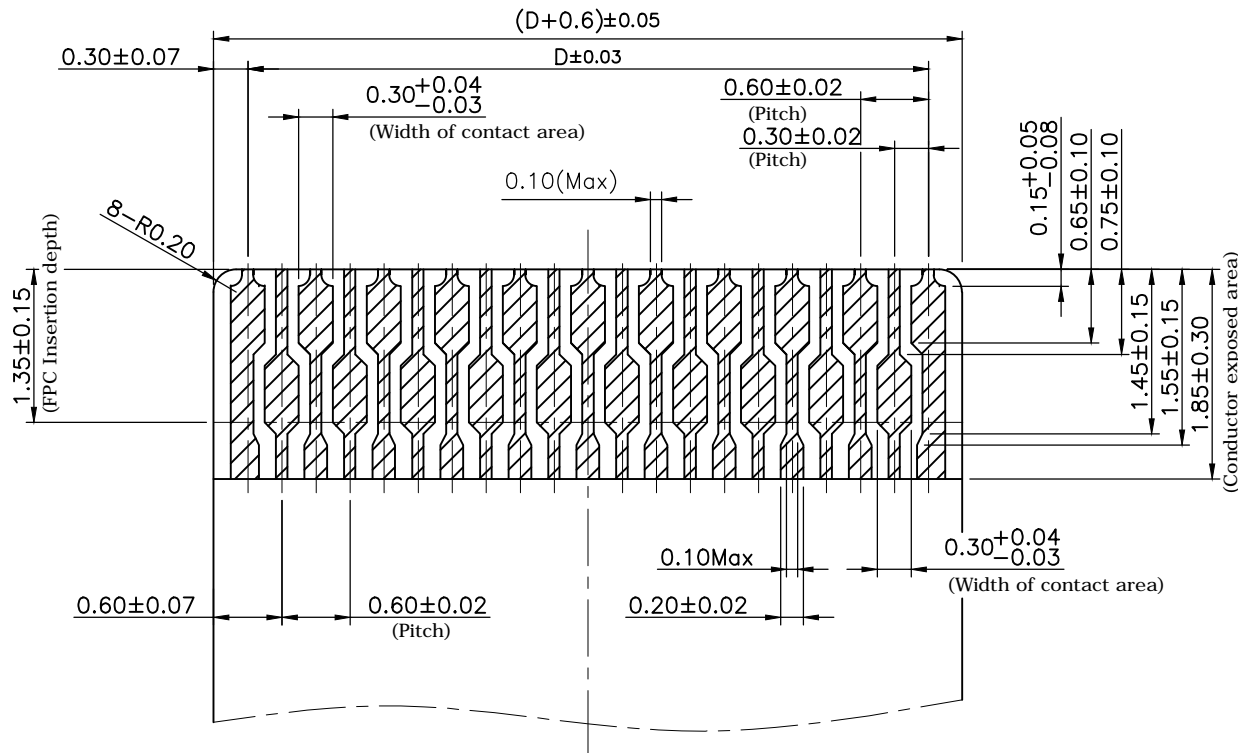

UNLESS OTHERWISE SPECIFIED TOLERANCE				 WWW.ATTEND.COM.TW	
UNIT:	DECIMAL	LINEAR	ANGLES		
mm	X.	±0.50	±5°		
	X.X	±0.25	±3°		
	X.XX	±0.12	±1°		
DRAWN	Fros	2015/08/14	DRAWN NAME:		
CHECKED	Zola	2015/08/14	FPC CONNECTOR, 0.3 PITCH H=0.9mm, BACK FLIP SMT TYPE		
APPROVED	Ken	2015/08/14	PRODUCT NO.	SEE P/N TABLE	
 SCALE 15/1		SHEET 4/7	SIZE A4	FILE NAME	317A-XXBCA_B_2

REV.	DESCRIPTION	DRAWN	DATE
	SEE SHEET ONE		



PIN	DIM. D
17	4.80
19	5.40
21	6.00
23	6.60
25	7.20
27	7.80
29	8.40
31	9.00
33	9.60
35	10.20
37	10.80
39	11.40
41	12.00
43	12.60
45	13.20

Without insertion confirming tabs but lead plating
(21 PIN)

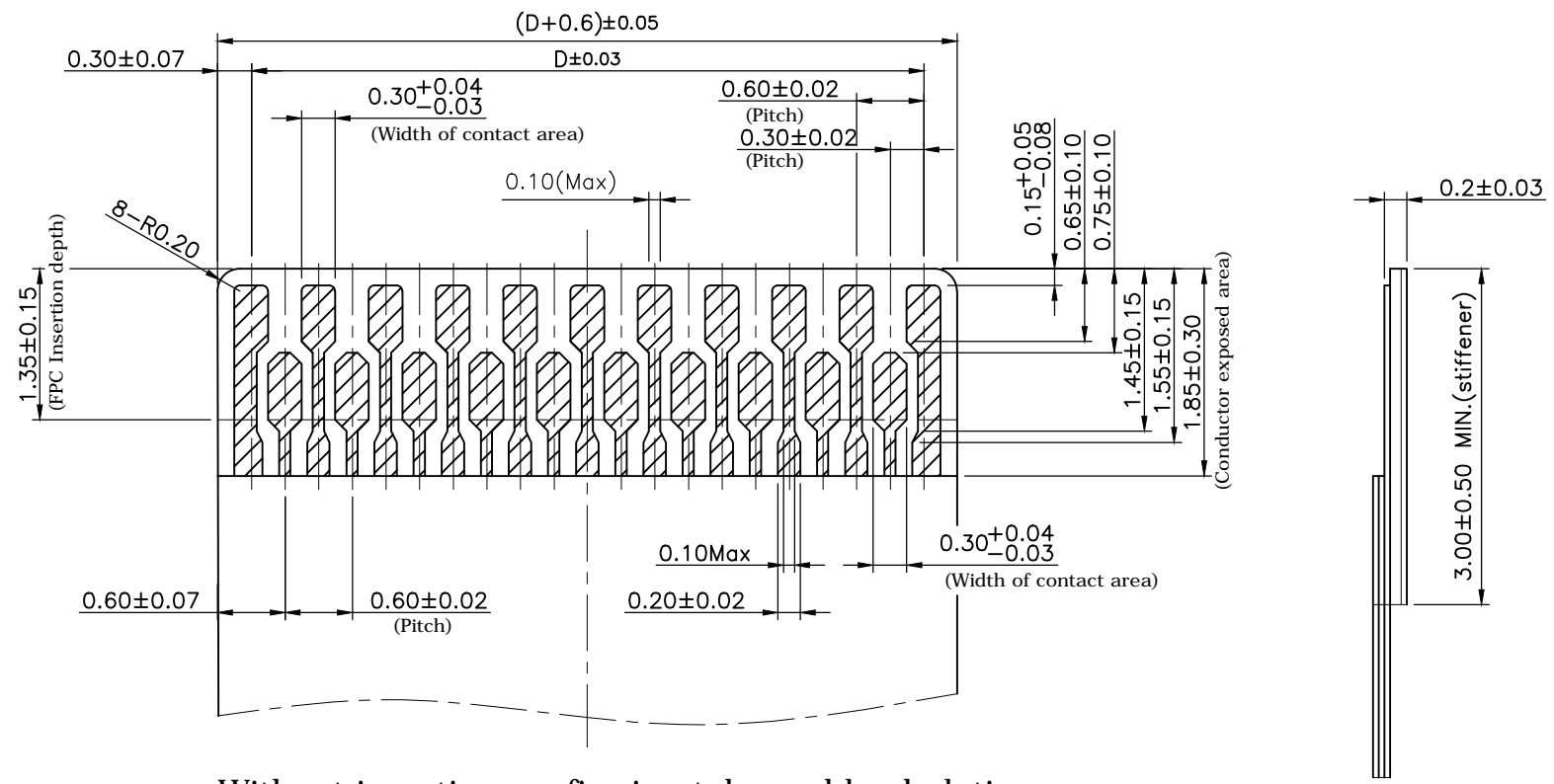

UNLESS OTHERWISE SPECIFIED TOLERANCE				 WWW.ATTEND.COM.TW
UNIT:	DECIMAL	LINEAR	ANGLES	
mm	X.	±0.50	±5°	
	X.X	±0.25	±3°	
	X.XX	±0.12	±1°	
DRAWN	Fros	2015/08/14	DRAWN NAME:	
CHECKED	Zola	2015/08/14	FPC CONNECTOR, 0.3 PITCH H=0.9mm, BACK FLIP SMT TYPE	
APPROVED	Ken	2015/08/14	PRODUCT NO. SEE P/N TABLE	
	SCALE	SHEET	SIZE	FILE NAME
	15/1	5/7	A4	317A-XXBCA_B_2

REV.	DESCRIPTION	DRAWN	DATE
	SEE SHEET ONE		



PIN	DIM. D
17	4.80
19	5.40
21	6.00
23	6.60
25	7.20
27	7.80
29	8.40
31	9.00
33	9.60
35	10.20
37	10.80
39	11.40
41	12.00
43	12.60
45	13.20

Without insertion confirming tabs and lead plating
 (21 PIN)

UNLESS OTHERWISE SPECIFIED TOLERANCE				 WWW.ATTEND.COM.TW		
UNIT:	DECIMAL	LINEAR	ANGLES			
mm	X.	±0.50	±5°			
	X.X	±0.25	±3°			
	X.XX	±0.12	±1°			
DRAWN	Fros	2015/08/14	DRAWN NAME:			
CHECKED	Zola	2015/08/14	FPC CONNECTOR, 0.3 PITCH H=0.9mm, BACK FLIP SMT TYPE			
APPROVED	Ken	2015/08/14	PRODUCT NO.	SEE P/N TABLE		
 SCALE 15/1		SHEET 6/7	SIZE A4	FILE NAME	317A-XXBCA_B_2	

REV.	DESCRIPTION	DRAWN	DATE
	SEE SHEET ONE		

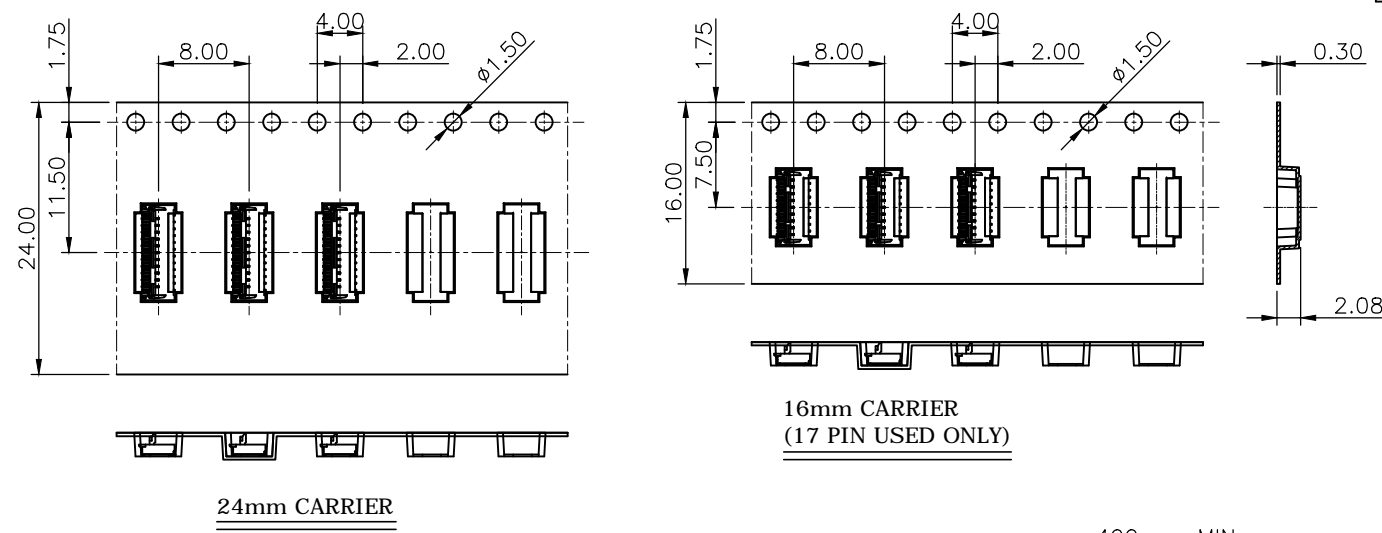

PACKING SPECIFICATION:

1. Carrier Tape Material: Thermoplastic anti-static film or equivalent, 0.25 to 0.35mm, transparent
2. Reel Material: PS, BLUE
3. Peel Strength: Requirement of cover tape to comply with EIA-481
4. All tape and sprocket hole dimensions shown are per EIA-481

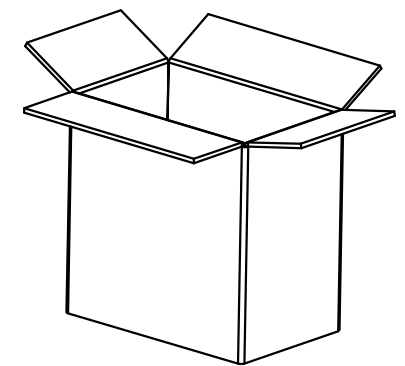
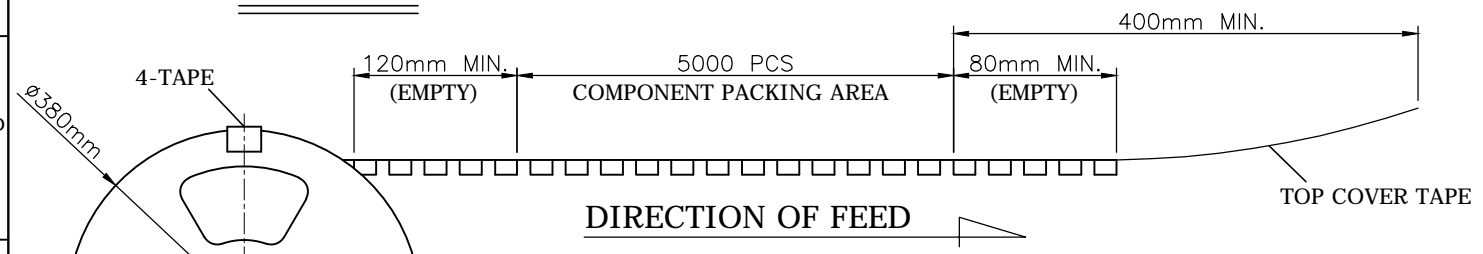

CARTON
400X400X150mm

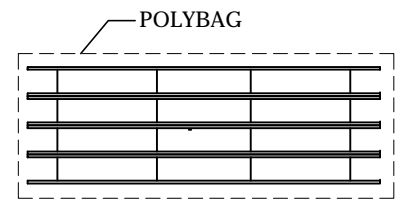

24mm TYPE

Carton containing
4 Reels (19 to 45 pin)
4X5,000= 20,000 PCS

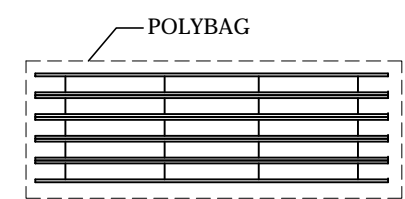

16mm TYPE

Carton containing
5 Reels (17 pin)
5X5,000= 25,000 PCS

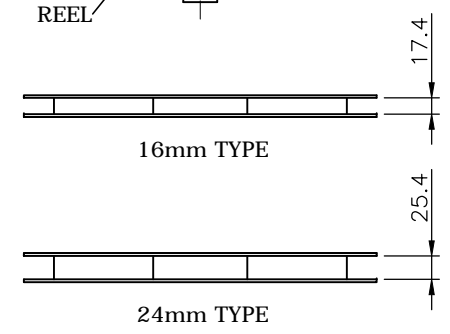

UNLESS OTHERWISE SPECIFIED TOLERANCE				
UNIT:	DECIMAL	LINEAR	ANGLES	
mm	X.	±0.50	±5°	
	X.X	±0.25	±3°	
	X.XX	±0.12	±1°	
DRAWN	Fros	2015/08/14	DRAWN NAME: FPC CONNECTOR, 0.3 PITCH H=0.9mm, BACK FLIP SMT TYPE	
CHECKED	Zola	2015/08/14		
APPROVED	Ken	2015/08/14		
SCALE	N/A	SHEET 7/7	SIZE A4	FILE NAME 317A-XXBCA_B_2



WWW.ATTEND.COM.TW

