

# **(DC)TR-52D**

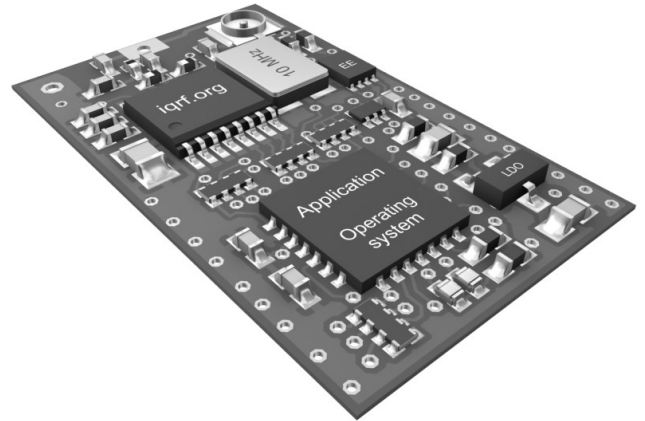
**Transceiver Module**

## **Data Sheet**



## Description

TR-52D is a family of IQRF transceiver modules operating in the 868 MHz and 916 MHz license free ISM (Industry, Scientific and Medical) frequency band. Its highly integrated ready-to-use design requires no external components. Microcontroller with built-in operating system, excellent development support, integrated LDO regulator, serial EEPROM and optional temperature sensor dramatically reduce time of application development. Ultra low power consumption predetermines these modules for use in battery powered applications.



This document is valid for TR as well as DCTR transceiver versions. For simplicity, only TR is used further on throughout the document.

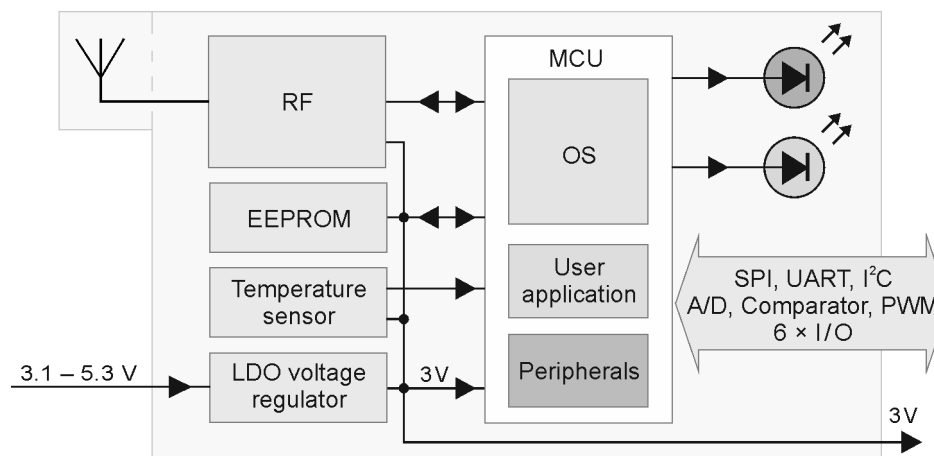
## Key features

- Complete solution with operating system, easy to use
- FSK modulation
- Selectable RF band 868 / 916 MHz, multiple channel
- MCU with extended resources, user interrupt capability
- Extra low power consumption, power management modes
- SPI interface supported by OS on background
- Serial EEPROM
- PWM output
- Programmable HW timer
- +3 V LDO regulator output, battery monitoring
- 2 LEDs
- 8 pins, 6 I/Os
- A/D converter (2 channels), analog comparator
- Options: on-board antenna, U.FL connector, temperature sensor
- SIM card format

## Applications

- Telemetry
- Building automation
- Wireless control & regulation
- Access control
- Remote data acquisition
- Communication links
- RF connectivity in many other areas

## Block diagram



Information contained in this publication regarding device applications and the like is provided only for your convenience and may be superseded by updates. It is your responsibility to ensure that your application meets with your specifications.

MICRORISC MAKES NO REPRESENTATIONS OR WARRANTIES OF ANY KIND TO STATED CONDITION, QUALITY, PERFORMANCE, MERCHANTABILITY OR FITNESS FOR PURPOSE and disclaims all liability arising from this information and its use. Use of MICRORISC devices in life support and/or safety applications is entirely at the buyer's risk, and the buyer agrees to defend, indemnify and hold harmless MICRORISC from any and all damages, claims, suits, or expenses resulting from such use. No licenses are conveyed, implicitly or otherwise, under any MICRORISC intellectual property rights.

**Electrical specifications**
*Typical values unless otherwise stated*

Parameters specified in this datasheet are typical values. They are at power supply  $V_{OUT} = 3\text{ V}$  only.  $V_{OUT}$  voltage different from 3 V can impact on RF range and other parameters.

Supply voltage ( $V_{CC}$ )	3.1 V to 5.3 V
LDO output ( $V_{OUT}$ )	+3 V $\pm$ 60 mV ( $V_{CC} > 3.1\text{ V}$ ), 100 mA max.
Operating temperature <sup>1</sup>	-40 °C to +85 °C
Supply current	
Sleep mode	1.9 $\mu$ A (if all peripherals including MRF49XA disabled <sup>3</sup> )
Run mode	1 mA (MRF49XA disabled), 1.6 mA (MRF49XA enabled)
Additional LED supply current	cca 2 mA (if one or two LEDs on). Rough value for brief guidance only.
RX mode	STD mode: 13 mA LP mode <sup>4</sup> : OS v3.01D: 400 $\mu$ A, from OS v3.02D: 330 $\mu$ A XLP mode <sup>4</sup> : OS v3.01D: 35 $\mu$ A, from OS v3.02D: 25 $\mu$ A
TX mode	14 mA – 24 mA (according to RF output power)
RF Band	868 MHz or 916 MHz (software selectable)
Channels	See IQRF OS User's guide, Appendix 2, Channel maps
RF data modulation	FSK (frequency-shift keying)
RF data transmission bit rate	1.2 kb/s <sup>5</sup> , 19.2 kb/s, 57.6 kb/s <sup>5</sup> , 86.2 kb/s <sup>5</sup>
RFIC RF sensitivity	See MRF49XA datasheet
RFIC RF output power	Programmable in 8 levels (0 – 7), -2.5 dBm/level, see MRF49XA datasheet
RF range (TR-52DAx) <sup>2</sup>	Up to 300 m @ 19.2 kb/s <sup>5</sup>
Input voltage on C1, C2, C5 to C8 pins	0 V to $V_{OUT}$
A/D converter	10 bit, 2 inputs, see PIC16LF1938 datasheet
Temperature sensor	TMP112 (for TR-52DT and TR-52DxT only)
Size (L x W x H)	25.0 mm x 14.9 mm x 2.0 mm 31.8 mm x 14.9 mm x 2.0 mm (TR-52DA)

**Note 1:** RF range may change with lower temperature. Frost, condensation or humidity over 85% may disable module functionality. Module suitability should be tested in final application before volume use.

**Note 2:** RF range strongly depends on module orientation and surroundings.

**Note 3:** Additional current is consumed when a peripheral (e.g. watchdog, Brown-out detection etc.) is enabled.

**Note 4:** Depends on interferences.

**Note 5:** RF bit rates different from 19.2 kb/s are preliminary, for experimental purpose only.

Users have to ensure observing local provisions and restrictions relating to the use of short range devices by software, e.g. the CEPT ERC/REC 70-03 Recommendation and subsequent amendments in EU.

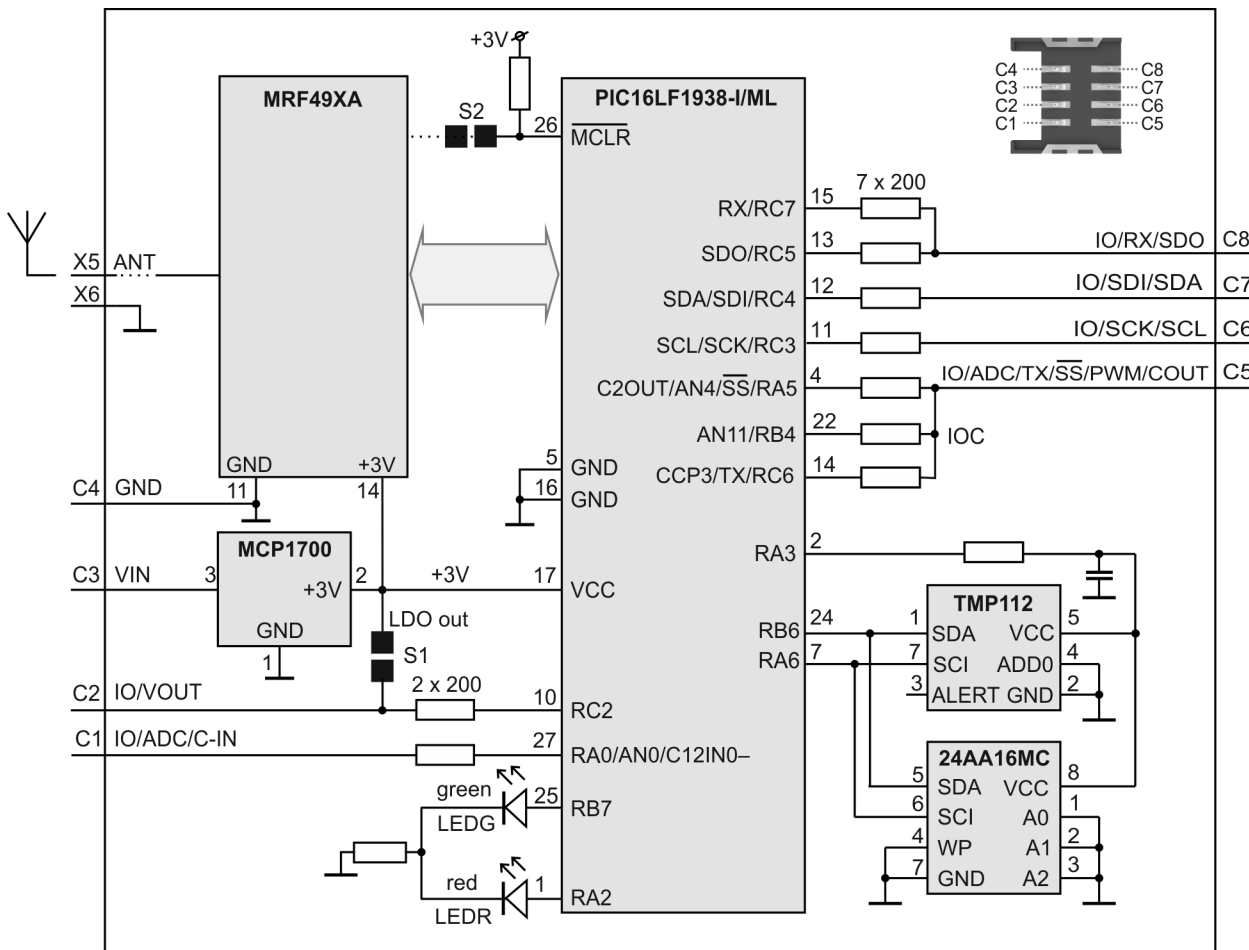
TR modules with metallic shielding of RF circuitry (with the "F" postfix, e.g. TR-52DF) must be used in countries where FCC provision is valid.

**Caution:** Electrostatic sensitive device. Observe appropriate precautions for handling

**Absolute maximum ratings**

*Stresses above listed maximum values may cause permanent damage to the device and affect device reliability. Functional operation at these or any other conditions beyond those specified is not supported.*

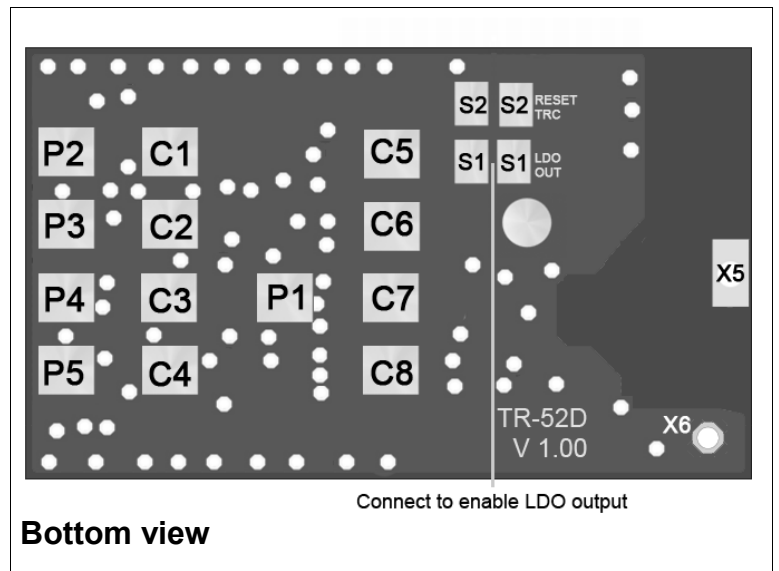
Supply voltage (V <sub>CC</sub> )	5.5 V
Voltage on C1, C2, C5 to C8 pins vs. GND	-0.3 V to (V <sub>OUT</sub> + 0.3 V)
Storage temperature	-40 °C to +85 °C
Ambient temperature under bias	-40 °C to +85 °C

**Simplified schematic**

**Basic components**

IC	Type	Manufacturer	Note
<b>MCU</b>	PIC16LF1938-I/ML	Microchip	
<b>RF IC</b>	MRF49XA	Microchip	
<b>LDO voltage regulator</b>	MCP1700	Microchip	
<b>Temperature sensor</b>	TMP112	Texas Instruments	TR-52DT, TR-52DCT and TR-52DAT only
<b>EEPROM</b>	24AA16/MC	Microchip	

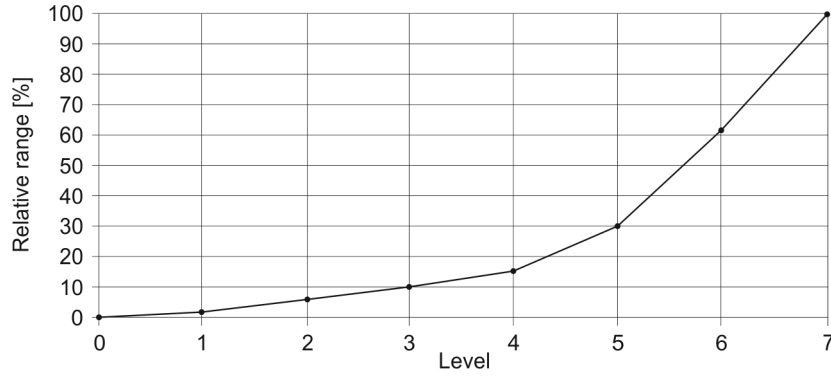
For more information refer to datasheets of ICs used.

Pin	Name	Description
C1	<b>IO/ADC/C-IN</b>	
	RA0	General I/O pin
	AN0	Analog A/D input
	C12IN0	Comparator –input
C2	<b>IO/VOUT</b>	
	RC2	General I/O pin (S1 disconnected)
	VOUT	On-board +3 V LDO output (S1 connected)
C3	<b>VIN</b>	Power supply voltage
C4	<b>GND</b>	Ground
C5	<b>IO/ADC/TX/-SS /PWM/COUT</b>	
	RA5	General I/O pin,
	-SS	SPI Slave select
	AN4	Analog A/D input
	C2OUT	Comparator output
	RC6	General I/O pin
	TX	UART TX
	CCP3	PWM output
	RB4	General I/O pin, programmable pull-up and interrupt/wake-up on change (IOC), RFPGM termination
	AN11	Analog A/D input
	C6	<b>IO/SCK/SCL</b>
RC3		General I/O pin
SCK		SPI clock input
SCL		I <sup>2</sup> C clock
C7	<b>IO/SDI/SDA</b>	
	RC4	General I/O pin
	SDI	SPI data
	SDA	I <sup>2</sup> C data
C8	<b>IO/RX/SDO<sup>6</sup></b>	
	RC5	General I/O pin
	SDO	SPI data out
	RC7	General I/O pin
	RX	UART RX
X5	<b>ANT</b>	Antenna input
X6	<b>GND</b>	Ground
P1–P5		For manufacturer only
S1		LDO output enable. Connect to enable (default disabled).
S2		Leave disconnected.

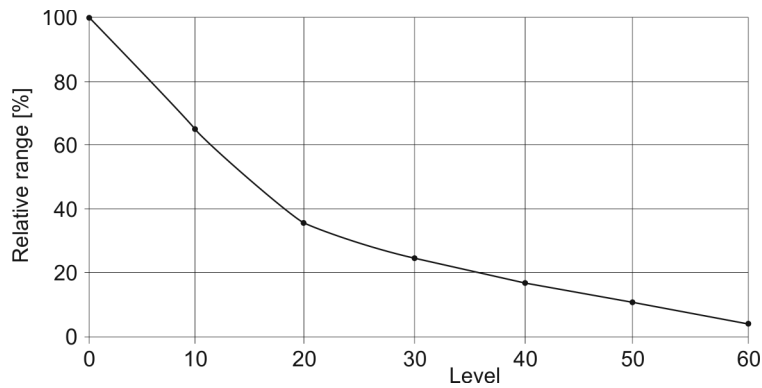


**Note 6:** This pin is used as output during initial ~250 ms boot-up to recognize programming mode.

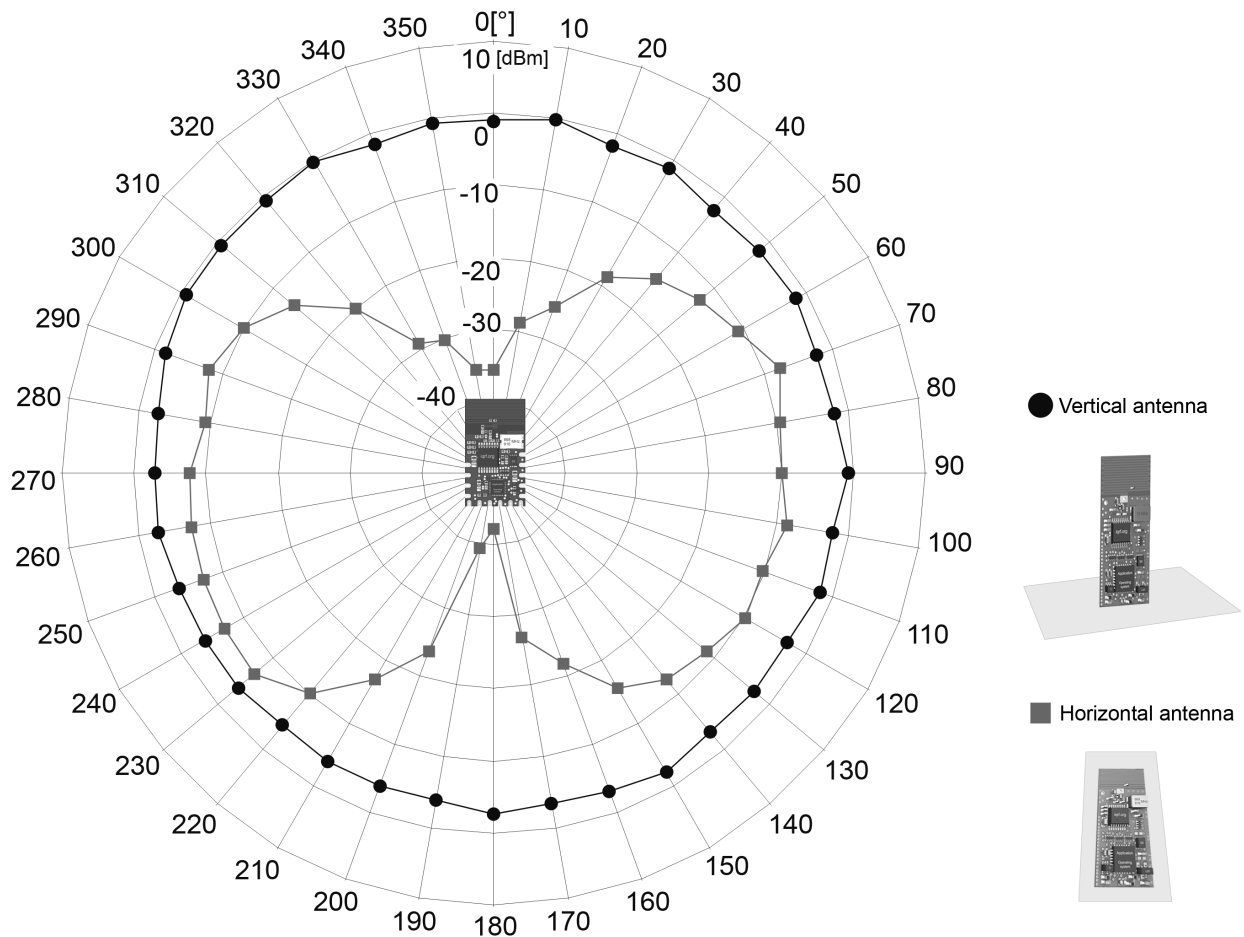
**Figure 1:** Relative RF range vs. level for the `setTxpower(level)` function. Refer to IQRF OS Reference guide.



**Figure 2:** Relative RF range vs. level for the `checkRF(level)` function. Refer to IQRF OS Reference guide.

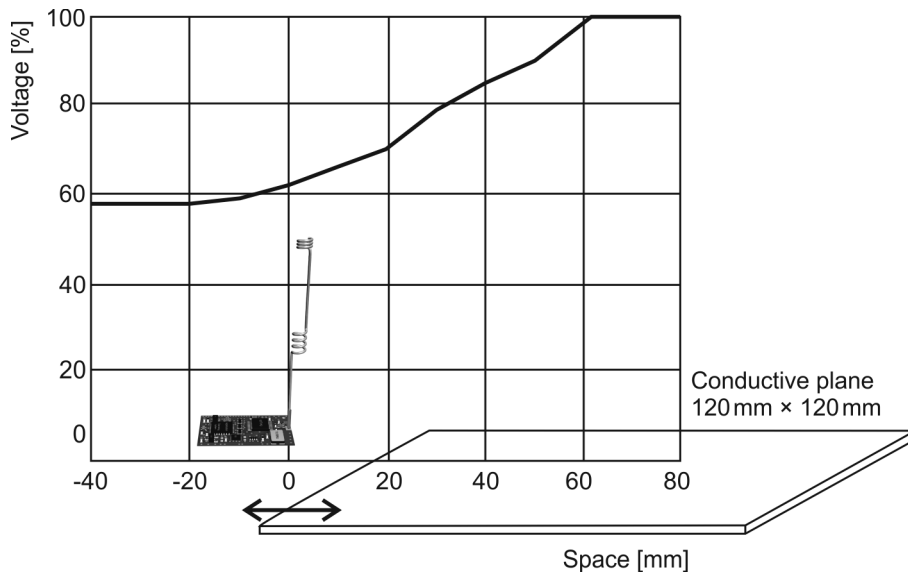
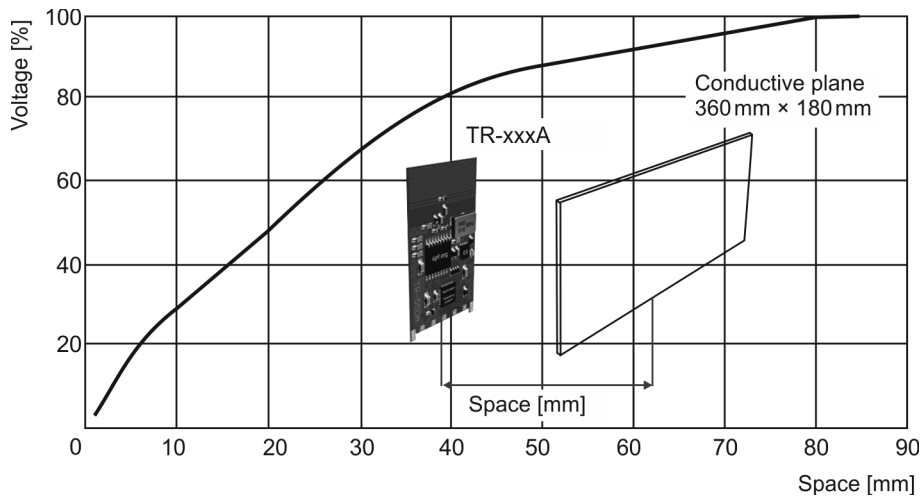


**Figure 3:** TR-52DA relative RF range vs. antenna orientation (radiation patterns)



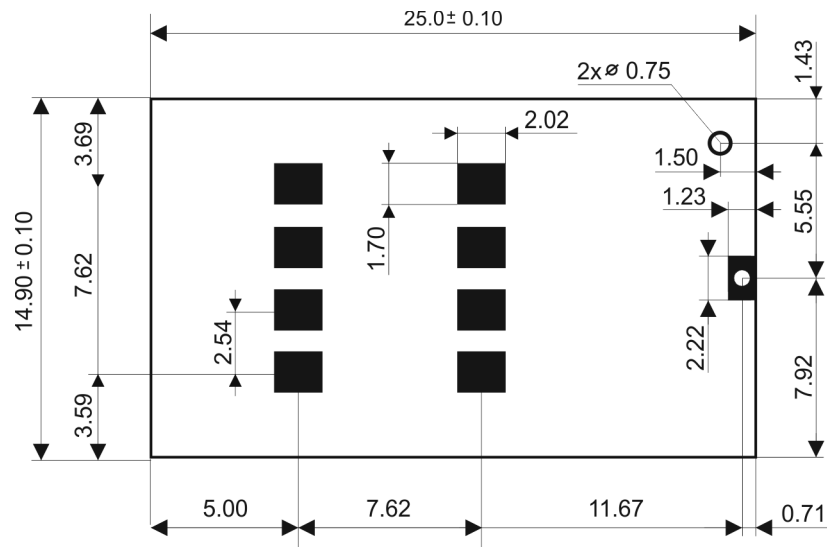
**Relative decrease of RF input signal vs. antenna edge spacing to conductive areas**

Conductive areas close to the antenna must be avoided.

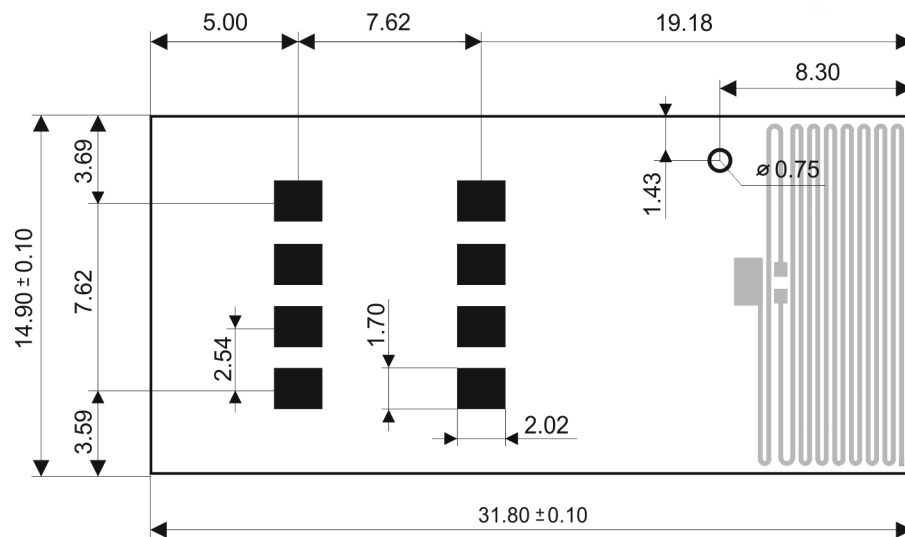
**Figure 4: Perpendicular arrangement**

**Figure 5: Parallel arrangement**


## Dimensions

TR-52D(C)(T)



TR-52DA(T)



Top view, Units: mm



---

## **Application**

---

### **Assembly**

TR-52Dx modules should be mounted in SIM connector. They are not intended for SMT reflow soldering. Recommended SIM connector: KON-SIM-01.

### **Operating system**

See IQRF OS User's guide and IQRF OS Reference guide.

### **Software**

See Application examples on [www.iqrf.org](http://www.iqrf.org) website.

### **Programming**

There are the following possibilities to upload an application program in TR-52Dx modules:

- Wired upload with TR-52Dx plugged via the SIM connector in the CK-USB-04 or CK-USB-04A programmer.
- For TR-52Dx modules populated in an application:
  - Wired upload using the CK-USB-04A programmer. See the CK-USB-04A User's guide.
  - Wired upload using the CK-USB-04 programmer and the KON-TR-01P adapter. See the KON-TR-01P User's guide.
  - RFPGM – RF programming™ (wireless upload). See the IQRF OS User's guide, Appendix *RF programming*.

In countries where FCC provision is valid, the requirements stated in CB-400-Modular Approval Checklist\_JS\_WIP.pdf have to be observed. Refer to [www.iqrf.org/download](http://www.iqrf.org/download), „FCC checklist“.

This equipment has been tested and found to comply with the limits for a Class B digital device, pursuant to part 15 of the FCC Rules. These limits are designed to provide reasonable protection against harmful interference in a residential installation. This equipment generates, uses and can *radiate* radio frequency energy and, if not installed and used in accordance with the instructions, may cause harmful interference to radio communications. However, there is no guarantee that interference will not occur in a particular installation. If this equipment does cause harmful interference to radio or television reception, which can be determined by turning the equipment off and on, the user is encouraged to try to correct the interference by one or more of the following measures:

- Reorient or relocate the receiving antenna.
- Increase the separation between the equipment and receiver.
- Connect the equipment into an outlet on a circuit different from that to which the receiver is connected.
- Consult IQRF support or an experienced local distributor technician for help.

## Product information

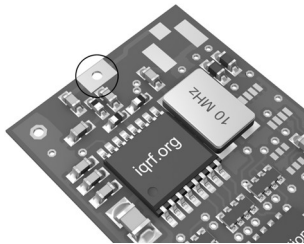
### Ordering codes

T R - 5 2 D A PP

- Peripheral options: **ni1** - No other option  
**T** - Temperature sensor  
**F** - RF shielding
- Antenna options: **ni1** - soldering padhole (no antenna, no U.FL connector)  
**A** - PCB antenna,  
**C** - U.FL connector (mini coax)

Type	Antenna connection	Temperature sensor	RF shielding
TR-52D	Soldering hole	-	-
TR-52DC	U.FL connector	-	-
TR-52DA	PCB antenna	-	-
TR-52DF	Soldering hole	-	Yes
TR-52DCF	U.FL connector	-	Yes
TR-52DAF	PCB antenna	-	Yes

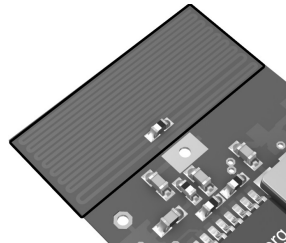
Type	Antenna connection	Temperature sensor	RF shielding
TR-52DT	Soldering hole	Yes	-
TR-52DCT	U.FL connector	Yes	-
TR-52DAT	PCB antenna	Yes	-
TR-52DTF	Soldering hole	Yes	Yes
TR-52DCTF	U.FL connector	Yes	Yes
TR-52DATF	PCB antenna	Yes	Yes



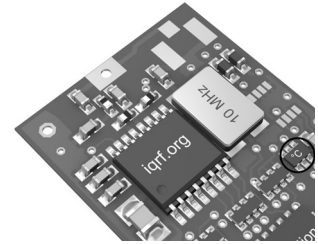
TR-52D



TR-52DC



TR-52DA



TR-52DT



TR-52DF

**Document history**

- 150810 Supply current in Run mode slightly revised
- 141219 Information regarding FCC directives updated.
- 141103 Chapters *Pin description* and *Programming* slightly updated.  
Information regarding directives FCC, RoHS and WEEE updated and extended.
- 140430 RF range revised.
- 140120 Datasheet file renamed from DS\_TR-52D\_131114 to Datasheet\_TR-52D\_140120.
- 131114 Certification updated for the latest directives.
- 130906 F-option with RF shielding available. Electrical specification simplified.
- 130607 Operational temperature range extended.
- 130405 Chapters *Specifications* and *Application* precised.
- 121001 Information about PWM and analog comparator added.
- 120831 Power consumption for OS v3.02D added.
- 120810 Electrical specification slightly precised. Some minor improvements.
- 120622 Block schematics and Table 6 added.
- 120518 Power consumption in Sleep updated. Version without serial EEPROM cancelled.
- 120425 RF range specified.
- 120322 Slightly improved. Fig. 4 added. Preliminary.
- 111011 Temperature sensor available optionally. Preliminary.
- 110919 Preliminary

---

# Sales and Service

---

## Corporate office

MICRORISC s.r.o., Prumyslova 1275, 506 01 Jicin, Czech Republic, EU  
Tel: +420 493 538 125, Fax: +420 493 538 126, [www.microrisc.com](http://www.microrisc.com)

## Partners and distribution

Please visit [www.iqrf.org/partners](http://www.iqrf.org/partners)

---

## Quality management

*ISO 9001 : 2009 certified*

*Complies with ETSI directives EN 301489-1 V1.9.2:2011, EN 301489-3 V1.6.1:2013, EN 300220-1 V2.4.1:2012, EN 300220-2 V2.4.1:2012 and VO-R/10/04.2012-7.*

*Complies with FCC directives Part 15 Low Power Communication Device Transmitter. FCC ID: R24TR-5XDX.*

*Complies with directives 2011/65/EU (RoHS) and 2012/19/EU (WEEE).*



## Trademarks

*The IQRF name and logo and MICRORISC name are registered trademarks of MICRORISC s.r.o. PIC, SPI, Microchip and all other trademarks mentioned herein are property of their respective owners.*

## Legal

*All information contained in this publication is intended through suggestion only and may be superseded by updates without prior notice. No representation or warranty is given and no liability is assumed by MICRORISC s.r.o. with respect to the accuracy or use of such information.*

*Without written permission it is not allowed to copy or reproduce this information, even partially.*

*No licenses are conveyed, implicitly or otherwise, under any intellectual property rights.*

*The IQRF® products utilize several patents (CZ, EU, US)*

---

**On-line support: [support@iqrf.org](mailto:support@iqrf.org)**

---



Smarter wireless. Simply.