

PRODUCT SPECIFICATION

TFT LCD MODULE

MODEL : KWH050ST19-F02 V.1 Version: 1.0

【 ◆ 】 Preliminary Specification

【 】 Finally Specification

CUSTOMER'S APPROVAL	
SIGNATURE:	DATA:

Designed by	R&D Checked by	Quality Department by	Approved by
LEO			

Prepared By :

FORMIKE ELECTRONIC CO.,LTD

Address : Flat 401-403, 4th Floor, Block B, iPARK Building, DengLiang Rd.,No.26, NanShan District, ShenZhen, 518054,China

TEL:(86) 755 88306921,88306931 FAX:(86) 755 88304615

Http:// www.wandisplay.com

● This specification is subject to change without notice. Please contact FORMIKE or it's representative before designing your product based on this specification.

Table Of Contents

List	Description	Page No.
0	Cover	1
0	Table Of Contents	2
1	Revision Record	3
2	General Description	4
3	External Dimensions	5
4	Interface Description	6
5	Absolute Maximum Ratings	7
6	Electrical Characteristics	7
7	Timing Characteristics	8
8	Backlight Characteristics	11
9	Optical Characteristics	12
10	Reliability Test Conditions And Methods	14
11	Inspection Standard	15
12	Handling Precautions	16
13	Precaution For Use	17

2. General Description

2.1 Description

KWH050ST19-F02 V.1 is a Transmissive type color active matrix liquid crystal display (LCD), which uses amorphous thin film transistor (TFT) as switching devices. This product is composed of a TFT LCD panel, driver IC, FPC ,TP and backlight unit . The following table described the features of FORMIKE KWH050ST19-F02 V.1.

2.2 Application

Mobile phone, Multimedia products
and other electronic Products
Etc.

2.3 Features:

Features	Description	UNITS
LCD type	5" TFT	--
Dot arrangement	800 (RGB) × 480	dots
Driver IC	OTA7001A and OTD9960A	--
Color Depth	16.7M	
Interface	24-Bit RGB Interface	--
View Direction	6 O'clock	--
Module size	120.9(W) × 75.95 (H) × 4.2(T)	mm
Active area	108.00(W) × 64.80(H)	mm
Dot pitch	0.135 (W) × 0.135 (H)	mm
Back Light	12 White LED In serial/parallel	--
With/Without TSP	With TSP	
Weight(g)	TBD	

3. External Dimensions

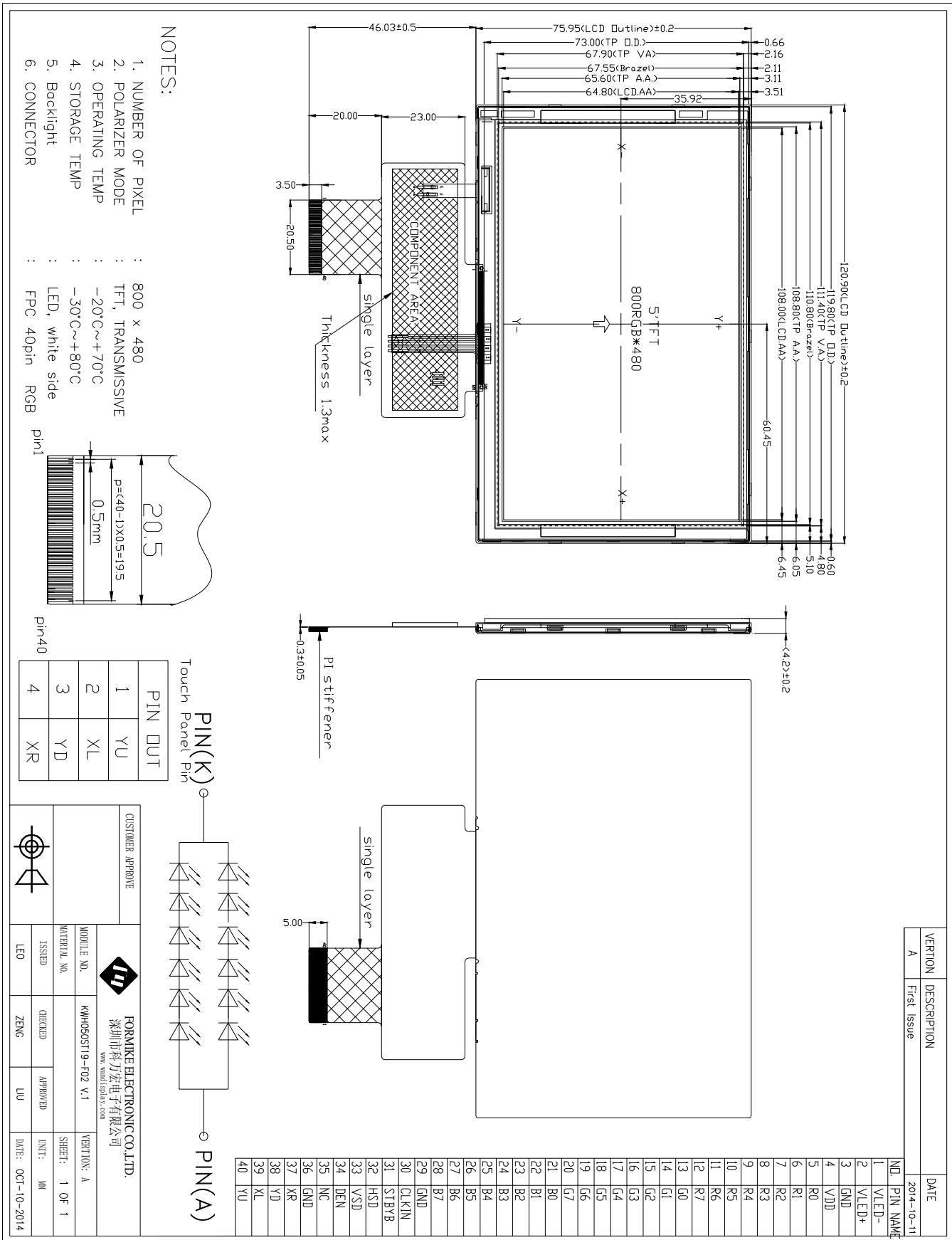

4. Interface Description

Pin No.	Symbol	Functional	Remark
1	VLED-	Power for LED backlight cathode.	
2	VLED+	Power for LED backlight anode.	
3	GND	Power ground.	
4	VDD	Power voltage.	
5	R0	Red data(LSB).	
6	R1	Red data.	
7	R2	Red data.	
8	R3	Red data.	
9	R4	Red data.	
10	R5	Red data.	
11	R6	Red data.	
12	R7	Red data(MSB).	
13	G0	Green data(LSB).	
14	G1	Green data.	
15	G2	Green data.	
16	G3	Green data.	
17	G4	Green data.	
18	G5	Green data.	
19	G6	Green data.	
20	G7	Green data(MSB).	
21	B0	Blue data(LSB).	
22	B1	Blue data.	
23	B2	Blue data.	
24	B3	Blue data.	
25	B4	Blue data.	
26	B5	Blue data.	
27	B6	Blue data.	
28	B7	Blue data(MSB).	
29	GND	Power Ground.	
30	CLKIN	Pixel clock.	
31	STBYB	Display on/off.	
32	HSD	Line synchronizing signal for RGB interface operation.	
33	VSD	Frame synchronizing signal for RGB interface operation.	
34	DE	Data Enable.	
35	NC	No Connector.	
36	GND	Power Ground.	
37	XR	Touch Panel Right Side Wire.	
38	YD	Touch Panel Down Side Wire.	
39	XL	Touch Panel Left Side Wire.	
40	YU	Touch Panel Up Side Wire.	

5. Absolute Maximum Ratings

Parameter	Symbol	Min	Max	Unit
Supply voltage for logic	V_{DD}	-0.3	5.0	V
Operating temperature	T_{OP}	-20	+70	°C
Storage temperature	T_{ST}	-30	+80	°C

6. Electrical Characteristics

Item	Symbol	Min	Typ	Max	Unit	Applicable terminal
Supply voltage for logic	V_{DD}	3.0	3.3	3.6	V	V_{DD}
Input voltage	V_{IL}	0	-	$0.3V_{DD}$	V	
	V_{IH}	$0.7 V_{DD}$	-	V_{DD}	V	

7. Timing Characteristics.

7.1 Block Diagram.

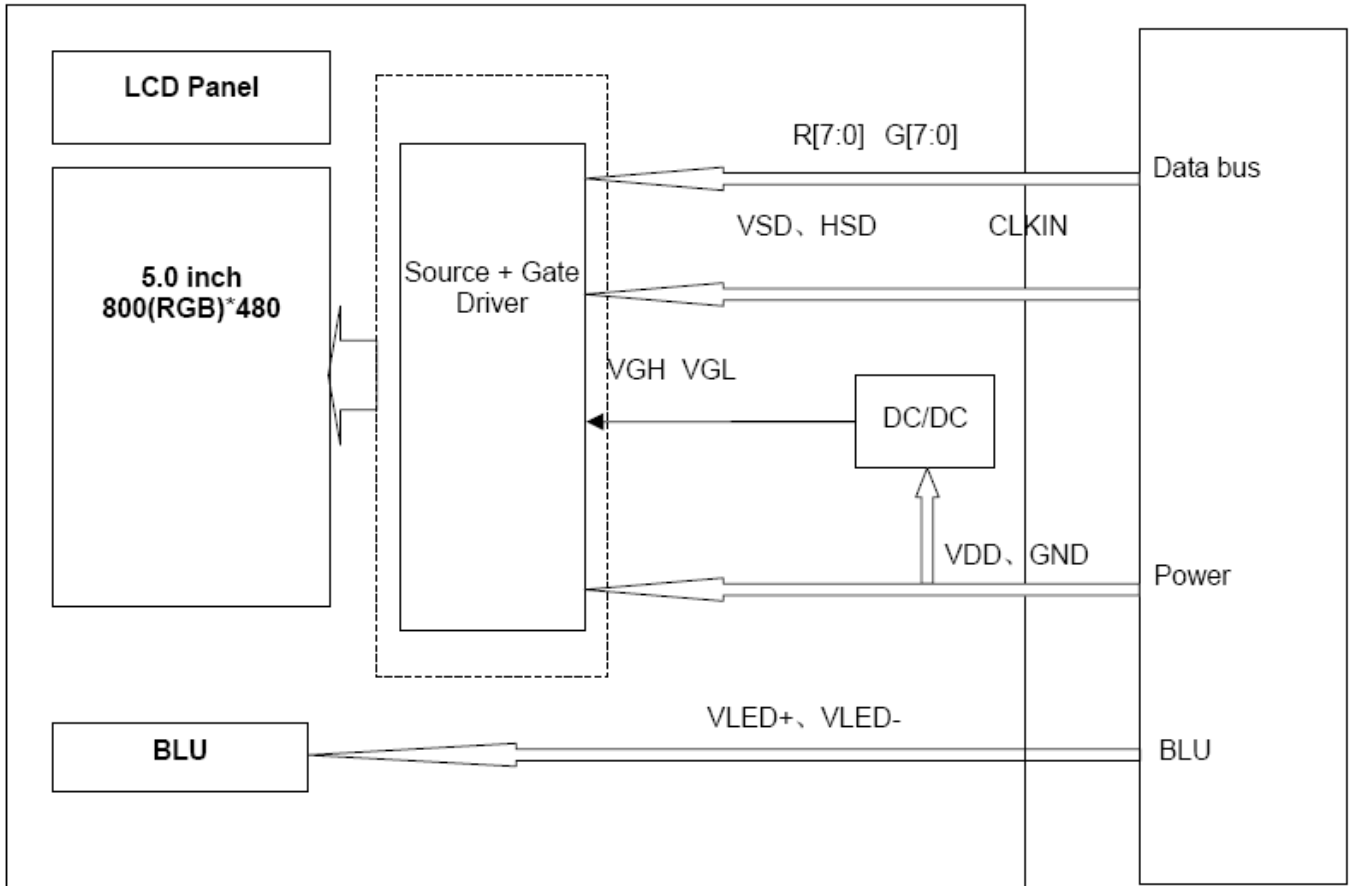

7.2 Input Clock And Data Timing

Parameter	Symbol	Min	Typ	Max	Unit	Remark
HSD Setup Time	T_{hst}	8			ns	
HSD Hold Time	T_{hhd}	8	-	-	ns	
VSD Setup Time	T_{vst}	8			ns	
VSD Hold Time	T_{vhd}	8	-	-	ns	
Data Setup Time	T_{dsu}	8			ns	
Data Hold Time	T_{dhd}	8	-	-	ns	
DE Setup Time	T_{esu}	8			ns	
DE Hold Time	T_{ehd}	8	-	-	ns	
CLKIN Cycle Time	T_{cph}	20	-	-	ns	
CLKIN Pulse Width	T_{cwh}	40	50	60	%	
Output stable time	T_{sst}	-	-	6	us	
VDD Power ON Slew rate	T_{por}			20	ms	
RSTB pulse width	TR_{st}	10	-	-	us	

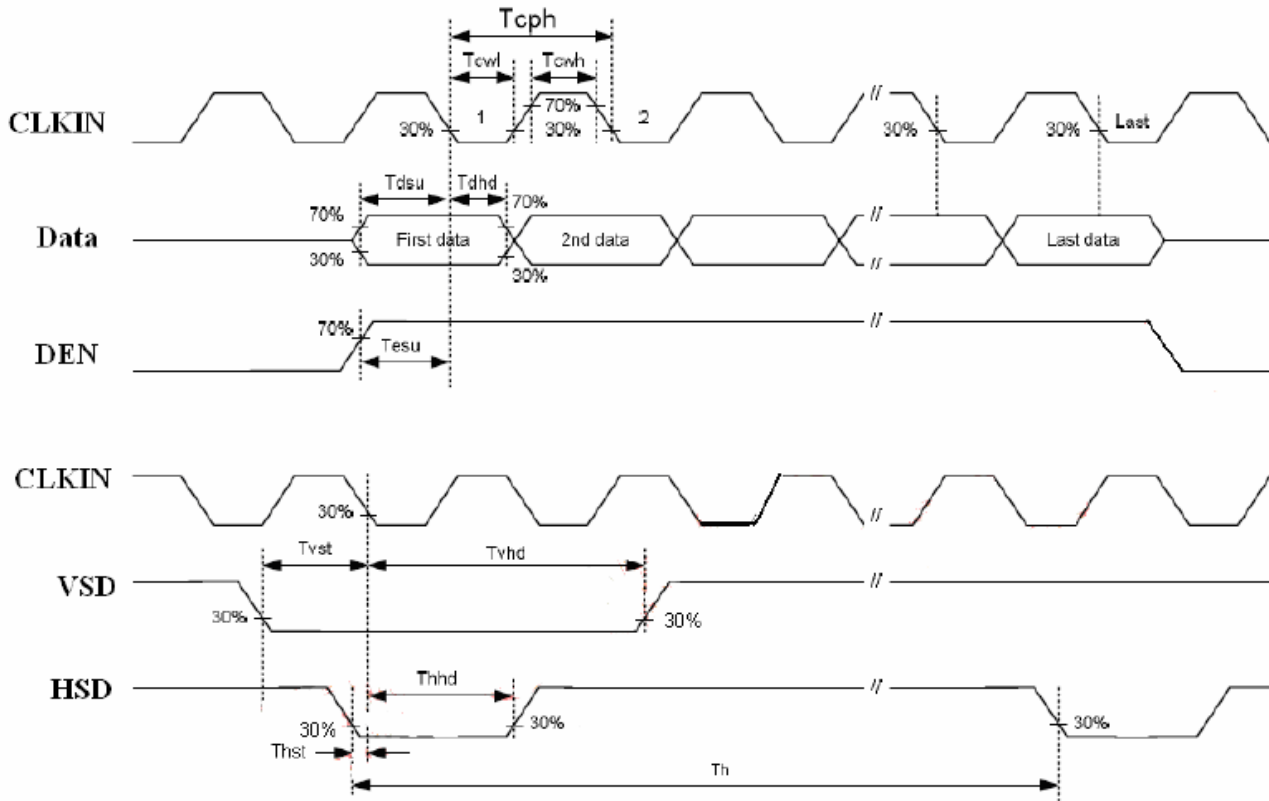

7.3 Parameter Setting Of Timing

Parameter	Symbol	Spec			Unit
		Min	Typ	Max	
Horizontal display area	t_{hd}		800		CLKIN
CLKIN frequency (60Hz)	f_{clk}	-	30	50	MHZ
One Horizontal Line	t_h	889	928	1143	CLKIN
HSD pulse width	t_{hpw}	1	48	255	CLKIN
HSD blanking	t_{hb}		88		CLKIN
HSD front porch	t_{hfp}	1	40	255	CLKIN
Vertical display area	t_{vd}		480		T_H
VSD period time	t_v	513	525	767	T_H
VSD pulse width	t_{vpw}	3	3	255	T_H
VSD Blanking(t_{vb})	t_{vb}		32		T_H
VSD Front porch (t_{vfp})	t_{vfp}	1	13	255	T_H

7.4 Horizontal Input Timing Diagram

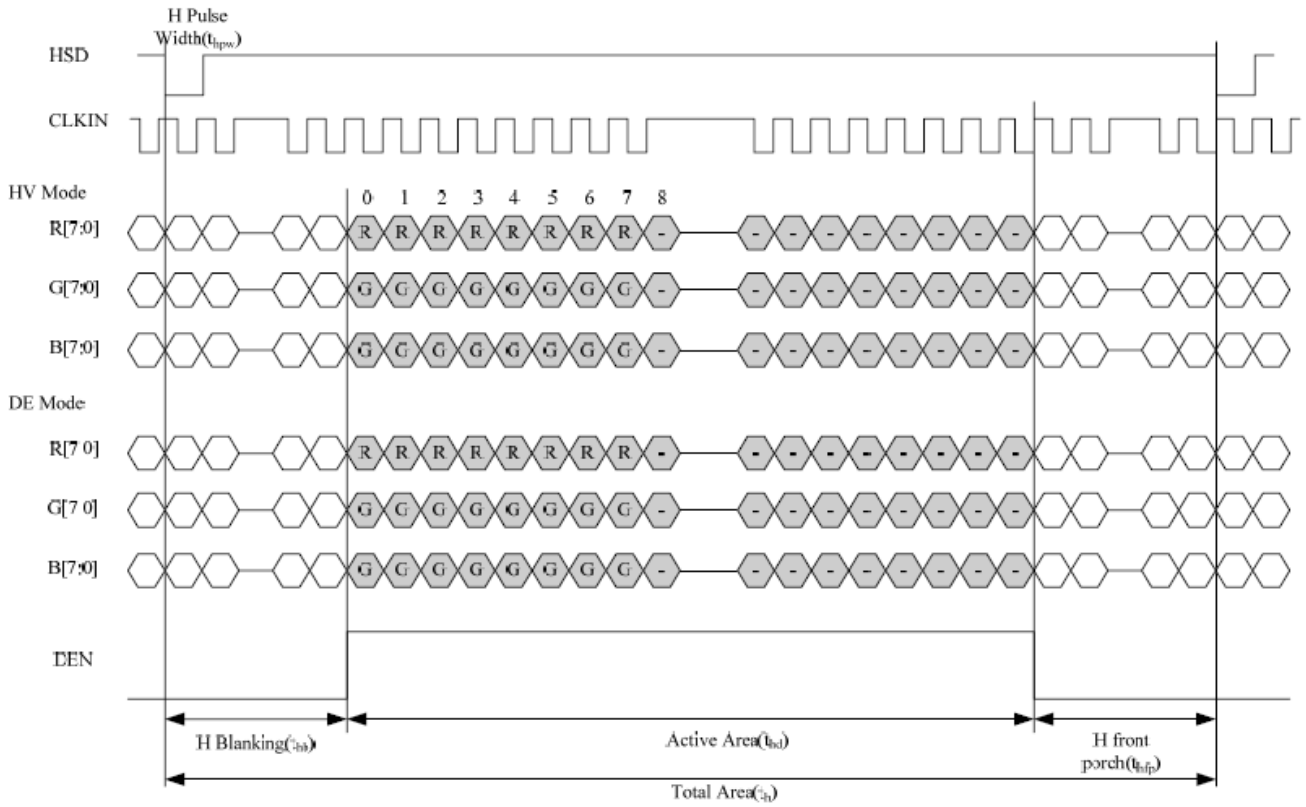

7.5 Vertical Input Timing Diagram

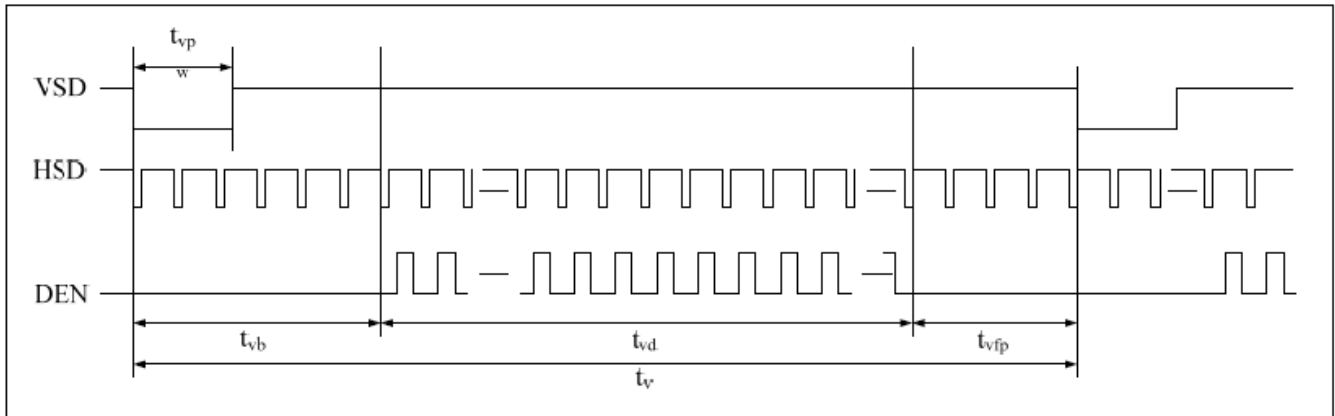

8. Backlight Characteristics.

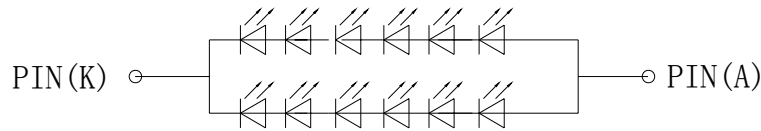

Item	Symbol	MIN	TYP	MAX	UNIT	Test Condition	Note
Supply Voltage	Vf	18	19.2	20.4	V	If=40 mA	-
Supply Current	If	-	40	-	mA	-	-
Reverse Voltage	Vr	-	-	5	V	10uA	
Power dissipation	Pd	-	768	-	mW	-	
Luminous Intensity for LCM		-	220	-	Cd/m²	If=40 mA	
Uniformity for LCM	-	80	-	-	%	If=40 mA	
Life Time	-	50000	-	-	Hr	If=40 mA	-
Backlight Color	White						

9.Optical Characteristics

ITEM	SYMBOL	CONDITION	MIN.	TYP.	MAX.	UNIT	REMARK
Transmittance	T		3.3	3.97		%	
Contrast Ratio	CR	*1)		350	-	--	Note 3
Response Time	Tr+ Tf	*3)	-	20		ms	Note 4
Viewing Angle	U	$\theta^{*2)}$	$CR \geq 10$	45	50	-	Note 5
	D			55	60	-	
	L	$\psi^{*2)}$		60	65	-	
	R			60	65	-	
Color Filter Chromaticity	White	x y Y	$\theta = \phi = 0^\circ$	0.297	0.317	0.337	Note 6
				0.304	0.324	0.344	
				27.5	30.5	33.5	
	Red	x y Y	$\theta = \phi = 0^\circ$	0.613	0.633	0.653	
				0.321	0.341	0.361	
				18.3	21.3	24.3	
	Green	x y Y	$\theta = \phi = 0^\circ$	0.304	0.324	0.344	
				0.531	0.551	0.571	
				48.4	52.4	56.4	
	Blue	x y Y	$\theta = \phi = 0^\circ$	0.133	0.153	0.173	
				0.123	0.143	0.163	
				14.8	17.8	20.8	
NTSC			-	50%	-		

Note 1.Ambient condition : $25^\circ\text{C} \pm 2^\circ\text{C}$, $60 \pm 10\% \text{RH}$, under 10 Lux in the darkroom .

Note 2.Measure device : BM-5A (TOPCON) , viewing cone= 1° , $I_L=20\text{mA}$.

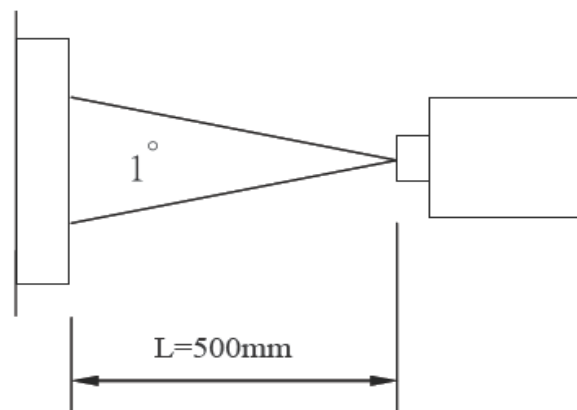

Note 3. Definition of Contrast Ratio :

$$CR = \text{White Luminance (ON)} / \text{Black Luminance (OFF)}$$

Note 4. Definition of response time : The response time is defined as the time interval between the 10% and 90% amplitudes.

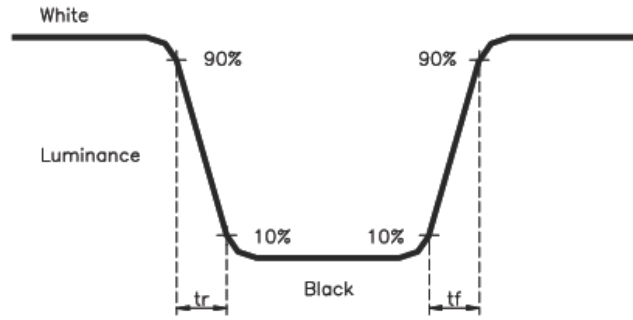

Note 5. Definition of view angle(θ , ψ) :

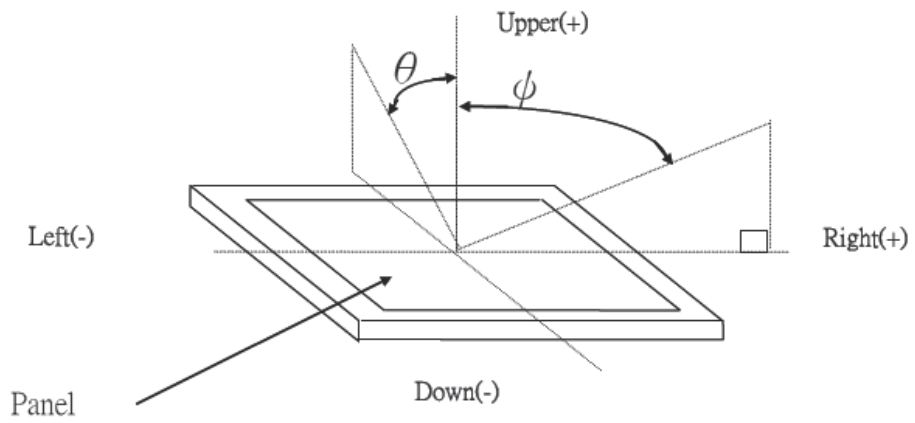

Note 6. Light source: C light.

10. Reliability Test Conditions And Methods

NO.	TEST ITEMS	TEST CONDITION	INSPECTION AFTER TEST
①	High Temperature Storage	80°C ± 2°C × 200Hours	Inspection after 2~4hours storage at room temperature, the samples should be free from defects: 1,Air bubble in the LCD. 2,Sealleak. 3,Non-display. 4,Missing segments. 5,Glass crack. 6,Current IDD is twice higher than initial value. 7, The surface shall be free from damage. 8, The electric Characteristics requirements shall be satisfied.
②	Low Temperature Storage	- 30°C ± 2°C × 200Hours	
③	High Temperature Operating	70°C ± 2°C × 120Hours	
④	Low Temperature Operating	- 20°C ± 2°C / 120Hours	
⑤	Temperature Cycle(Storage)	- 30°C ± 2°C ↔ 25°C 80°C ± 2°C (30min) (5min) (30min) ←————→ 1cycle Total 10cycle	
⑥	Damp Proof Test	50°C ± 5°C × 90%RH × 120Hours	
⑦	Vibration Test	Frequency:10Hz~55Hz~10Hz Amplitude:1.5M X,Y,Z direction for total 3hours (Packing Condition)	
⑧	Drooping Test	Drop to the ground from 1M height one time every side of carton. (Packing Condition)	
⑨	ESD Test	Voltage: ± 8KV, R:330 Ω, C:150PF, Air Mode, 10times	

REMARK:

- 1,The Test samples should be applied to only one test item.
- 2,Sample side for each test item is 5~10pcs.
- 3,For Damp Proof Test,Pure water(Resistance>10MΩ) should be used.
- 4, In case of malfunction defect caused by ESD damage, if it would be recovered to normal state after resetting, it would be judge as a good part.
- 5,EL evaluation should be excepted from reliability test with humidity and temperature: Some defects such as black spot/blemish can happen by natural chemical reaction with humidity and Fluorescence EL has.
- 6, Failure Judgment Criterion: Basic Specification Electrical Characteristic, Mechanical Characteristic, Optical Characteristic.

11. Inspection Standard

This standard apply to TFT module specification.

1. Inspection condition:

Under daylight lamp 20~40W, product distance inspector'eye 30cm, incline degree 30° .

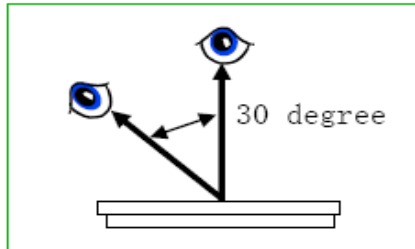

2. Inspection standard

NO.	Item	Inspection standard	Rate															
2.1	Dot	<p>Case of Dot defect is below</p> <p>① Bright Dot (whit spot) : "0"</p> <p>② Dark Dot (black spot) : "0" (In case of Dark Dot on Main TFT LCD)</p> <p>- NG if there's full Dot defect.</p> <p>- Damaged less than the size of sub-pixel is not counted as defect</p> <p>- Dots darker than the size of sub-pixel are not defined as bright dot defect</p>	minor															
		<table border="1"> <thead> <tr> <th>area size (mm)</th> <th>Acceptable number</th> </tr> </thead> <tbody> <tr> <td>$\Phi \leq 0.10$</td> <td>ignore</td> </tr> <tr> <td>$0.10 < \Phi \leq 0.15$</td> <td>3</td> </tr> <tr> <td>$0.15 < \Phi \leq 0.20$</td> <td>2</td> </tr> <tr> <td>$0.25 < \Phi \leq 0.25$</td> <td>1</td> </tr> <tr> <td>$0.25 < \Phi$</td> <td>0</td> </tr> </tbody> </table>		area size (mm)	Acceptable number	$\Phi \leq 0.10$	ignore	$0.10 < \Phi \leq 0.15$	3	$0.15 < \Phi \leq 0.20$	2	$0.25 < \Phi \leq 0.25$	1	$0.25 < \Phi$	0			
		area size (mm)		Acceptable number														
		$\Phi \leq 0.10$		ignore														
		$0.10 < \Phi \leq 0.15$		3														
		$0.15 < \Phi \leq 0.20$		2														
$0.25 < \Phi \leq 0.25$	1																	
$0.25 < \Phi$	0																	
2.2	line	<table border="1"> <thead> <tr> <th colspan="2">Size (mm)</th> <th>Acceptable number</th> </tr> </thead> <tbody> <tr> <td>ignore</td> <td>$W \leq 0.03$</td> <td>ignore</td> </tr> <tr> <td>$L \leq 4.0$</td> <td>$0.03 < W \leq 0.04$</td> <td>2</td> </tr> <tr> <td>$L \leq 4.0$</td> <td>$0.04 < W \leq 0.05$</td> <td>1</td> </tr> <tr> <td></td> <td>$0.05 < W$</td> <td>Treat with dot non-conformance</td> </tr> </tbody> </table>	Size (mm)		Acceptable number	ignore	$W \leq 0.03$	ignore	$L \leq 4.0$	$0.03 < W \leq 0.04$	2	$L \leq 4.0$	$0.04 < W \leq 0.05$	1		$0.05 < W$	Treat with dot non-conformance	
		Size (mm)		Acceptable number														
		ignore	$W \leq 0.03$	ignore														
		$L \leq 4.0$	$0.03 < W \leq 0.04$	2														
		$L \leq 4.0$	$0.04 < W \leq 0.05$	1														
	$0.05 < W$	Treat with dot non-conformance																

12. Handling Precautions

12.1 Mounting method

The LCD panel of FORMIKE ELECTRONIC CO.,LTD. module consists of two thin glass plates with polarizes which easily be damaged. And since the module in so constructed as to be fixed by utilizing fitting holes in the printed circuit board.

Extreme care should be needed when handling the LCD modules.

12.2 Caution of LCD handling and cleaning

When cleaning the display surface, Use soft cloth with solvent

[recommended below] and wipe lightly

- Isopropyl alcohol
- Ethyl alcohol

Do not wipe the display surface with dry or hard materials that will damage the polarizer surface.

Do not use the following solvent:

- Water
- Aromatics

Do not wipe ITO pad area with the dry or hard materials that will damage the ITO patterns

Do not use the following solvent on the pad or prevent it from being contaminated:

- Soldering flux
- Chlorine (Cl) , Salfur (S)

If goods were sent without being sili8con coated on the pad, ITO patterns could be damaged due to the corrosion as time goes on.

If ITO corrosion happen by miss-handling or using some materials such as Chlorine (Cl), Salfur (S) from customer, Responsibility is on customer.

12.3 Caution against static charge

The LCD module use C-MOS LSI drivers, so we recommended that you:

Connect any unused input terminal to Vdd or Vss, do not input any signals before power is turned on, and ground your body, work/assembly areas, assembly equipment to protect against static electricity.

12.4 packing

- Module employ LCD elements and must be treated as such.
- Avoid intense shock and falls from a height.
- To prevent modules from degradation, do not operate or store them exposed direct to sunshine or high temperature/humidity

12.5 Caution for operation

- It is an indispensable condition to drive LCD's within the specified voltage limit since the higher voltage then the limit cause the shorter LCD life.
- An electrochemical reaction due to direct current causes LCD's undesirable deterioration, so that the use of direct current drive should be avoided.
- Response time will be extremely delayed at lower temperature then the operating temperature range and on the other hand at higher temperature LCD's how dark color in them. However those phenomena do not mean malfunction or out of order with LCD's, which will come back in the specified operation temperature.
- If the display area is pushed hard during operation, some font will be abnormally displayed but it resumes normal condition after turning off once.
- A slight dew depositing on terminals is a cause for electro-chemical reaction resulting in terminal open circuit. Usage under the maximum operating temperature, 50%Rh or less is required.

12.6 storage

In the case of storing for a long period of time for instance, for years for the purpose or replacement use, the following ways are recommended.

- Storage in a polyethylene bag with the opening sealed so as not to enter fresh air outside in it . And with no desiccant.
- Placing in a dark place where neither exposure to direct sunlight nor light's keeping the storage temperature range.
- Storing with no touch on polarizer surface by the anything else.
It is recommended to store them as they have been contained in the inner container at the time of delivery from us

12.7 Safety

- It is recommendable to crash damaged or unnecessary LCD's into pieces and wash off liquid crystal by either of solvents such as acetone and ethanol, which should be burned up later.
- When any liquid leaked out of a damaged glass cell comes in contact with your hands, please wash it off well with soap and water

13. Precaution For Use

13.1

A limit sample should be provided by the both parties on an occasion when the both parties agreed its necessity. Judgment by a limit sample shall take effect after the limit sample has been established and confirmed by the both parties.

13.2

On the following occasions, the handing of problem should be decided through discussion and agreement between responsible of the both parties.

- When a question is arisen in this specification
- When a new problem is arisen which is not specified in this specifications
- When an inspection specifications change or operating condition change in customer is reported to FORMIKE ELECTRONIC CO.,LTD,and some problem is arisen in this specification due to the change
- When a new problem is arisen at the customer's operating set for sample evaluation in the customer site.