



Corp. Automotive Components Gr.

THE NEW VALUE FRONTIER



A KYOCERA GROUP COMPANY

PBRC-MR Series

11th Dec. 2015

KYOCERA Corporation
Automotive Components
Engineering division
Engineering section

京セラ株式会社

1. Series Name

PBRC-MR series

(+85deg.C / consumer/industrial / 4.5 x 2.0 mm)

2. Electrical Characteristics

(key parameters)

PN	Freq	Freq Initial Tolerance	Freq Temp Stability	Resonant Impedance
	(MHz)	(%)	(%)	ohm
PBRC4.00MR50X000	4.00	±0.5	±0.5	60
PBRC4.19MR50X000	4.19	±0.5	±0.5	60
PBRC4.91MR50X000	4.91	±0.5	±0.5	60
PBRC5.00MR50X000	5.00	±0.5	±0.5	60
PBRC6.00MR50X000	6.00	±0.5	±0.5	60
PBRC7.37MR50X000	7.37	±0.5	±0.5	60
PBRC8.00MR50X000	8.00	±0.5	±0.5	60
PBRC10.00MR50X000	10.00	±0.5	±0.5	70
PBRC12.00MR50X000	12.00	±0.5	±0.5	70
PBRC16.00MR50X000	16.00	±0.5	±0.5	70

PN	Freq	Freq Initial Tolerance	Freq Temp Stability	Resonant Impedance
	(MHz)	(%)	(%)	ohm
PBRC20.00MR50X000	20.00	±0.5	±0.5	70
PBRC4.00MR10X000	4.00	±0.1	±0.2	60
PBRC8.00MR10X000	8.00	±0.1	±0.2	60

(other common parameters)

Items	Specifications
Standard Test IC	MC14069UB(4.0-8.0MHz) / MC74HCU04(8.01-20.0mHz) (Freescale)
Withstanding Voltage	100 V D.C. 10 sec max.
Max. Input Signal Voltage	15 Vp-p
Insulation Resistance	100 M Ω min. (at 10 V D.C.)
Operating Temperature Range	-40 to +85°C
Storage Temperature Range	-40 to +85°C
Aging for 10 years on Oscillating Frequency	fosc \pm 0.05 / \pm 0.30 % max. (at 25°C from initial value)

3-1. Measurement Condition

The reference temperature shall be 25 ± 2 °C.
 The measurement shall be performed in the temperature range from 15 to 35°C unless otherwise the result is doubtful.

3-2. Measurement Circuit

Oscillating frequency shall be measured using the Kyocera standard test circuit shown in Fig. 1.

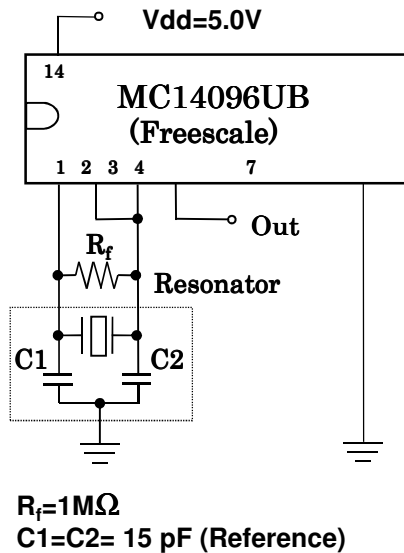
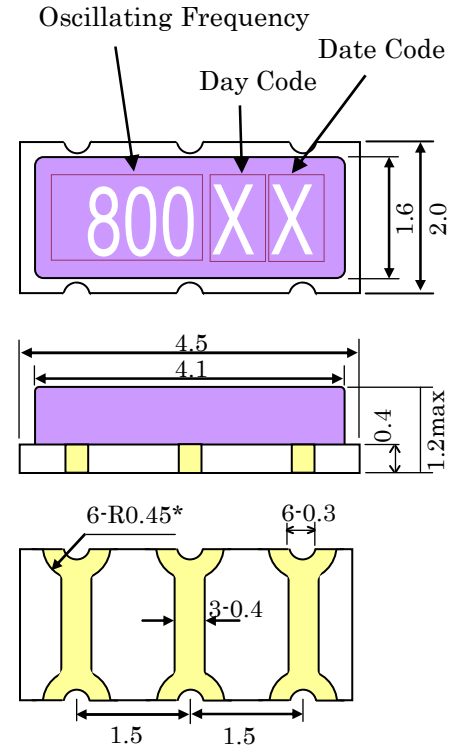

Fig.1 Standard Measuring Circuits

4. Dimensions



Unit: mm
 Tol.: ± 0.2 mm (* ± 0.1 mm)
 Terminal: Au flashed nickel barrier

Oscillating Frequency

Ex.8.00 (8.00 is the meaning of 8.00MHz/Oscillating Frequency)

Date Code

Jan. to Dec. 2013: A to M (except "I")
 Jan. to Dec. 2014: N to Z (except "O")
 Jan. to Dec. 2015: a to m (except "i")
 Jan. to Dec. 2016: n to z (except "o")

Note:

These alphabets should be after Jan.2017.

5. Recommended Land Pattern

Unit: mm

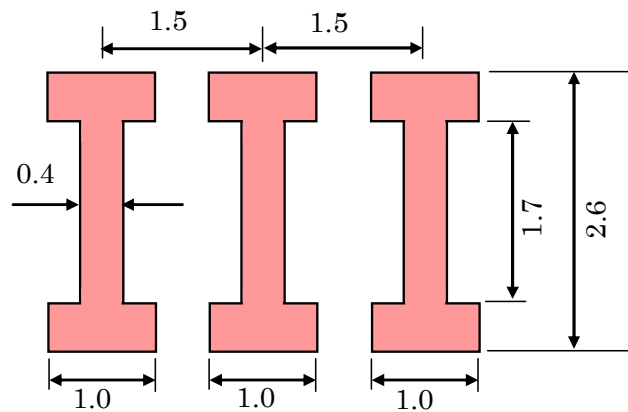

6. Recommended IR Reflow Profile

