

A33-OLinuXino, hardware revision B1

www.OLIMEX.com

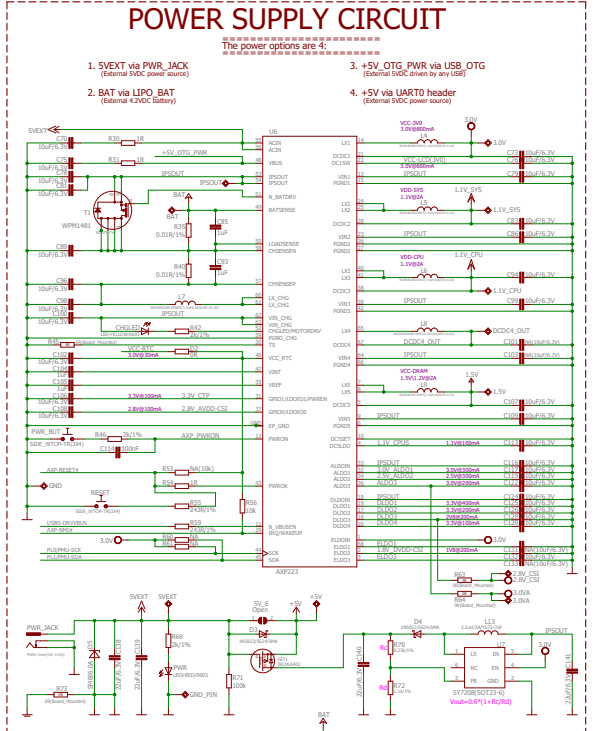

This hardware design by Olimex LTD is licensed under a Creative Commons Attribution-ShareAlike 3.0 Unported License.

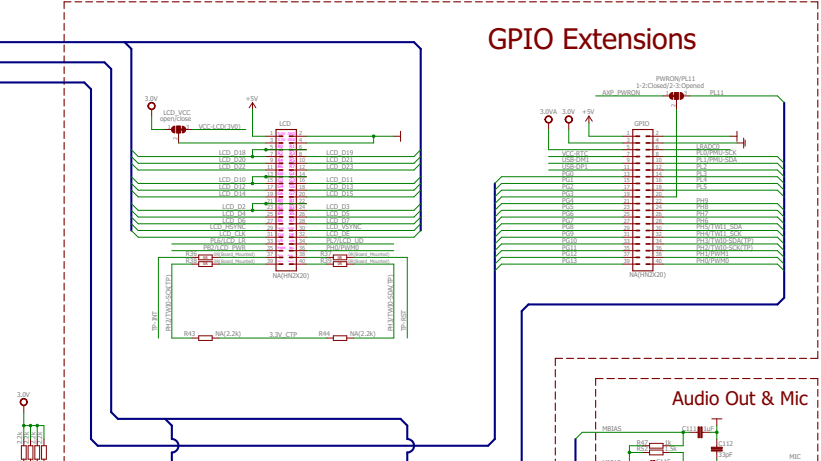
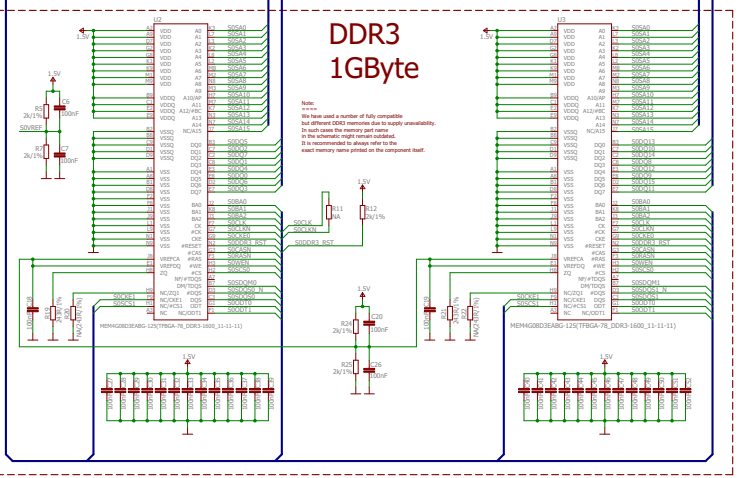
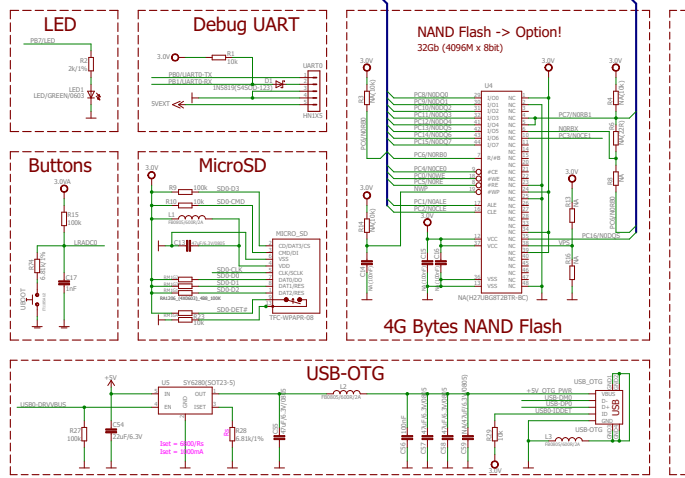

This hardware design by Olimex LTD is licensed under a Creative Commons Attribution-ShareAlike 3.0 Unported License.

A33-OLinuXino, hardware revision B1

www.OLIMEX.com