

RC-04D-7

IQRF Programmable remote controller

User's Guide



Description

RC-04D-7 is a universal user programmable IQRF remote controller with bidirectional communication.

It is a generic equipment, i.e. the hardware is fixed and the user can implement specific functionality by software for internal microcontroller. The code can be uploaded wirelessly.



Key features

- IQRF transceiver DCTR-76D inside
- Programmable via RF
- On-board PCB antenna
- 4 pushbuttons, 2 LEDs
- Bidirectional communication providing high security in comparison to unidirectional systems
- Sleep mode with ultra low power consumption
- Coin battery

Applications

- Portable controller
- Any systems with IQRF connectivity
- Wide usage facilities

Simplified schematic

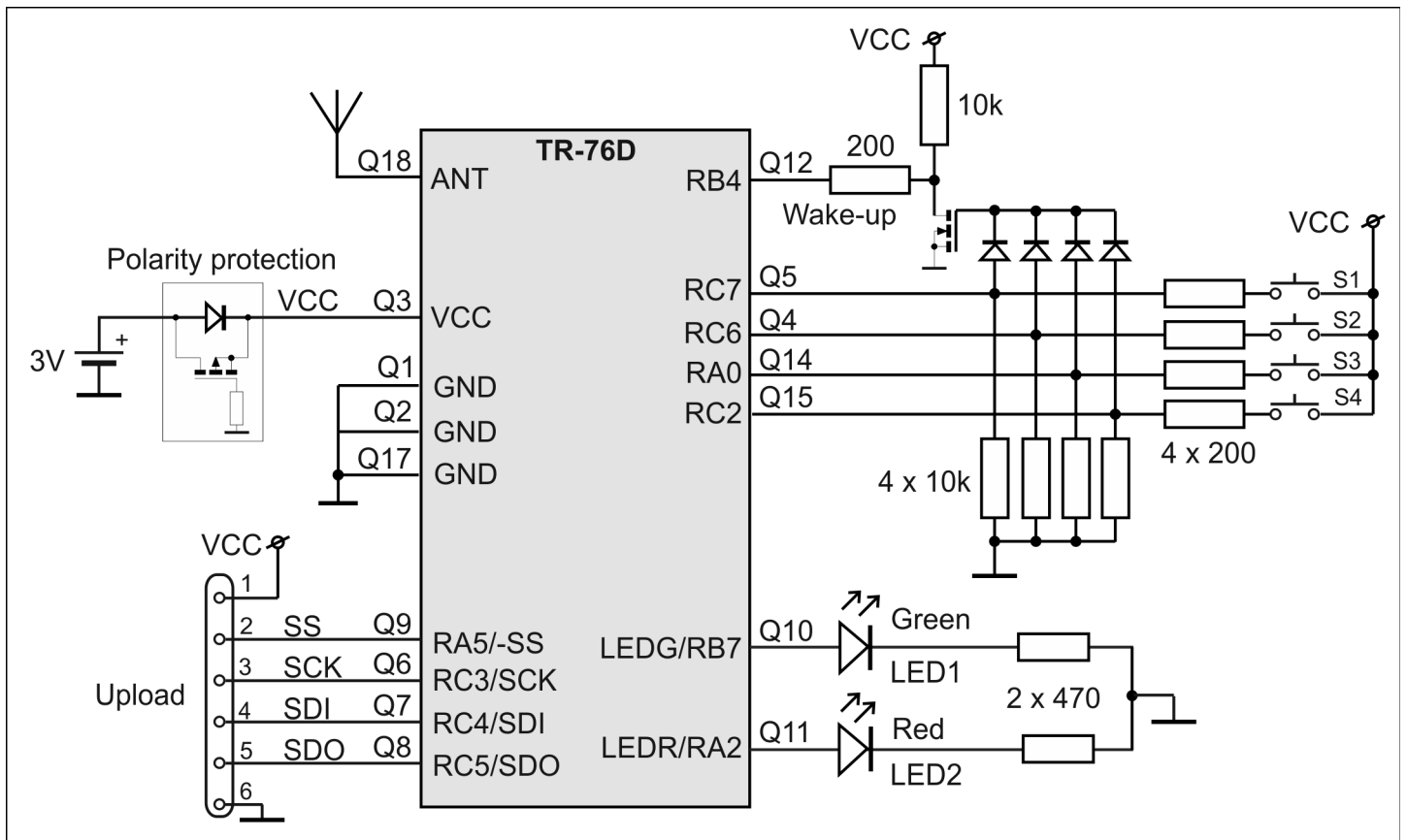

Electrical specifications	Typical values unless otherwise stated
RF transceiver	DCTR-76D
Antenna	PCB shortened ¼ wave whip
RF band	868 MHz or 916 MHz, multiple channels (SW selectable)
RF output power	Up to 11 dBm, programmable in 8 levels
Battery	Lithium 3V, 210 mAh coin cell CR2032
Supply current	<i>Depends on application SW (see TR-76D datasheet for details)</i>
Sleep mode	< 1 µA (all peripherals shut down)
Run mode	
RF sleep	1.6 mA
RF ready	3.0 mA
Additional supply current	2 mA (one LED on), 4 mA (two LEDs on)
RX mode	
STD	12.3 mA
LP	233 µA (depends on interferences)
XLP	15 µA (depends on interferences)
TX mode	8.3 mA – 19 mA (according to RF output power)
RF range	Up to 320 m (in free space)
Operating temperature	-20 °C to +40 °C, with respect to the battery operating conditions
Dimensions	58 mm x 42 mm x 14 mm
Weight	29 g (with the battery and the charm chain)

Absolute maximum ratings

Stresses above those values may cause permanent damage to the device. Exposure to maximum rating conditions for extended periods may affect device reliability.

Supply voltage (VCC)	3.5 V
Storage temperature	-20 °C to +85 °C, with respect to the battery storing conditions

Hardware

RC-04D-7 is a generic equipment, i.e. the hardware is fixed and specific functionality can be implemented by software for integrated transceiver module.

Power supply

RC-04D-7 is supplied from the coin non-rechargeable battery.

Sleep mode

It is possible to switch off all functions and peripherals to minimize current. For Sleep mode control refer to demo software included. The power can not be switched off at all (unless removing the battery), the Sleep mode should be used instead of this.

Tip: User SW should allow wake-up the controller after a pushbutton(s) press. See demo SW included.

Pushbuttons and LEDs

Functionality of all four pushbuttons and both LEDs is fully under control of application software.

RF transceiver

IQRF wireless transceiver TR-76D.

- Uploading of application code is possible via IQRF wireless upload.
- Pads for wired upload via SPI accessible on the PCB board are intended for troubleshooting only. See the silkscreen on the PCB for pinout description.
 - Using the CK-USB-04A programmer: See the CK-USB-04A User's guide.
 - Using the CK-USB-04 programmer and the KON-TR-01P adapter. See the KON-TR-01P User's guide.

Antenna

Built-in PCB antenna on the RC-04D-7 board.

Software

Demo application

This demo illustrates unidirectional non-networking communication between the RC-04D-7 controller and the CK-USB-04(A) kit equipped with the TR-72DA module connected to PC with the IQRF IDE Terminal running. The RC04D-7_demo.c program is intended for the controller and the E02-RX (one of basic IQRF examples) for the TR module in the CK kit. They are available to download on RC-04D-7 product page and in IQRF Startup package, respectively. To upload the RC04-7_demo.hex to the RC-04D-7 via RF, see the IQRF OS User's guide, Appendix RFPGM. Switching to RFPGM mode after reset is enabled by default.

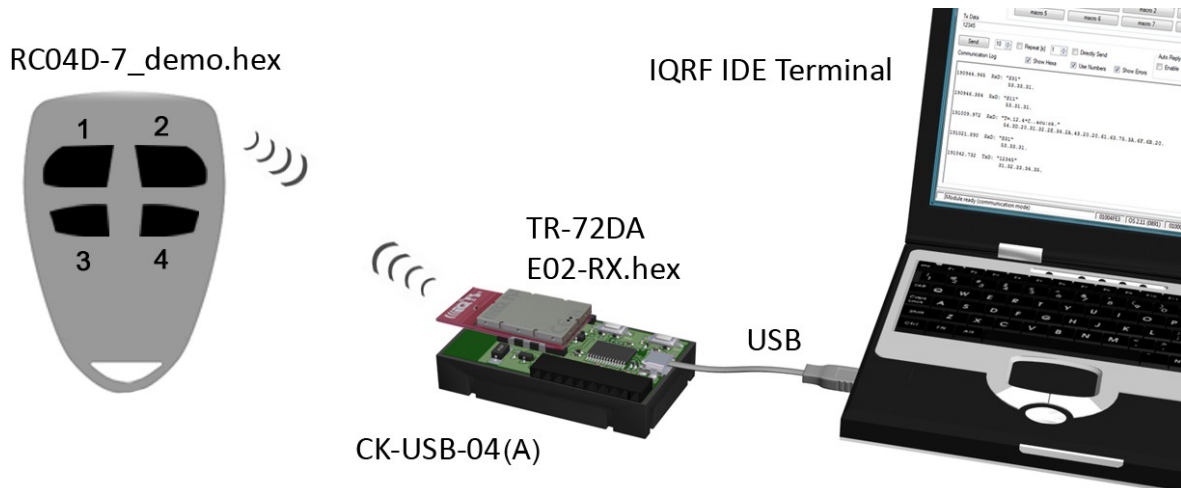

In idle state the controller stays in Sleep mode allowing wake-up by any pushbutton. After wake-up the battery voltage is checked and LEDs flashing indicates pressing the button and accumulator condition. Then respective command is sent to CK-USB-04(A) and the controller gets to sleep again.

Buttons	Function	
• S1	Text sent: "S1x"	x=0 if battery O.K., otherwise x=1
• S2	Text sent: "S2x"	..
• S3	Text sent: "S3x"	..
• S4	Text sent: "S4x"	..
• S3 and S4 for more than 5 s	Enter RFPGM mode	
• Any button for more than 0.7 s	Leave RFPGM mode	

LED indication	
• Button S1 to S4	1 x flash green (battery O.K.) / red (battery exhausted).
• RFPGM indication	See the IQRF OS User's guide, Appendix RFPGM, indication in RFPGM LP mode.

Caution: Demo software version should correspond to IQRF OS version implemented in RC-04D-7.

To read out the OS version, catch Module Info which is always sent by this Demo application just before switching to RFPGM mode in IQRF IDE Terminal. The *Show hexa* checkbox should be activated for this. OS version is stored in buffer `moduleINFO[4]`. See the picture above and IQRF OS User's guide.

Example:

```
moduleINFO[0-7]:
 [0] [1] [2] [3] [4] [5] [6] [7]
 B9 8D 00 81 38 B4 79 08
```

`moduleINFO[4] = 38` means OS v3.08D

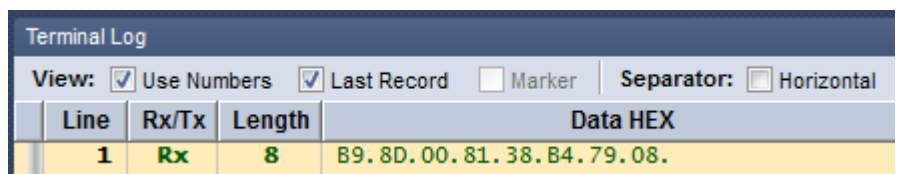

Caution

The only standard way how to upload user application into the RC-04D-7 is RFPGM (in-circuit wireless programming). Demo application `RC04D-7_demo.c` invokes the `enableRFPGM` function first. It ensures that after every reset (due to reconnecting the battery) the device is switched to RFPGM mode and can possibly be reprogrammed. This feature can be removed (by `disableRFPGM`), but it should not be done unless there is another reliable way how to invoke back the RFPGM mode using `runRFPGM` after pressing a pushbutton. See the demo application, refer to the IQRF OS User's guide, Appendix RFPGM for details. **If being omitted, the device can not be reprogrammed wirelessly any more. Recovery is possible by wired upload using the PCB pads inside the case only.**

Tip: Always use `enableRFPGM` during development.

Product information

Pack list

- RC-04D-7 remote controller with charm chain, battery inserted, the `RC04D-7_demo` demo uploaded, in Sleep mode

Recommended options

- CK-USB-04(A) Programmer / development kit for wireless upload (RFPGM)
- TR-72DA Additional TR module for the CK-USB-04(A) for wireless upload (RFPGM)
- CAB-USBABMICRO USB cable to connect CK-USB-04(A) to PC
- GW-USB-06 Complete comfortable RFPGM programmer (alternative to all above)

Ordering code

- RC-04D-7 RC-04D-7 Remote controller

Document history

- 160401 First release

Sales and Service

Corporate office

MICRORISC s.r.o., Prumyslova 1275, 506 01 Jicin, Czech Republic, EU
Tel: +420 493 538 125, Fax: +420 493 538 126, www.microrisc.com

Partners and distribution

Please visit www.iqrf.org/partners.

Quality management

ISO 9001 : 2009 certified

Complies with ETSI directives EN 301489-1 V1.9.2:2011, EN 301489-3 V1.6.1:2013, EN 300220-1 V2.4.1:2012, EN 300220-2 V2.4.1:2012 and VO-R/10/05.2014-3.

Complies with directives 2011/65/EU (RoHS) and 2012/19/EU (WEEE).



Trademarks

The IQRF name and logo and MICRORISC name are registered trademarks of MICRORISC s.r.o. PIC, SPI, Microchip and all other trademarks mentioned herein are property of their respective owners.

Legal

All information contained in this publication is intended through suggestion only and may be superseded by updates without prior notice. No representation or warranty is given and no liability is assumed by MICRORISC s.r.o. with respect to the accuracy or use of such information.

Without written permission it is not allowed to copy or reproduce this information, even partially.

No licenses are conveyed, implicitly or otherwise, under any intellectual property rights.

The IQRF® products utilize several patents (CZ, EU, US)

On-line support: support@iqrf.org



Smarter wireless. Simply.