

REV.	DESCRIPTION	DRAWN	DATE
1	INITIAL RELEASE	FROS	2015/12/11

SPECIFICATION:

1. ELECTRICAL
 - 1.1 Current Rating: 1A
 - 1.2 Voltage Rating: 12V
 - 1.3 Contact Resistance: 50mΩ MAX. at Working Height
2. MECHANICAL
 - 2.1 Durability: 10,000 Cycle
 - 2.2 Spring Force: 110g±20% at Working Height
3. To avoid arcing issue, The adaptor start to power supply after connector mated fully.
4. To ensure the best usage, please operate it based on the working height
5. Based on the Drawing, shall not exceed the maximum allowed compress.

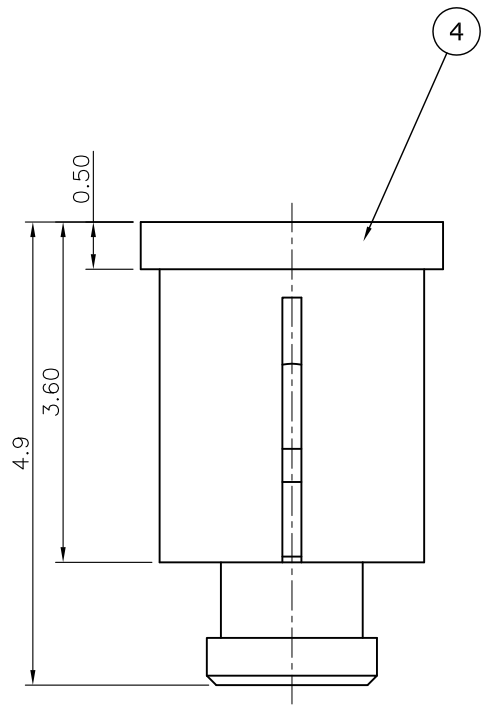

Pogo Pin with Cap

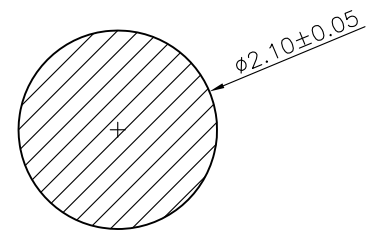
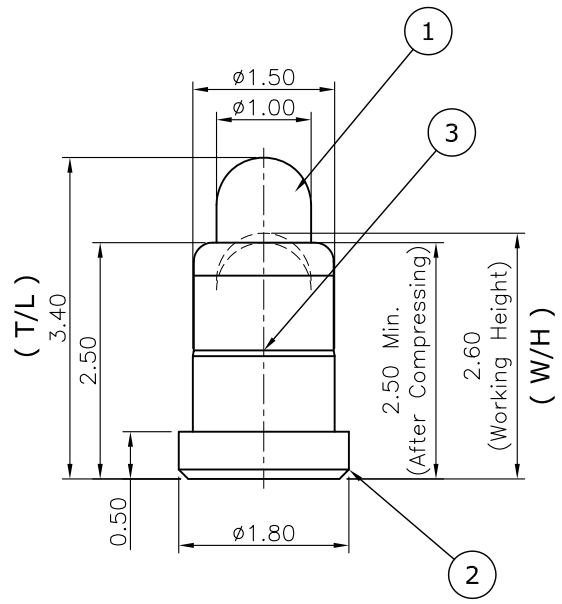

RECOMMENDED LAYOUT

4	CAP	HTN UL94V-0, BLACK
3	SPRING	STAINLESS STEEL SUS304
2	BARREL	BRASS C3604, 10U" GOLD 50U" NICKEL UNDER PLATED
1	PISTON	BRASS C3604, 10U" GOLD ON CONTACT AREA 50U" NICKEL UNDER PLATED

NO.	PART NAME	DESCRIPTION		
UNLESS OTHERWISE SPECIFIED TOLERANCE				
UNIT:	DECIMAL	LINEAR	ANGLES	
mm	X.			
	X.X	±0.20	±5°	
	X.XX	±0.10	±2°	
DRAWN	Fros	2015/12/11	DRAWN NAME: Pogo Pin Flat Type, 1Pin, T/L 3.4mm, W/H 2.6mm, Reel	
CHECKED	Amy	2015/12/11		
APPROVED	Ken	2015/12/11		
SCALE		SHEET	SIZE	FILE NAME
12.5		1/1	A4	303A-250918-002_B_1



WWW.ATTEND.COM.TW