

JCB Series



- 2:1 Input Range
- Operating Temperature $-40\text{ }^{\circ}\text{C}$ to $+100\text{ }^{\circ}\text{C}$
- Single & Dual Outputs
- 1500 VDC Isolation
- Optional Isolation to 3000 VDC
- Optional Metal Case
- 3 Year Warranty

Specification

Input

Input Voltage Range	<ul style="list-style-type: none"> • 5 V (4.5-9 VDC) • 12 V (9-18 VDC) • 24 V (18-36 VDC) • 48 V (36-72 VDC)
Input Current	<ul style="list-style-type: none"> • See table
Input Filter	<ul style="list-style-type: none"> • Pi network
Input Reflected Ripple	<ul style="list-style-type: none"> • 35 mA pk-pk through 12 μH inductor
Input Surge	<ul style="list-style-type: none"> • 5 V models 15 VDC for 100 ms • 12 V models 24 VDC for 100 ms • 24 V models 40 VDC for 100 ms • 48 V models 80 VDC for 100 ms
Undervoltage Lockout	<ul style="list-style-type: none"> • None
Reverse Voltage Protection	<ul style="list-style-type: none"> • None

Output

Output Voltage	<ul style="list-style-type: none"> • See table
Minimum Load	<ul style="list-style-type: none"> • Minimum load required (see note 1)
Initial Set Accuracy	<ul style="list-style-type: none"> • $\pm 1\%$ max
Line Regulation	<ul style="list-style-type: none"> • $\pm 0.5\%$ max
Load Regulation	<ul style="list-style-type: none"> • $\pm 0.5\%$ max
Cross Regulation	<ul style="list-style-type: none"> • $\pm 5\%$ on dual output models (see note 2)
Transient Response	<ul style="list-style-type: none"> • $< 3\%$ deviation, recovery to within 1% in 2 ms for a 50% load change
Ripple & Noise	<ul style="list-style-type: none"> • 60 mV pk-pk max, 20 MHz bandwidth
Short Circuit Protection	<ul style="list-style-type: none"> • Continuous, with auto recovery
Overvoltage Protection	<ul style="list-style-type: none"> • None
Overcurrent Protection	<ul style="list-style-type: none"> • None
Maximum Capacitive Load	<ul style="list-style-type: none"> • See tables
Temperature Coefficient	<ul style="list-style-type: none"> • $\pm 0.02/^{\circ}\text{C}$ max

General

Efficiency	<ul style="list-style-type: none"> • See tables
Isolation Voltage	<ul style="list-style-type: none"> • 1500 VDC Input to Output • For optional high isolation version 3000 VDC (see note 3) • 1500 VDC Input to Case • 1500 VDC Output to Case
Switching Frequency	<ul style="list-style-type: none"> • 100-400 kHz variable
Isolation Resistance	<ul style="list-style-type: none"> • $10^9\ \Omega$
Power Density	<ul style="list-style-type: none"> • 7.5 W/in³
MTBF	<ul style="list-style-type: none"> • > 2 Mhrs to MIL-HDBK-217F at $25\text{ }^{\circ}\text{C}$, GB

Environmental

Operating Temperature	<ul style="list-style-type: none"> • $-40\text{ }^{\circ}\text{C}$ to $+100\text{ }^{\circ}\text{C}$, derate from 100% load at $+85\text{ }^{\circ}\text{C}$ to no load at $+100\text{ }^{\circ}\text{C}$
Case Temperature	<ul style="list-style-type: none"> • $+100\text{ }^{\circ}\text{C}$ max
Storage Temperature	<ul style="list-style-type: none"> • $-40\text{ }^{\circ}\text{C}$ to $+125\text{ }^{\circ}\text{C}$
Humidity	<ul style="list-style-type: none"> • Up to 95% RH, non-condensing
Cooling	<ul style="list-style-type: none"> • Natural convection

EMC & Safety

Emissions	<ul style="list-style-type: none"> • EN55022 Class A conducted & radiated, with external components, see application note
ESD Immunity	<ul style="list-style-type: none"> • EN61000-4-2, level 3, Perf Criteria A
EFT/Burst	<ul style="list-style-type: none"> • EN61000-4-4, level 3, Perf Criteria A (see note 7)
Surge	<ul style="list-style-type: none"> • EN61000-4-5, installation class 3, Perf Criteria A (see note 7)
Conducted Immunity	<ul style="list-style-type: none"> • EN61000-4-6, 10 V rms, Perf Criteria A
Magnetic Fields	<ul style="list-style-type: none"> • EN61000-4-8, 1 A/m, Perf Criteria A

Input Voltage	Output Voltage	Output Current	Input Current ⁽⁶⁾		Maximum Capacitive Load	Efficiency	Model Number ^(3,4,5)
			No Load	Full Load			
4.5-9 V	5.0 V	600 mA	40 mA	857 mA	2200 µF	70%	JCB0305S05
	9.0 V	333 mA	40 mA	833 mA	470 µF	72%	JCB0305S09
	12.0 V	250 mA	40 mA	810 mA	470 µF	74%	JCB0305S12
	15.0 V	200 mA	40 mA	810 mA	470 µF	74%	JCB0305S15
	24.0 V	125 mA	40 mA	857 mA	220 µF	70%	JCB0305S24
	±5.0 V	±300 mA	40 mA	869 mA	±1000 µF	69%	JCB0305D05
	±9.0 V	±167 mA	40 mA	857 mA	±220 µF	70%	JCB0305D09
	±12.0 V	±125 mA	40 mA	833 mA	±220 µF	72%	JCB0305D12
	±15.0 V	±100 mA	40 mA	810 mA	±220 µF	74%	JCB0305D15
	±24.0 V	±63 mA	40 mA	857 mA	±100 µF	70%	JCB0305D24
9-18 V	5.0 V	600 mA	20 mA	328 mA	2200 µF	76%	JCB0312S05
	9.0 V	333 mA	20 mA	324 mA	470 µF	77%	JCB0312S09
	12.0 V	250 mA	20 mA	316 mA	470 µF	79%	JCB0312S12
	15.0 V	200 mA	20 mA	316 mA	470 µF	79%	JCB0312S15
	24.0 V	125 mA	20 mA	316 mA	220 µF	79%	JCB0312S24
	±5.0 V	±300 mA	20 mA	324 mA	±1000 µF	77%	JCB0312D05
	±9.0 V	±167 mA	20 mA	320 mA	±220 µF	78%	JCB0312D09
	±12.0 V	±125 mA	20 mA	320 mA	±220 µF	78%	JCB0312D12
	±15.0 V	±100 mA	20 mA	320 mA	±220 µF	78%	JCB0312D15
	±24.0 V	±63 mA	20 mA	320 mA	±100 µF	78%	JCB0312D24
18-36 V	5.0 V	600 mA	12 mA	156 mA	2200 µF	80%	JCB0324S05
	9.0 V	333 mA	12 mA	156 mA	470 µF	80%	JCB0324S09
	12.0 V	250 mA	12 mA	152 mA	470 µF	82%	JCB0324S12
	15.0 V	200 mA	12 mA	152 mA	470 µF	82%	JCB0324S15
	24.0 V	125 mA	12 mA	156 mA	220 µF	80%	JCB0324S24
	±5.0 V	±300 mA	12 mA	160 mA	±1000 µF	78%	JCB0324D05
	±9.0 V	±167 mA	12 mA	158 mA	±220 µF	79%	JCB0324D09
	±12.0 V	±125 mA	12 mA	156 mA	±220 µF	80%	JCB0324D12
	±15.0 V	±100 mA	12 mA	156 mA	±220 µF	80%	JCB0324D15
	±24.0 V	±63 mA	12 mA	156 mA	±100 µF	80%	JCB0324D24
36-72 V	5.0 V	600 mA	8 mA	81 mA	2200 µF	77%	JCB0348S05
	9.0 V	333 mA	8 mA	80 mA	470 µF	78%	JCB0348S09
	12.0 V	250 mA	8 mA	78 mA	470 µF	80%	JCB0348S12
	15.0 V	200 mA	8 mA	78 mA	470 µF	80%	JCB0348S15
	24.0 V	125 mA	8 mA	78 mA	220 µF	80%	JCB0348S24
	±5.0 V	±300 mA	8 mA	80 mA	±1000 µF	78%	JCB0348D05
	±9.0 V	±167 mA	8 mA	79 mA	±220 µF	79%	JCB0348D09
	±12.0 V	±125 mA	8 mA	78 mA	±220 µF	80%	JCB0348D12
	±15.0 V	±100 mA	8 mA	78 mA	±220 µF	80%	JCB0348D15
	±24.0 V	±63 mA	8 mA	78 mA	±100 µF	80%	JCB0348D24

Notes

- Minimum load required to meet noise and ripple and initial set accuracy specifications. Below 25% load, noise and ripple increases to 200 mV pk-pk typical and load regulation to ±1% max.
- Cross regulation is ±5% when one output is at 100% the other is varied between 25% and 100%.
- For optional 3000 VDC isolation, add suffix '-H' to end of part number.
- For optional metal case version, add suffix '-M' to end of part number, eg. JCB0324S12-HM
- For alternative pin out, add suffix '-Z' to end of part number, eg. JCB0324S12-HMZ
- Input current measured at nominal input voltage
- A 220 µF/100 V capacitor across the input is required in order to meet EN61000-4-4 & EN61000-4-5.

Mechanical Details and Application Notes

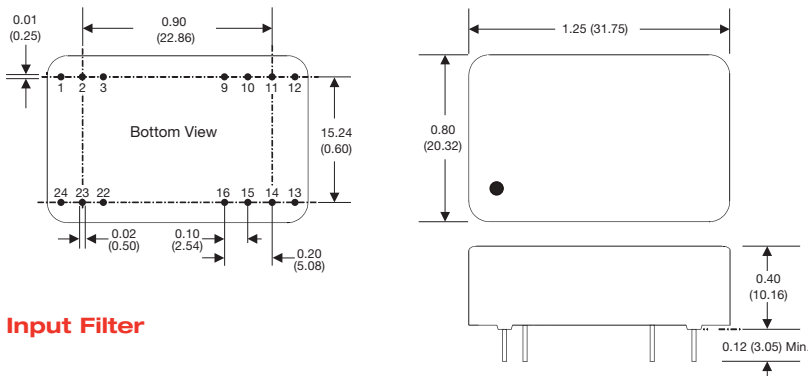

Input Filter

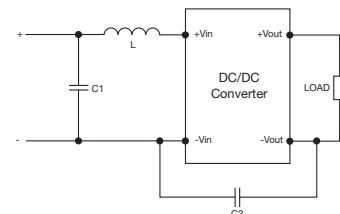

Model	C1	L	C2
JCB0305	220 µF/100 V	12 µH	
JCB0312	220 µF/100 V	12 µH	
JCB0324	220 µF/100 V	12 µH	470 pF/2 KV/MLCC*
JCB0348	220 µF/100 V	12 µH	470 pF/2 KV/MLCC*

*or higher for -H

PIN CONNECTIONS						
Pin	Single	Dual	Single-H	Dual-H	Single-Z, or -HZ	Dual-Z, or -HZ
1	+Vin	+Vin	N.P.	N.P.	N.P.	N.P.
2	N.C.	-Vout	-Vin	-Vin	-Vin	-Vin
3	N.C.	Common	-Vin	-Vin	-Vin	-Vin
9	N.P.	N.P.	N.P.	Common	N.P.	Common
10	-Vout	Common	N.P.	N.P.	N.P.	N.P.
11	+Vout	+Vout	N.C.	-Vout	N.C.	-Vout
12	-Vin	-Vin	N.P.	N.P.	N.P.	N.P.
13	-Vin	-Vin	N.P.	N.P.	N.P.	N.P.
14	+Vout	+Vout	+Vout	+Vout	+Vout	+Vout
15	-Vout	Common	N.P.	N.P.	N.P.	N.P.
16	N.P.	N.P.	-Vout	Common	-Vout	Common
22	N.C.	Common	+Vin	+Vin	+Vin	+Vout
23	N.C.	-Vout	+Vin	+Vin	+Vin	+Vout
24	+Vin	+Vin	N.P.	N.P.	N.P.	N.P.

N.C. - No Connection N.P. - No Pin

Notes

- All dimensions are in inches (mm)
- Weight: 0.04 lbs (20 g) approx.
- Pin diameter: 0.02±0.002 (0.5±0.05)
- Pin pitch tolerance: ±0.014 (±0.35)
- Case tolerance: ±0.02 (±0.5)