

Vandal-proof push-button switches, V16 series



Switch type	vandal resistant
Operating temperature	-20 ÷ 70°C
Electrical life	2.10 ⁵ cycles
Mechanical durability	1.10 ⁶ cycles
Sealing	IP65
Contacts configuration	SPST- NO
Switching method	OFF-(ON)
Stable positions number	monostable
Switching torque	5.5 N
DC contacts rating *	2.0A / 48V
Max. contact resistance:	50mΩ
Test voltage	2.0 kV
Contact material	silver alloy
Button material	stainless steel
Diameter	16mm
Body colour	silver

* at resistance load

Part. №	Leads	Illumination	Dimension
V16-10-S	screw terminals	-	Fig. 1
V16-10D-12R-S	solder lugs	Red LED, point light	Fig. 2

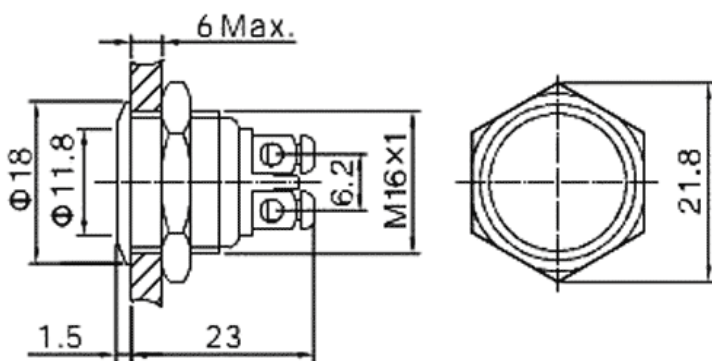

Fig. 1

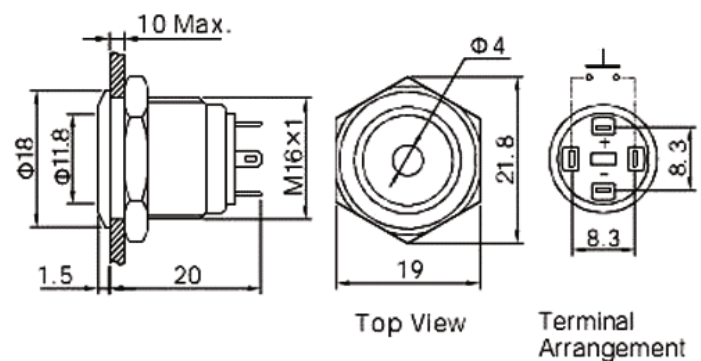

Fig. 2