

Quick flux PCB components

LED lighting systems

Easy touch to the technological LED revolution.

The PCB/QUICK_FLUX_4XQE_REV1.0 is ideal component for building pre-commercial RGBW - LED decorative and architectural lighting products.

By PCB platform you can easily and flexibly build custom technical parameters for your prototype or small series of luminaires.

Enjoy the available solution of the new platform "QUICK FLUX-PCB, which guarantees you easily switch to finished lighting modules series.

QUICK FLUX-PCB offers the freedom to differentiate on lumen output, efficacy and lifetime.

FEATURES:

- Focused on prototypes and small series;
- 100% compatibility with CREE LED series Xlamp XQ-E, XQ-E Hi, XQ-A;
- Color mix lighting, White light mixing;
- Easy transition to mass production with the solutions by this platform(QUICK FLUX RGBW mini);
- Compatibility with LEDIL optics

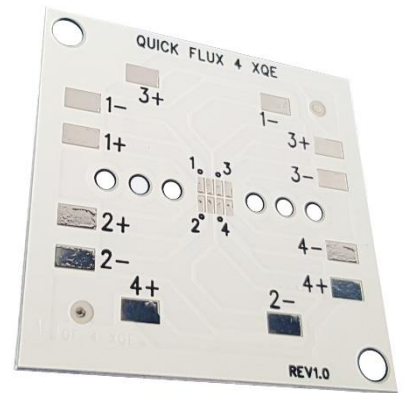

TYPICAL APPLICATIONS

- Architectural;
- Exterior Area;
- And many other applications.

Mechanical characteristics

Dimensions	Typ	Unit
Length	35	mm
Width	35	mm
Height	1.5	mm
Mounting holes for screws	3.2	mm

Note: production tolerances in the dimensions +/- 0.4mm.

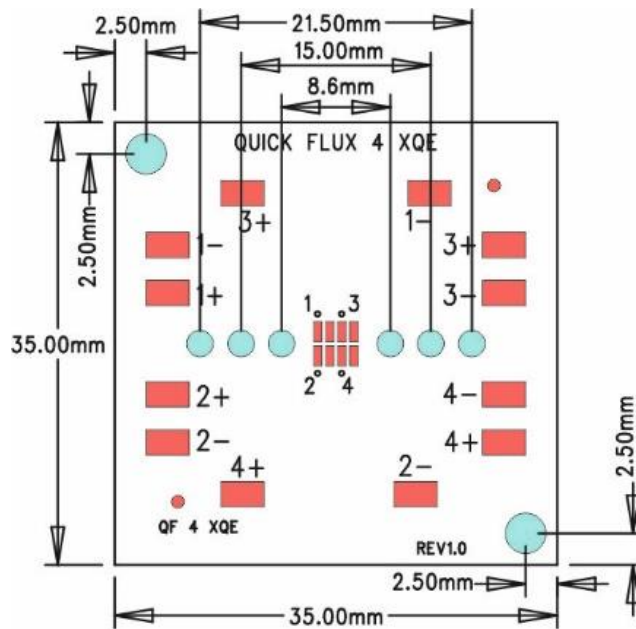

Mounting card components

CREE Xlamp	XQ-E, XQ-E HI, XQ-A, XQ-D, XQ-E Torch
Ledil Oy	REBECCA-RGB, GERI-RZ, ZOWIE-MIDI-RZ, RGBX2-S, MIRELLA-50-S-PIN-RZL

Information on all of the manufacturers can be found <http://www.comet.bg/?cid=92>

Quick links

Everything about LED lighting from Comet Electronics
<https://store.comet.bg/en/Catalogue/GROUP/LEDL/>

Everything about electronic components from Comet Electronics
<https://store.comet.bg/en/Catalogue/>

Contact details and suggested suppliers

Technical support: support@comet.bg

Commercial information office@comet.bg

Quick flux

LED lighting systems

Your best LED solution

PCB components