

GPS+GSM Combo Antenna **ANTB057**

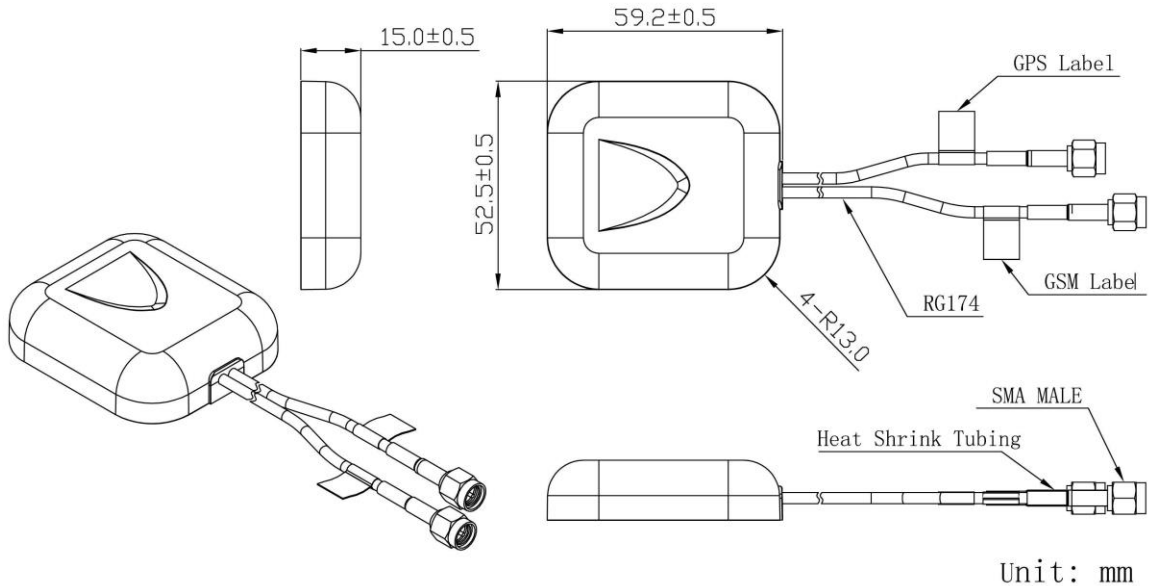

DIMENSIONS



SPECIFICATIONS

Item		Specifications	
GPS Antenna	Dielectric Antenna	Center Frequency	1575.42±1MHz
		Band Width	CF±5MHz
		Polarization	RHCP
		Gain	2dBic (Zenith)
		V.S.W.R	<1.5
		Impedance	50Ω
		Axial Ratio	3dB (max)
	LNA	Gain	28±2dB
		Noise Figure	<2dB
		V.S.W.R	<2.0
Supply Voltage		2.2~5V DC	
Current Consumption		5~15mA	
GSM Antenna		Frequency Range	824~960MHz/1710~2170MHz
		V.S.W.R (min)	<2.5
		Polarization	Linear
		Gain	2dBi
		Impedance	50Ω
Mechanical		Cable	RG174
		Connector	SMA/MCX/FAKRA or others
		Radome Material	ABS
		Mounting Method	Magnet/Adhesive
Environmental		Operating Temperature	-40℃~+85℃
		Relative Humidity	Up to 95%
		Ingress Protection	IP65~IP66
		Vibration	10 to 55Hz with 1.5mm amplitude 2hours
		Environmentally Friendly	ROHS Compliant

Radiation Pattern

GPS Antenna

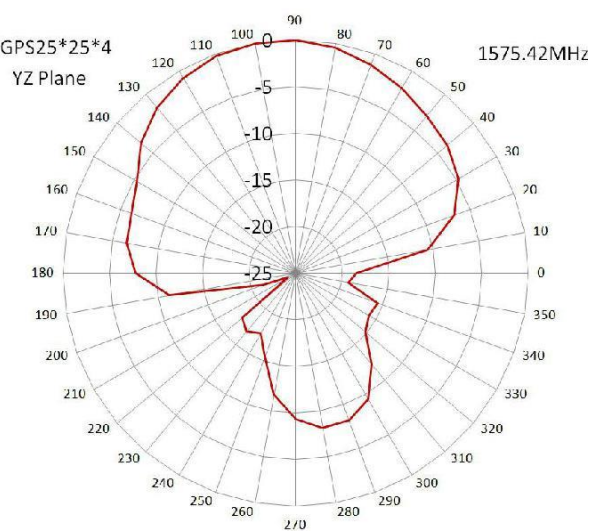
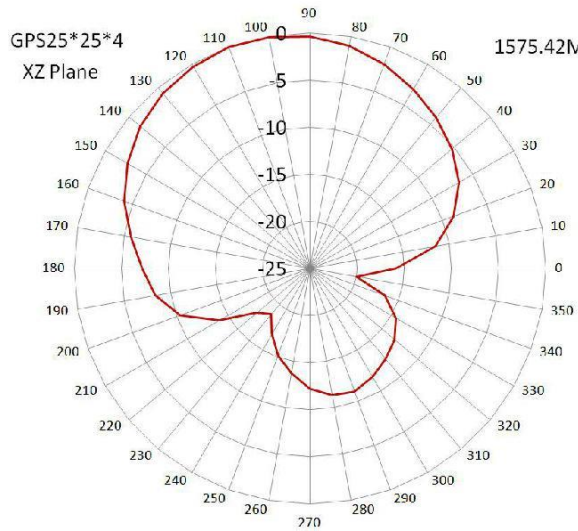
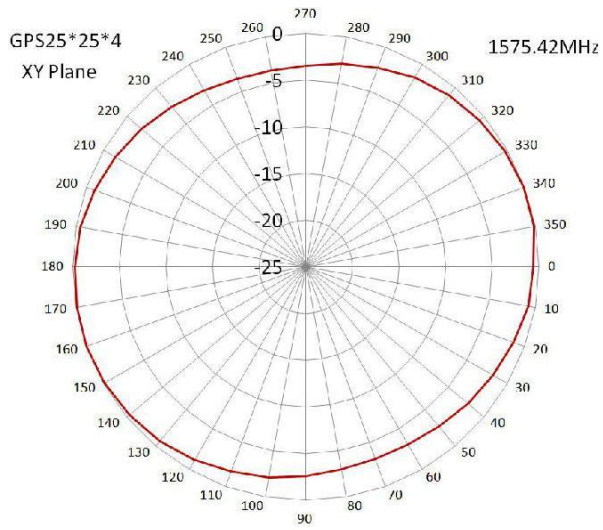

GSM Antenna

