

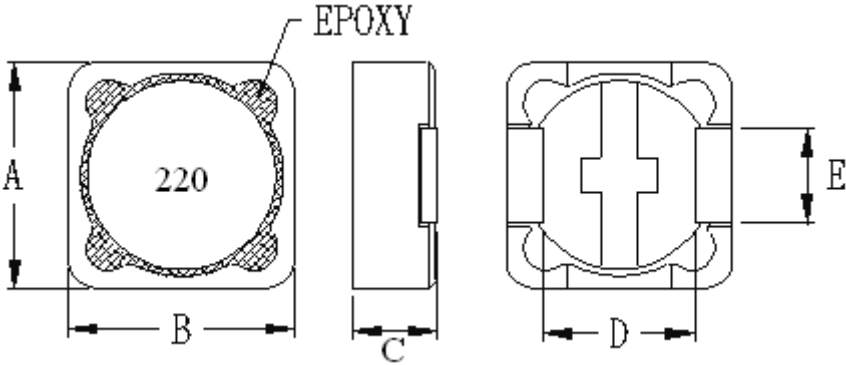

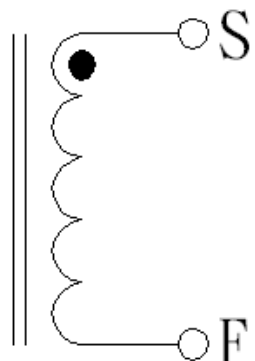



# SPECIFICATION FOR APPROVAL

|  |             |   |
|--|-------------|---|
| CUSTOMER:  |             | DATE:   |
| PART NO: SRI1205-220M  |             | DWG.NO: MY1070228   |
| CUSTOMER PART NO:  |             | CUST.DWG.NO:  |
| <p>(1) DIMENSION(UNIT: mm)</p>    |             | A     12.0 ± 0.5     m/m  |
|  |             | B     12.0 ± 0.5     m/m  |
|  |             | C     6.0 (MAX)     m/m   |
|  |             | D     7.6 ± 0.2     m/m   |
|  |             | E     5.0 ± 0.2     m/m   |
|  |             | F     m/m   |
|  |             | G     m/m   |
|  |             | H     m/m   |
|  |             | I     m/m   |
|  |             | J     m/m   |
|  |             | (2)ELECTRICAL REQUIREMENTS  |
| L (uH)   | 22 ± 20%    |  |
| RDC (Ω)  | 0.058 (MAX) |   |
| IDC (A)  | 4 (MAX)     |   |
| TEST CONDITION   | 1KHz / 1V   |   |
|  |             |   |
| <p>APPROVED BY</p> <div style="text-align: right;">  </div> <p>CHECKED BY</p> <div style="text-align: right;">  </div> <p>DRAWN BY</p> <div style="text-align: right;">  </div> |             |   |

**CORE MASTER ENTERPRISE CO., LTD.**

TEL:886-2-8919-1288    FAX:886-2-8919-1298    WEB:www.coremaster.com.tw

# TEST DATA

| CUSTOMER:   |             |                |            | DATE:   |               |              |  |
|---|-------------|----------------|------------|---|---------------|--------------|--|
| PART NO: SRI1205-220M   |             |                |            | DWG.NO: MY1070228   |               |              |  |
| CUSTOMER PART NO :  |             |                |            | CUST.DWG.NO :   |               |              |  |
| TEST CONDITION: 1KHz / 0.25V  |             |                |            | DIMENSION (UNIT : mm)   |               |              |  |
| ITEM  | L<br>(uH)   | RDC<br>(Ω)     | IDC<br>(A) | A   | B             | C            |  |
| SPEC  | 22<br>± 20% | 0.058<br>(MAX) | 4<br>(MAX) | 12.0<br>± 0.5   | 12.0<br>± 0.5 | 6.0<br>(MAX) |  |
| 1   | 21.4        | 0.037          | OK         | 12.06   | 12.01         | 5.29         |  |
| 2   | 22.8        | 0.033          | OK         | 12.09   | 12.06         | 5.33         |  |
| 3   | 21.9        | 0.034          | OK         | 12.07   | 12.07         | 5.34         |  |
| 4   | 21.6        | 0.037          | OK         | 12.09   | 12.05         | 5.36         |  |
| 5   | 22.7        | 0.038          | OK         | 12.12   | 12.08         | 5.40         |  |
| 6   | 21.4        | 0.034          | OK         | 12.08   | 12.05         | 5.31         |  |
| 7   | 22.3        | 0.036          | OK         | 12.06   | 12.02         | 5.29         |  |
| 8   | 23.5        | 0.038          | OK         | 12.09   | 12.07         | 5.34         |  |
| 9   | 22.8        | 0.035          | OK         | 12.07   | 12.03         | 5.31         |  |
| 10  | 22.2        | 0.032          | OK         | 12.08   | 12.08         | 5.33         |  |
| $\bar{X}$   | 22.26       | 0.035          |            | 12.081  | 12.052        | 5.33         |  |
| R   | 2.1         | 0.006          |            | 0.06  | 0.07          | 0.11         |  |
| TEST INSTRUMENTS<br>DV-6021 LCR METER<br>VR-131 RDC METER<br>CH-301A BA/S CURRENT |             |                |            | APPROVED BY   |               |              |  |
|   |             |                |            |  |               |              |  |
|   |             |                |            | CHECKED BY  |               |              |  |
|   |             |                |            |  |               |              |  |
|   |             |                |            | DRAWN BY  |               |              |  |
|   |             |                |            |  |               |              |  |

**CORE MASTER ENTERPRISE CO., LTD.**

TEL:886-2-8919-1288    FAX:886-2-8919-1298    WEB:www.coremaster.com.tw