

Mini XLR Jack



RoHS
Compliant



Specifications:

Standard Atmospheric Conditions	The standard range of atmospheric conditions for making measurements and tests are as follows: 1) Between body and conductor : 5°C to 35°C 2) Between conductors not to be contact : 45% to 85% 3) Pressure : 86Kpa to 106Kpa
Current Rating	5A 50V AC

Mechanical

Item	Test Conditions	Performance
Connection Force	Measurement shall be made after connecting and disconnecting using standard plug gauge 3 times	<59N
Disconnection Force		
Terminal Strength	A static load of 0.1N/m(1kgf/cm) shall be applied to the tip of the terminal for 1 min. In any direction	There shall be no damage to the terminal such as cracks, looseness or play electrical, and mechanical characteristics shall be satisfied

Electrical

Contact Resistance	Measured at small current (1A or less) 1,000Hz	$\leq 30m\Omega$
Insulation Resistance	Apply a voltage of 500V DC for 1 min to following portions after which measurement shall be made: (1) Between body and conductor (2) Between conductors not to be contact (3) Between conductors not to be when plug is inserted DC 250V 1 min.	$\geq 100M\Omega$
Dielectric Strength	When has the insulation components test 100V @ 60S	OK

Durability

Solderability Test	The top of the terminals shall be dipped 1mm in the solder bath of 235 \pm 5°C for 3 \pm 0.5 seconds	The area of soldering should be over 75%
Resistance to Soldering Heat Test	Soldering iron method : Bit temperature 260 \pm 5°C application time of soldering iron 3 \pm 0.5 Seconds However excessive pressure shall not be applied to the terminal	Without deformation of case or excessive looseness of terminals electrical characteristics shall be satisfied



Mini XLR Jack

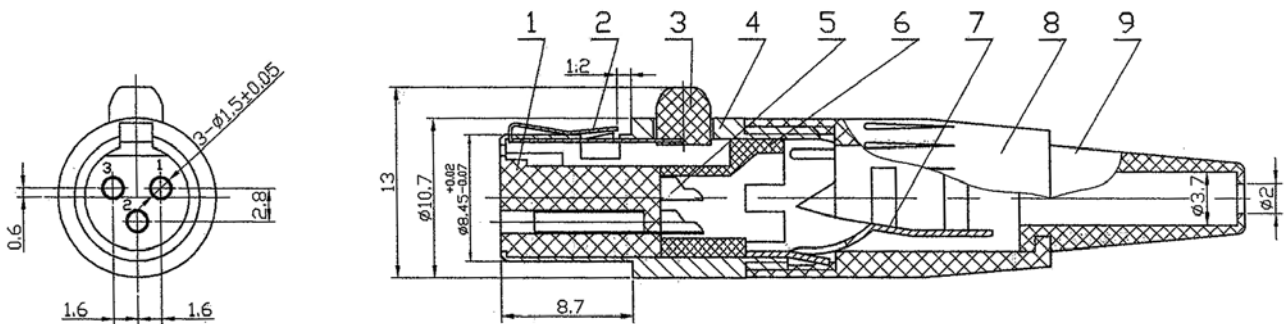

Dimensions: Millimetres

Specification Table

Item	Components	Material	QTY.	Finish
1	Insulator	PA	1	-
2	Copper Pillar	65Mn	1	Nickel Plated
3	Push Button	ABS	1	-
4	Body	H59-1	1	Nickel Plated
5	Female Pin	Phosphor Bronze	3	Gold Plated
6	Medium Cover	PE	1	-
7	Clamp Terminal	H62	1	Nickel Plated
8	Cap	ABS	1	-
9	Boot	PVC	-	-

Part Number Table

Description	Part Number
Mini XLR Jack - 3 Way	SVP556-TA

Important Notice : This data sheet and its contents (the "Information") belong to the members of the Premier Farnell group of companies (the "Group") or are licensed to it. No licence is granted for the use of it other than for information purposes in connection with the products to which it relates. No licence of any intellectual property rights is granted. The Information is subject to change without notice and replaces all data sheets previously supplied. The Information supplied is believed to be accurate but the Group assumes no responsibility for its accuracy or completeness, any error in or omission from it or for any use made of it. Users of this data sheet should check for themselves the Information and the suitability of the products for their purpose and not make any assumptions based on information included or omitted. Liability for loss or damage resulting from any reliance on the Information or use of it (including liability resulting from negligence or where the Group was aware of the possibility of such loss or damage arising) is excluded. This will not operate to limit or restrict the Group's liability for death or personal injury resulting from its negligence. Multicomp is the registered trademark of the Group. © Premier Farnell plc 2012.

www.element14.com
www.farnell.com
www.newark.com

