

Tact Switch Series

TV-06A



Part Number

Model No.	High (L)
TV-06A	3.85

Dimensions

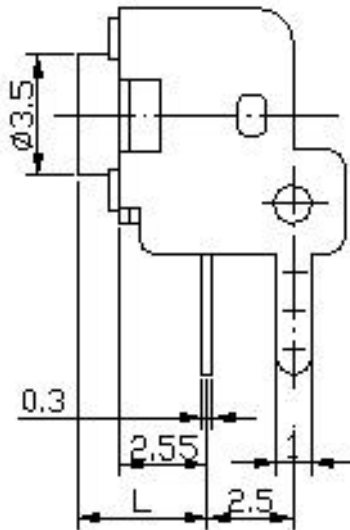
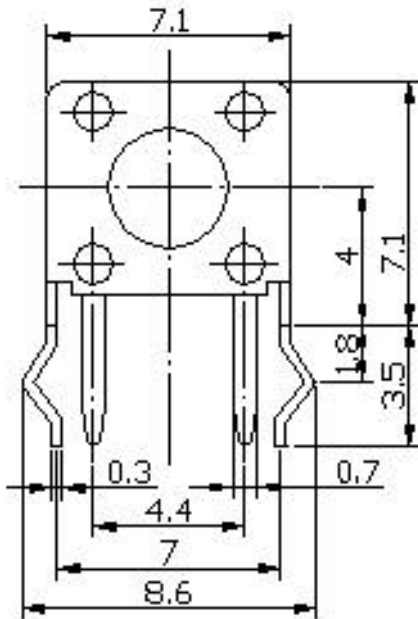

P.C.B LAYOUT

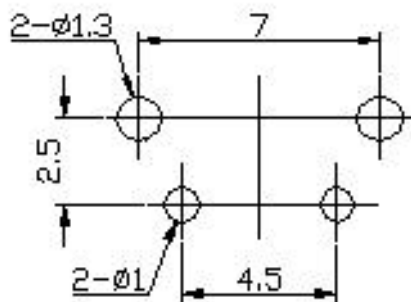

CIRCUIT

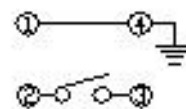

Tact Switch Series

TACTING SWITCH SPECIFICATION

1. GENERAL

1.1 Scope This specification covers the requirements for single key switches which have no key top(TACT SWITCHES : MECHANICAL CONTACT).

1.2 Operating Temperature Range

-20 to 70°C (normal humidity, normal press.)

1.3 Storage Temperature Range

-30 to 80°C (normal humidity, normal press.)

1.4 Test Conditions

Tests and measurements shall be made in the following standard conditions unless otherwise specified:

Normal temperature (temperature 5 to 35°C)

Normal humidity (relative humidity 45 to 85%)

Normal pressure (pressure 860 to 1060 m bars)

In case any question arises from the judgment made, tests shall be conducted in the following conditions:

Temperature (20±2°C)

Relative humidity (65±5%)

Pressure (860 to 1060 m bars)

2. APPEARANCE, STYLE, AND DIMENSIONS

2.1 Appearance

There shall be no defects that affect the serviceability of the product.

2.2 Style and Dimensions

Shall conform to the assembly drawings.

3. TYPE OF ACTUATION

 Tactile feedback

4. CONTACT ARRANGEMENT 1 poles 1 throws

(Details of contact arrangement are given in the assembly drawings.)

5. MAXIMUM RATINGS DC 12 V 50 Ma

TACTING SWITCH SPECIFICATION

6. PERFORMANCE

6.1 Electrical

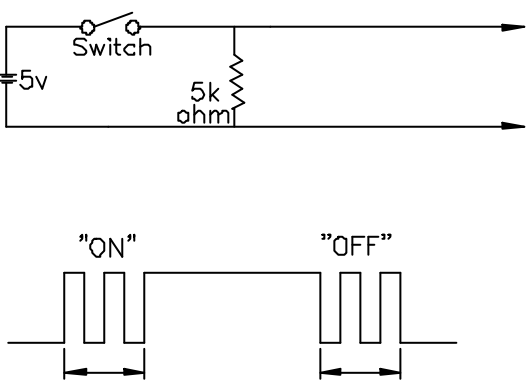
Item	Test Conditions	Requirements
6.1.1. Contact Resistance	Applying a static load twice the actuating force to the center of the stem, measurements shall be made with a 1 kHz small-current contact resistance meter.	<u>100</u> m ohm max.
6.1.2. Insulation Resistance	Measurements shall be made following application of DC <u>250</u> V potential across terminals and across terminals and frame for one minute.	<u>100</u> M ohm min.
6.1.3. Dielectric with-standing voltage	AC <u>500</u> V (50Hz or 60Hz) shall be applied across terminals and across terminals and frame for one minute.	There shall be no breakdown.
6.1.4. Bounce	Lightly striking the center of the stem at a rate encountered in normal use (3 to 4 operations per sec.), bounce shall be tested at "ON" and "OFF". <div style="text-align: center;">  </div>	<u>5</u> m sec max.

TACTING SWITCH SPECIFICATION

6.2 Mechanical

Item	Test Conditions	Requirements
6.2.1. Actuating Force	Placing the switch such that the direction of switch operation is vertical and then gradually increasing the load applied to the center of the stem, the maximum load required for the stem to come to a stop shall be measured.	$\underline{160} \pm \underline{50} \text{ g f}$ OR $\underline{250} \pm \underline{50} \text{ g f}$
6.2.2. Travel	Placing the switch such that the direction of switch operation is vertical and then applying a static load twice the actuating force to the center of the stem, the travel distance for the stem to come to a stop shall be measured.	$\underline{0.3} \pm \underline{0.15} \text{ m m}$
6.2.3. Return Force	The sample switch is installed such that the direction of switch operation is vertical and, upon depression of the stem in its center the whole travel distance, the force of the stem to return to its free position shall be measured.	$\underline{50} \text{ g f min.}$
6.2.4. Stop Strength	Placing the switch such that the direction of switch operation is vertical, a static load of <u>3</u> kgf shall be applied in the direction of stem operation for a period of <u>60</u> seconds.	There shall be no sign of damage mechanically and electrically.
6.2.5 Stem Strength	Placing the switch such that the direction of switch operation is vertical, the maximum force to withstand a pull applied opposite to the direction of stem operation shall be measured.	$\underline{3} \text{ k g f}$

TACTING SWITCH SPECIFICATION

6.3 Environmental

Item	Test Conditions	Requirements
6.3.1. Resistance to Low Temperatures	Following the test set forth below the sample shall be left in normal temperature and humidity conditions for one hour before measurements are made: (1)Temperature: $-30\pm 2^{\circ}\text{C}$ (2) Time: 96 hours (3)Water drops shall be removed.	Item 6.1 Item 6.2.1 Item 6.2.2
6.3.2. Heat Resistance	Following the test set forth below the sample shall be left in normal temperature and humidity conditions for one hour before measurements are made: (1)Temperature: $80\pm 2^{\circ}\text{C}$ (2) Time: 96 hours	Item 6.1 Item 6.2.1 Item 6.2.2
6.3.3. Moisture Resistance	Following the test set forth below the sample shall be left in normal temperature and humidity conditions for one hour before measurements are made: (1) Temperature: $60\pm 2^{\circ}\text{C}$ (2)Relative humidity: 90 to 95% (3) Time: 96 hours (4)Water drops shall be removed.	Contact resistance: <u>200</u> m ohm max. Insulation resistance: <u>10</u> M ohm min. Item 6.1.3 Item 6.1.4 Item 6.2.1 Item 6.2.2
6.3.4. Temperature Cycling	Following five cycles of the temperature cycling test set forth below the sample shall be left in normal temperature and humidity conditions for one hour before measurements are made. During this test, water drops shall be removed. <div style="text-align: center; margin-top: 10px;"> <p>The diagram illustrates a single temperature cycling cycle. The vertical axis represents temperature in degrees Celsius, with a high point at +60 and a low point at -10. The horizontal axis represents time. The cycle consists of four segments: a 2-hour dwell at the high temperature (+60°C), a 1-hour ramp down to the low temperature (-10°C), a 2-hour dwell at the low temperature (-10°C), and a 1-hour ramp up back to the high temperature (+60°C). A bracket above the entire sequence is labeled '1 cycle'.</p> </div>	Item 6.1 Item 6.2.1 Item 6.2.2

TACTING SWITCH SPECIFICATION

6.4 Endurance

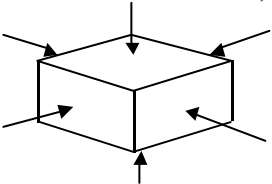
Item	Test Conditions	Requirements
6.4.1. Operating Life	Measurements shall be made following the test set forth below: (1)DC 5V 5mA resistive load (2)Rate of operation: 2 to 3 operations per second (3)Depression: <u>300</u> g f (4)Cycles of operation: <u>10</u> x10 ⁴ cycles	Contact resistance: <u>200</u> m ohm max. Insulation resistance: <u>10</u> M ohm min. Bounce: <u>10</u> m sec max. Actuating force: + <u>30</u> % or - <u>30</u> % of initial force Item 6.1.3 Item 6.2.2
6.4.2. Vibration Resistance	Measurements shall be made following the test set forth below: (1)Range of oscillation: 10 to 55 Hz (2)Amplitude, pk-to-pk:1.5 mm (3)Cycle of sweep: 10 -55 -10 Hz in one minute, approx. (4)Mode of sweep: Logarithmically sweep or uniform sweep (5)Direction of oscillation: Three mutually perpendicular directions, including the direction of stem travel (6)Duration of testing: 2 hours each, for a total of 6 hours	Item 6.1 Item 6.2.1 Item 6.2.2
6.4.3. Impact Shock Resistance	Measurements shall be made following the test set forth below: (1)Acceleration:80g (2)Cycles of test:3 cycles each in 6 directions, for a total of 18 cycles <div style="text-align: center;">  </div>	Item 6.1 Item 6.2.1 Item 6.2.2

TACTING SWITCH SPECIFICATION

7. Switch Handling Precautions

7.1 In case an automatic flow soldering apparatus is used for soldering, adhere to the following conditions:

Item	Soldering condition
7.1.1. Preheat Temperature	100 max (Ambient temperature of printed circuit board on its soldering side)
7.1.2. Preheat Time	45 sec max.
7.1.3. Flux Foaming	To such an extent that fluxes will be kept flush with the printed circuit board's top surface on which components are mounted. Preparatory flux must not be applied to that side of printed circuit board on which components are mounted and to the area where terminals located.
7.1.4. Soldering Temperature	255 max.
7.1.5. Duration of Solder Immersion	5 sec. max.
7.1.6. Allowable Frequency of Soldering process	2 times max.

7.2 Other precautions

7.2.1. Following the soldering process, do not try to clean the switch with a solvent or the like.

7.2.2. Safeguard the switch assembly against flux penetration from its topside.

7.2.3. Please have the products keep in close status and the storage time is 90 days guaranty after delivering the goods at most.