



COMET ELECTRONICS

Electronics components

Bulgaria, Sofia 1582, Drujba 2, 47 Obikolna str. , Call center: +3592/915 58 55,
Fax: +3592/879 32 00, Central office: +3592/915 58 00, e-mail: office@comet.bg

Street lamp body 80W, flat, SLB-80-FL



Street lamp body with sealed LED unit and power unit compartments
Maximum power: 80W



Dimensions, mm: L573xW243xH69mm,
Material: 6061 Aluminium,
Front cover: Transperant glass,
Sealing: Rubber ring.

All dimensions in mm.

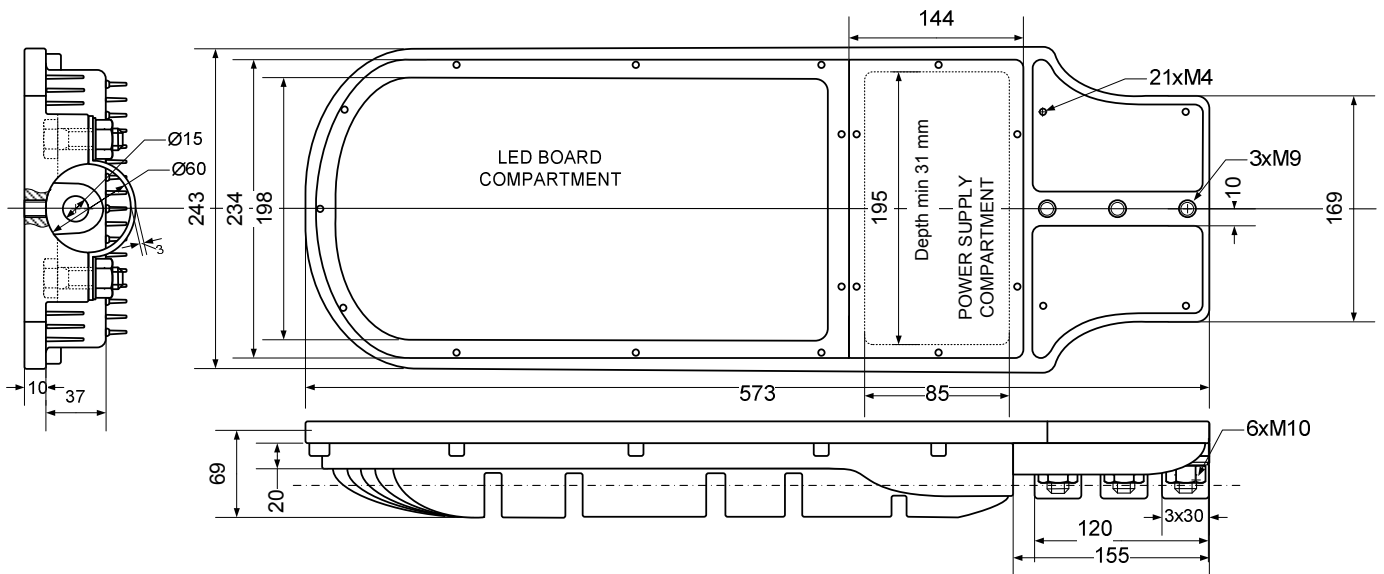

COMET ELECTRONICS

www.comet.bg



COMET ELECTRONICS

Electronics components

Bulgaria, Sofia 1582, Drujba 2, 47 Obikolna str. , Call center: +3592/915 58 55,
Fax: +3592/879 32 00, Central office: +3592/915 58 00, e-mail: office@comet.bg

Street lamp body 150W, flat, SLB-150-FL



Street lamp body with sealed LED unit and power unit compartments
Maximum power: 150W

Dimensions, mm: L783xW348xH69mm,
Material: 6061 Aluminium,
Front cover: Transperant glass,
Sealing: Rubber ring.

All dimensions in mm.

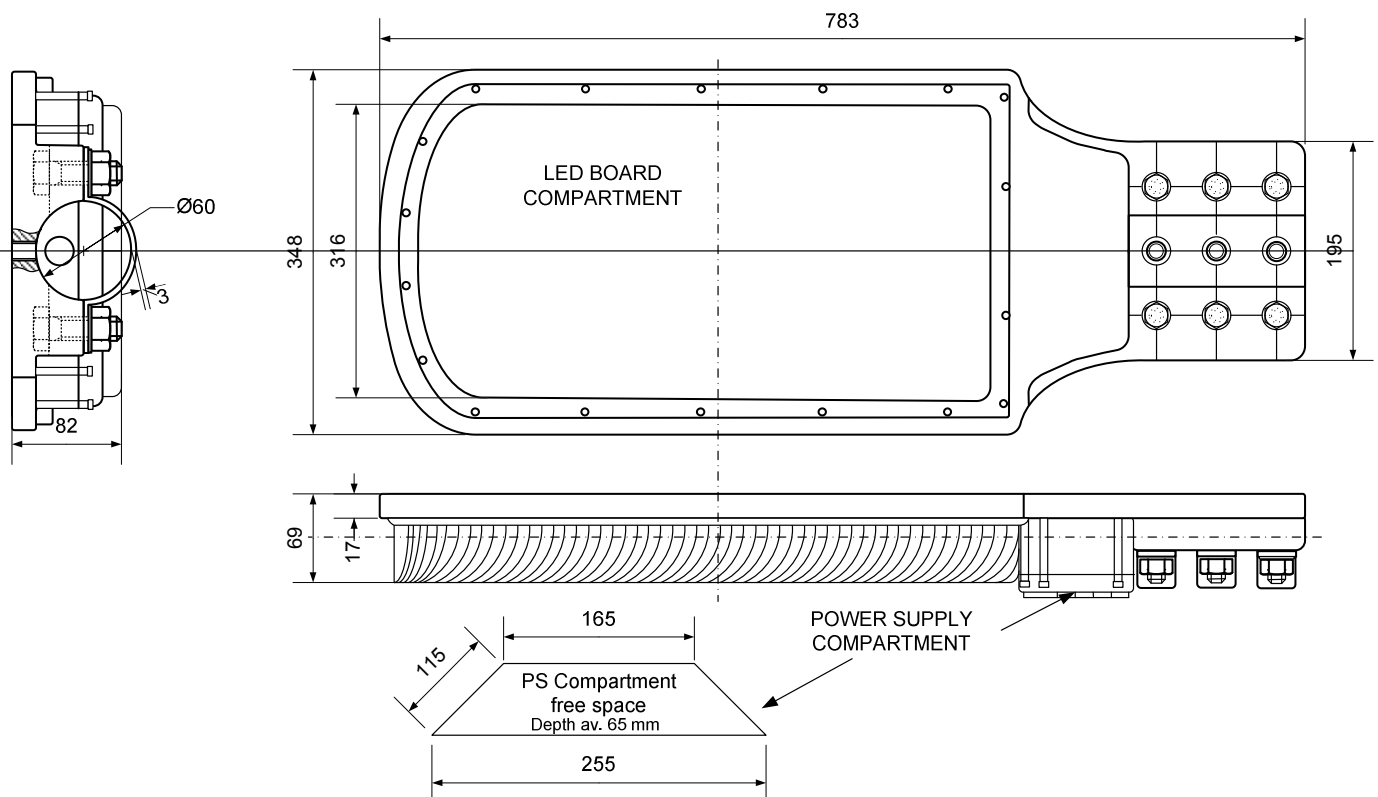



COMET ELECTRONICS

Electronics components

Bulgaria, Sofia 1582, Drujba 2, 47 Obikolna str. , Call center: +3592/915 58 55,
Fax: +3592/879 32 00, Central office: +3592/915 58 00, e-mail: office@comet.bg

Street lamp body 60W, adjustable angle, SLB-60-ADJ



Two sealed compartments for 30W each, with adjustable angle between them.
Maximum power: 60W (2x30W)

Dimensions, mm: L379xW156xH126mm,
Material: 6061 Aluminium,
Front cover: Transperant glass,
Sealing: Rubber ring.

All dimensions in mm.

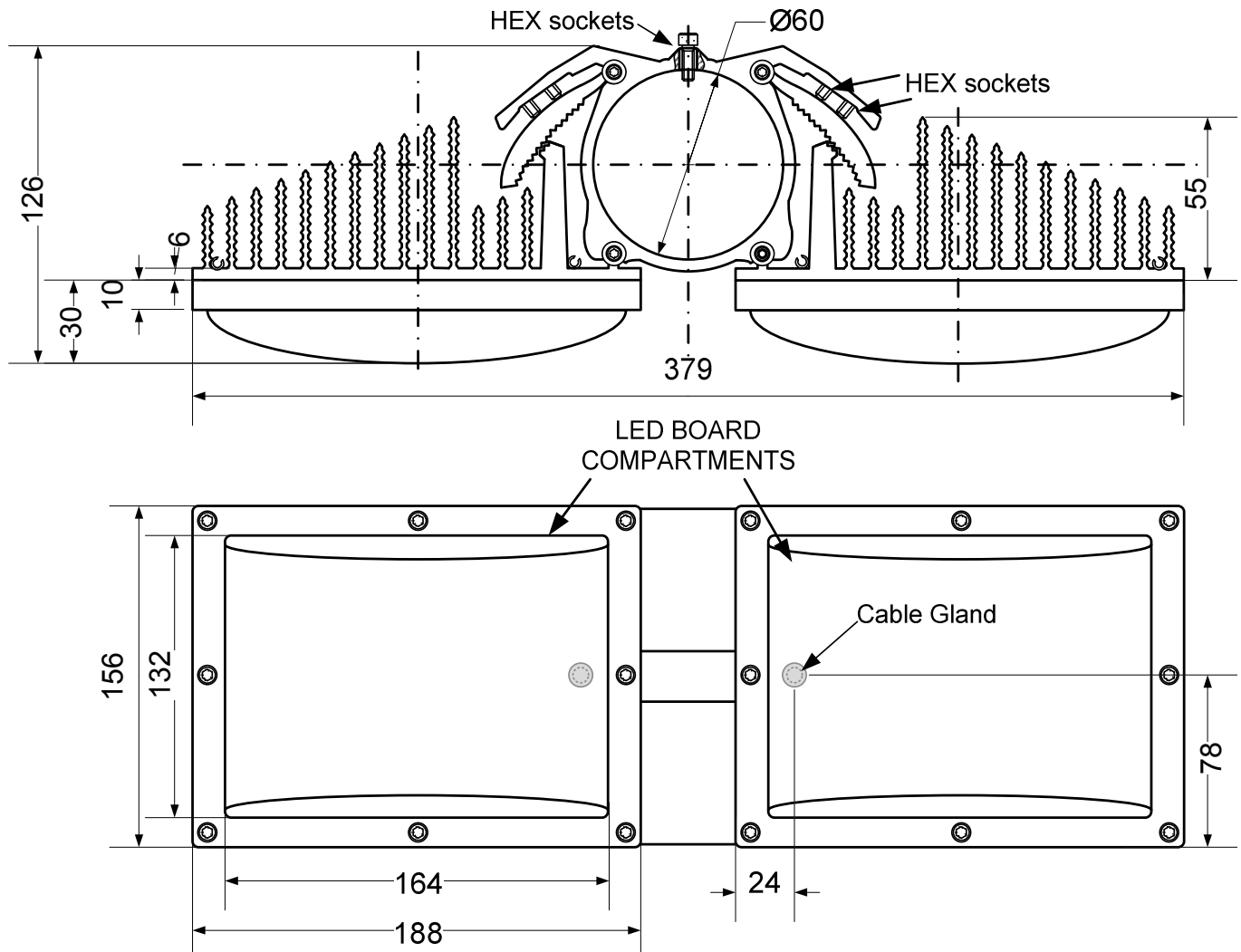

COMET ELECTRONICS

www.comet.bg



COMET ELECTRONICS

Electronics components

Bulgaria, Sofia 1582, Drujba 2, 47 Obikolna str. , Call center: +3592/915 58 55,
Fax: +3592/879 32 00, Central office: +3592/915 58 00, e-mail: office@comet.bg

Street lamp body 120W, adjustable angle, SLB-120-ADJ



Four sealed compartments for 30W each, with adjustable angle between them. Maximum power: 120W (4x30W)

Dimensions, mm: L379xW312xH126mm,
Material: 6061 Aluminium,
Front cover: Transperant glass,
Sealing: Rubber ring.

Street lamp body 180W, adjustable angle, SLB-180-ADJ



Six sealed compartments for 30W each, with adjustable angle between them. Maximum power: 180W (6x30W)

Dimensions, mm: L379xW468xH126mm,
Material: 6061 Aluminium,
Front cover: Transperant glass,
Sealing: Rubber ring.

COMET ELECTRONICS BULGARIA

Bulgaria, Sofia 1582
Drujba 2, 47 Obikolna str.
Call center: +3592/915 58 55,
Fax: +3592/879 32 00
Central office: +3592/915 58 00
e-mail: office@comet.bg

Bulgaria, Sofia, Shop 23 Tsar Samuil str.
tel.: 02 / 915 58 20, 02 / 915 58 55,
Fax:02 / 951 52 67
e-mail: sofia@comet.bg

Bulgaria, Plovdiv, Shop
10 Hr. Dukmedjiev str
tel.: 032 / 63 41 86,
Fax: 032 / 62 89 09
e-mail: plovdiv@comet.bg

COMET ELECTRONICS ROMANIA

Romania, Bucharest, Office, Shop
Str. Grigore Ionescu No 94, Bloc T7B, Parter,
Sector 2
phone: +40.31.226.2222, fax: +40.21.243.40.90
e-mail: office@comet.srl.ro

COMET ELECTRONICS SERBIA

Bulevar Arsenija Černojeviča broj 17
11070 Novi Beograd
Tel.: 00 381 11 213 41 80, 00 381 11 213 61 45
fax: 00 381 11 311 39 42
e-mail: office@comet.rs

COMET ELECTRONICS
www.comet.bg