

AK550/..DS-7.0-V-GREY



A Phoenix Mecano Brand

Technical Data

Wire sizes		Insulating Material	
Solid min	0.08 mm ²	Material	PA 6.6
Solid max	1.5 mm ²	Flammability Class	UL 94 V-0
Stranded (flexible) min	0.08mm ²	Temperatures	
Stranded (flexible) max	1.0 mm ²	Operating Temperature	-30 °C - 105 °C
Stranded with Ferrule min	0.14 mm ²	Store Temperature	-40 °C - 105 °C
Stranded with Ferrule max	0.5 mm ²	Wave Soldering Process	
Dimensions		Soldering Temperature, recommended	265 °C
Stripped Length	5.5 mm	Peak Soldering Time, recommended	3-4 s
PCB Hole Diameter	1.2 mm	Reflow Process	
Materials		Soldering Temperature, recommended	-
Clamp	Brass	Peak Soldering Time, recommended	-
Wire Guard	Stainless Steel		
Screw	Steel		

Colours

	GREY, RAL 7016
	PEBBLE GREY, RAL 7032
	GREEN, RAL 6018
	LIGHT GREEN, similar RAL 6018

Colours according to RAL, there may be variations on colour due to production conditions. Special colours on request.

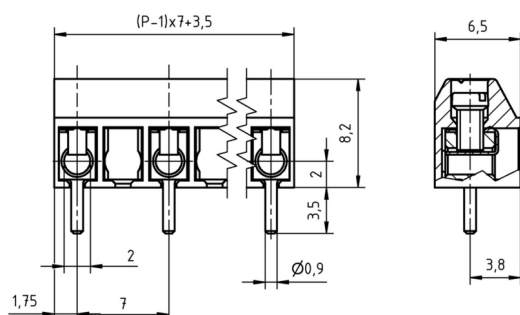

Order Data (Spacing 7.0 mm)

Poles	Width (mm)	Article Designation	Article Number	PU
2	10.50	AK550/2DS-7.0-V-GREY	50550020211 G	250
3	17.50	AK550/3DS-7.0-V-GREY	50550030211 G	250
4	24.50	AK550/4DS-7.0-V-GREY	50550040211 G	250
5	31.50	AK550/5DS-7.0-V-GREY	50550050211 E	100
6	38.50	AK550/6DS-7.0-V-GREY	50550060211 D	50
7	45.50	AK550/7DS-7.0-V-GREY	50550070211 D	50
8	52.50	AK550/8DS-7.0-V-GREY	50550080211 D	50

Accessoires

Figure	Designation	Article Number
	Bridge, 2-pole, insulated, BRI/2-7.0/7.62-L7.5-LIGHT GREY	Art.-Nr. 50000000018

See pages 282 ff for detail and general accessories and see pages 12/13 concerning services.

Ratings

UseGroup	C _{RU} US			VDE	
	B	C	D		
Rated Voltage	300 V	150 V	300 V	450 V	
Rated Current	6 A	6 A	6 A	13.5 A	
Rated Wire Size				min	max
- solid	AWG 28-16	AWG 28-16	AWG 28-16	0.5 mm ²	1.0 mm ²
- stranded	AWG 28-16	AWG 28-16	AWG 28-16	0.5 mm ²	1.0 mm ²
Torque	0.25 Nm	0.25 Nm	0.25 Nm	0.20 Nm	
Screw Size	M2	M2	M2	M2	
Test Voltage	1.60 kV	1.30 kV	1.60 kV	2.5 kV	