

REV.	DESCRIPTION	DRAWN	DATE
1	INITIAL RELEASE	FROS	2017/06/29

SPECIFICATION:

1. ELECTRICAL
 - 1.1 Current Rating: 0.2A
 - 1.2 Voltage Rating: 30V
 - 1.3 Contact Resistance: 100mΩ max.
 - 1.4 Insulation Resistance: 50MΩ at 100V DC
 - 1.5 Dielectric Withstanding Voltage: 90V AC for 1 minute
2. MECHANICAL
 - 2.1 FPC Resistance Force: 0.15N min. (per pin)
 - 2.2 Durability: 10 cycles
3. ENVIRONMENTAL
 - 3.1 Operating temperature range: -55°C~+85°C
 - 3.2 Storage temperature range: -55°C~+85°C
4. SOLDER ABILITY
 - 4.1 Recommended IR-Reflow Temperature: 260°C

POS.	PART NO.	DIMENSIONS					
		A	B	C	D	E	F
41	317B-41BAA	13.80	11.40	12.00	12.60	13.30	12.60
45	317B-45BAA	15.00	12.60	13.20	13.80	14.50	13.80
51	317B-51BAA	16.80	14.40	15.00	15.60	16.30	15.60
61	317B-61BAA	19.80	17.40	18.00	18.60	19.30	18.60
67	317B-67BAA	21.60	19.20	19.80	20.40	21.10	20.40
71	317B-71BAA	22.80	20.40	21.00	21.60	22.30	21.60

5	MYLAR	Polyimide film tape
4	HOLD DOWN	Phosphor Bronze, Gold plating over Nickel
3	SPACER	LCP, UL94V-0
2	CONTACT	Phosphor Bronze, Gold plating over Nickel
1	HOUSING	LCP, UL94V-0

NO.		PART NAME	DESCRIPTION
UNLESS OTHERWISE SPECIFIED TOLERANCE			
UNIT:	DECIMAL	LINEAR	ANGLES
mm	X.	±0.50	±5°
	X.X	±0.25	±3°
	X.XX	±0.12	±1°
WWW.ATTEND.COM.TW			
DRAWN	Fros	2017/06/29	DRAWN NAME:
CHECKED	Tim	2017/06/29	FPC Connector, 0.3 Pitch, H=1.0mm Lower Contact, Front Flip SMT Type
APPROVED	Ken	2017/06/29	PRODUCT NO. see table
SCALE	SHEET	SIZE	FILE NAME
6.25	1/1	A4	317B-XXBAA_B_1

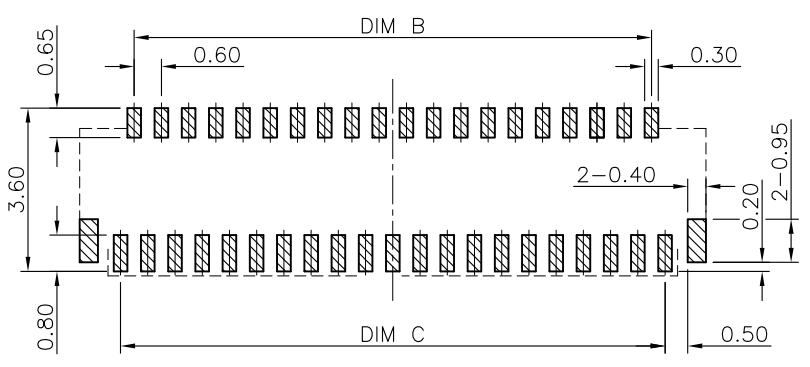
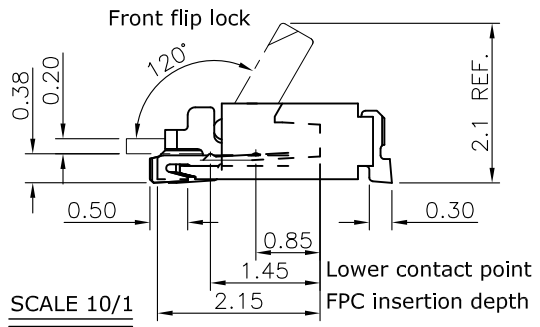
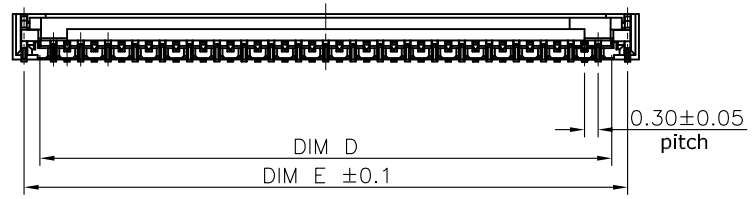
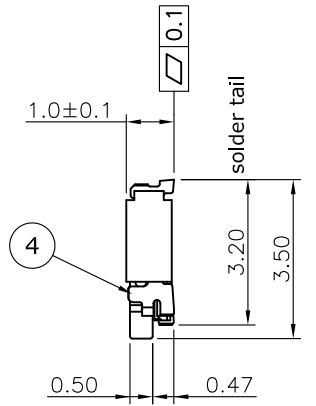
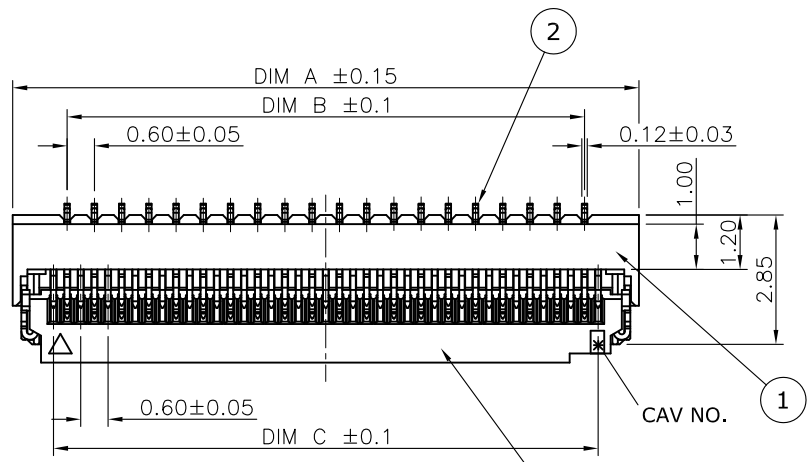

RECOMMENDED LAYOUT (TOP VIEW)
GENERAL TOLERANCE: ±0.05

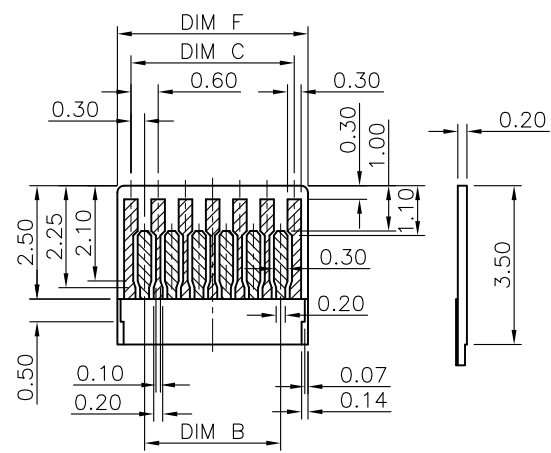

RECOMMENDED FPC/FFC LAYOUT
GENERAL TOLERANCE: ±0.03

REV.	DESCRIPTION	DRAWN	DATE
1	INITIAL RELEASE	FROS	2017/06/29

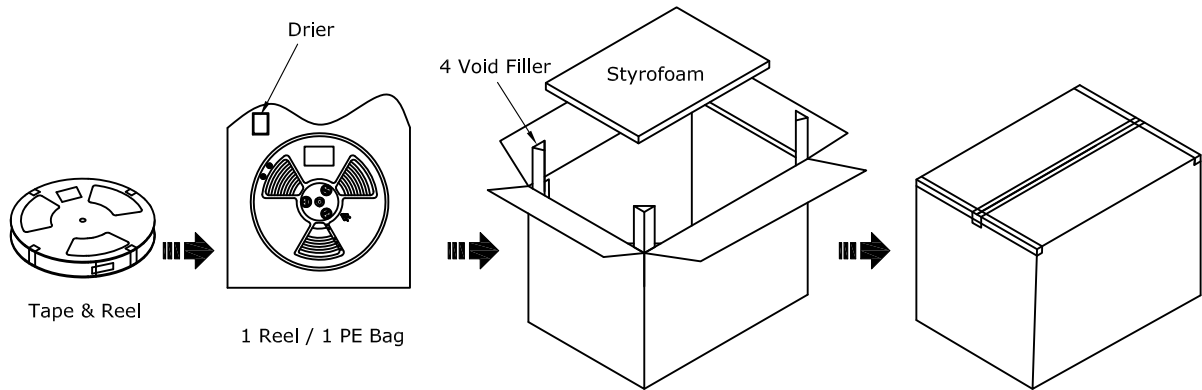
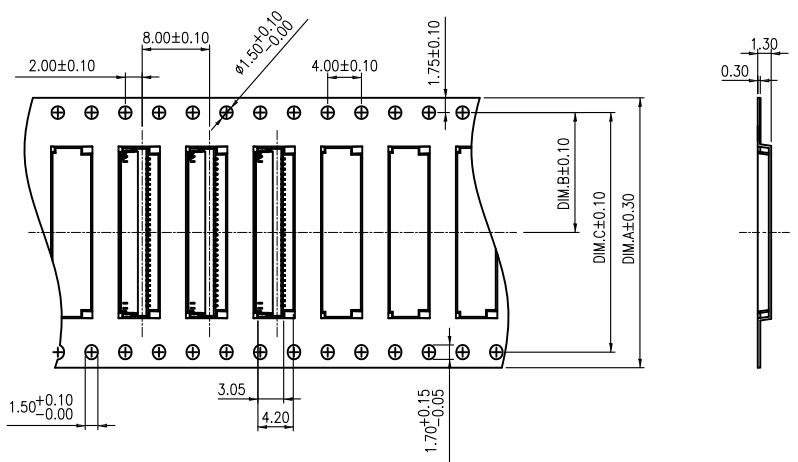
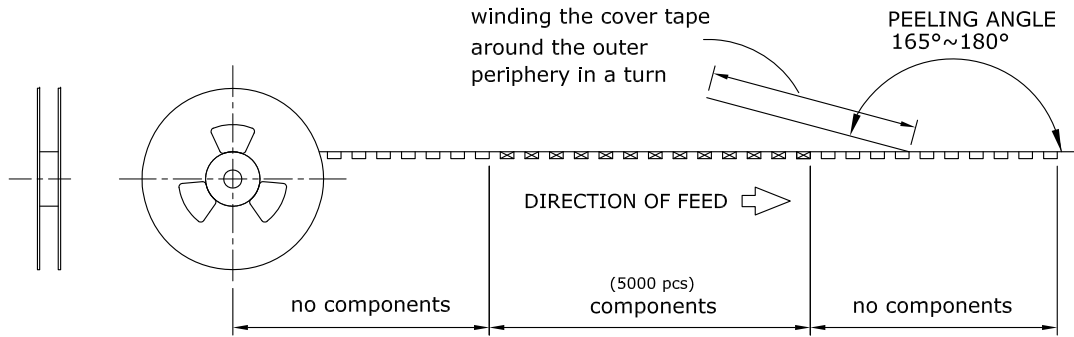

Pos.	DIMENSIONS TABLE			PACKAGING	
	A	B	C	CARTON 35X35X34cm	
41	24.00	11.50		10 REEL	50,000 PCS
51					
61	32.00	14.20	28.40	8 REEL	40,000 PCS
67				6 REEL	30,000 PCS
71	44.00	20.20	40.40		

UNLESS OTHERWISE SPECIFIED TOLERANCE					
UNIT:	DECIMAL	LINEAR	ANGLES	 www.attend.com.tw	
mm	X.	±0.50	±5°		
	X,X	±0.25	±3°		
	X,XX	±0.12	±1°		
DRAWN	Fros	2017/06/29	DRAWN NAME: Packaging of 317B-XXBAA		
CHECKED	Tim	2017/06/29			
APPROVED	Ken	2017/06/29	PRODUCT NO.		
SCALE	N/A	SHEET	SIZE	FILE NAME	
		1/1	A4	317B-XXBAA_D_1	