	Weightless End Device Module Evaluation Board Datasheet	Version 1.1 Author ubiik DOC Date..... 03/13/2018
---	---	---

End Device Module Evaluation Board

Low-Power Wide Area Network Technology: Weightless®

General Features

- On-board Weightless™ protocol stack
- AT command interface over UART
- Dimension/Weight: 65 x 55 mm/ 18g
- Environmentally friendly, RoHS compliant
- Giteki, FCC, CE compliant
- Device Firmware Upgrade (DFU) over UART
- ARM® Cortex®-M3@40MHz running FreeRTOS
- 256kB Flash / 32kB RAM

Operational

- USB port operating voltage: 5V
- Battery port operating voltage: 1.8V to 5.5V (Type. 3V)
- Temperature range: Operating: -10°C ~ 50°C; Storage: -20°C ~ 60°C
- Low-power consumption
- Programmable TX data rate from 625bps to 100kbps with PSK/GMSK modulation
- High-performance low-power ARM® Cortex®-M3 running at 40 MHz

RF/Analog Features

- Low-Power Long Range Transceiver operating in the 868/915/923MHz frequency bands
 - High Receiver Sensitivity: -120dBm@ 6.25Kbps
 - Transmit Power: Adjustable up to 13dBm, optionally PA version output power up to 26dBm
 - PSK/GMSK modulation



Description

Ubiik's End Device Module Evaluation Board (EVB) is a simple way to test and evaluate the End Device Module. The End Device Module is a Low-Power Long Range module with a full Weightless protocol stack up to the AT command interface. The AT command interface offers rapid time to market. With UART & GPIO interfaces, the EVB allows users to add sensors and create prototypes. The End Device module complies with the open, license-free Weightless protocol specifications.

Applications

- Automated Meter Reading
- Home and Building Automation
- Wireless Alarm and Security Systems
- Industrial Monitoring and Control
- Machine to Machine (M2M)
- Internet of Things (IoT)

Revision History

Revision Code	Date	Description	Comments
1.1	Mar. 13, 2018	Initial Release	

Table of Contents

1.0 Features	3
2.0 Pin Configurations	4
3.0 Label Information	7
4.0 Operating Condition	7
5.0 Electrical Characteristics	8
6.0 Reference circuit	9
7. Notice	9
Contact	11

TO OUR VALUED CUSTOMERS AND PARTNERS

It is our intention to provide our valued customers with the best documentation possible to ensure successful use of your Ubiik products. We will strive to improve publications to better suit your needs. Our publications will be refined and enhanced as new volumes and updates are introduced. If you have any questions or comments regarding this publication, please contact the Marketing Communications Department via E-mail at info@ubiik.com. We welcome your feedback. For more information, please visit our website www.ubiik.com

1.0 Features

Specification	Description
Host Interface	AT command interface over UART
MCU	ARM® Cortex®-M3
Clock	40MHz
Flash	256kB
RAM	32kB
Frequency Band	450-507MHz, 840-870MHz, 902-928MHz
Modulation Method	PSK and GMSK
Max. Over-the-Air Data Rate	100kbps
Interfaces	UART & GPIO
Operation Range	>3km LoS; >1km urban environment
Max Transmit Power	13 dBm
Temperature (operating)	-10°C ~ 50°C
Temperature (storage)	-20°C ~ 60°C
Dimensions	65 x 55 mm

2.0 Pin Configurations

Top View

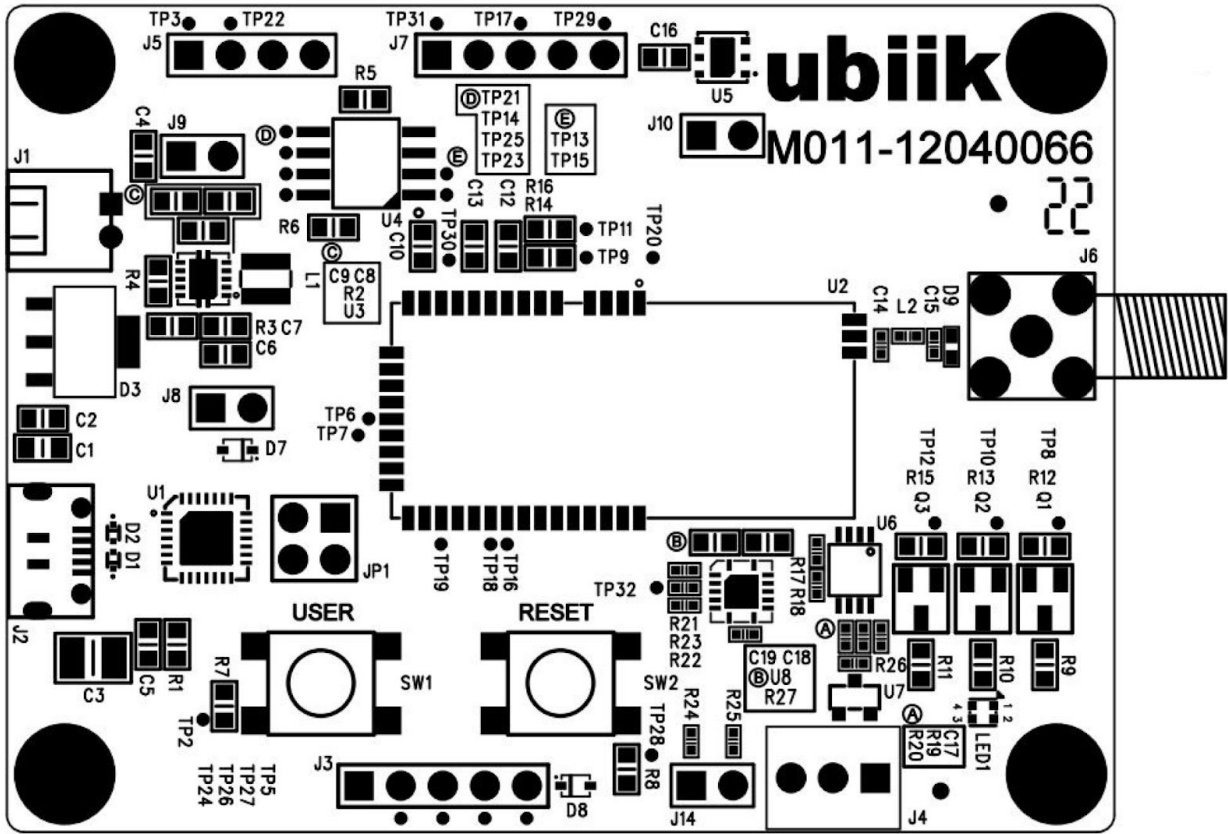

Pin(s)	Symbol	Description
J1 - 1	5V	Power Supply_5V
J1 - 2	GND	Power Supply Ground
J2	Micro USB	Micro USB Connector
J3 - 1	GND	Power Supply Ground
J3 - 2	VDD	3.3V Supply
J3 - 3	N/C	Reserve
J3 - 4	N/C	Reserve
J3 - 5	N/C	Reserve

J4 - 1	N/C	Reserve
J4 - 2	N/C	Reserve
J4 - 3	GND	Power Supply Ground
J5 - 1	VBUS	Power Supply_5V
J5 - 2	VDD	Power Supply_3.3V
J5 - 3	5V	Power Supply_5V
J5 - 4	GND	Power Supply_Ground
J6	RF Connector	Antenna connector, SMA type
J7 - 1	N/C	No Connect
J7 - 2	N/C	Reserve
J7 - 3	N/C	Reserve
J7 - 4	GND	Power Supply_Ground
J7 - 5	N/C	Reserve
J8	JUMPER_2.54mm	Current Measure_3.3V
J9	JUMPER_2.54mm	Current Measure_5V
JP1	JUMPER_2.0mm	UART Interface (See Figure 2.2 below)
SW1	USER	User define, active low
SW2	RESET	Reset input, active low

Figure 2.2 - UART Tx, Rx

note: jumpers can be removed to access the UART Tx, Rx,

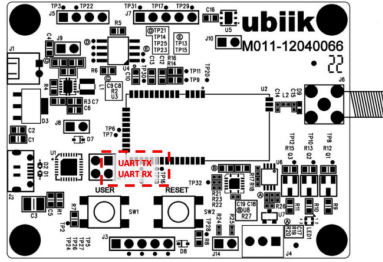

3.0 Label Information

5-1 Image: End-Device Module Label



Variations of Label:

(1) Model: UX8125-M30

- (a) this module supports working frequency 824-960 Mhz,
- (b) RFIC Transmit power set to 13dBm.
- (c) No external PA.

(2) Model: UX8125-M40

- (a) this module supports working frequency 824-960 Mhz,
- (b) RFIC Transmit power set to 26dBm.
- (c) Built external PA

(3) Model: UX8125-M50

- (a) this module supports working frequency 450-507 Mhz,
- (b) RFIC Transmit power set to 26dBm (for 450MHz) and 28dBm (for 470-507MHz)
- (c) Built external PA

4.0 Operating Condition

Table 4 Operating Specification

Parameters		Min	Typ	Max	Unit
Operating Temp		-10		50	degC
Supply Voltage	USB Port(USB peripheral used)		5		V
	Battery Port (USB peripheral not used)	1.8	3	5.5	V

5.0 Electrical Characteristics

7.1 PSK/GMSK Transceiver Specification

Table 7-1 Current Consumption

Mode	Current Consumption
TX	70 mA @ 13 dBm / 26 mA @ 0 dBm
RX	13 mA

6.0 Reference circuit

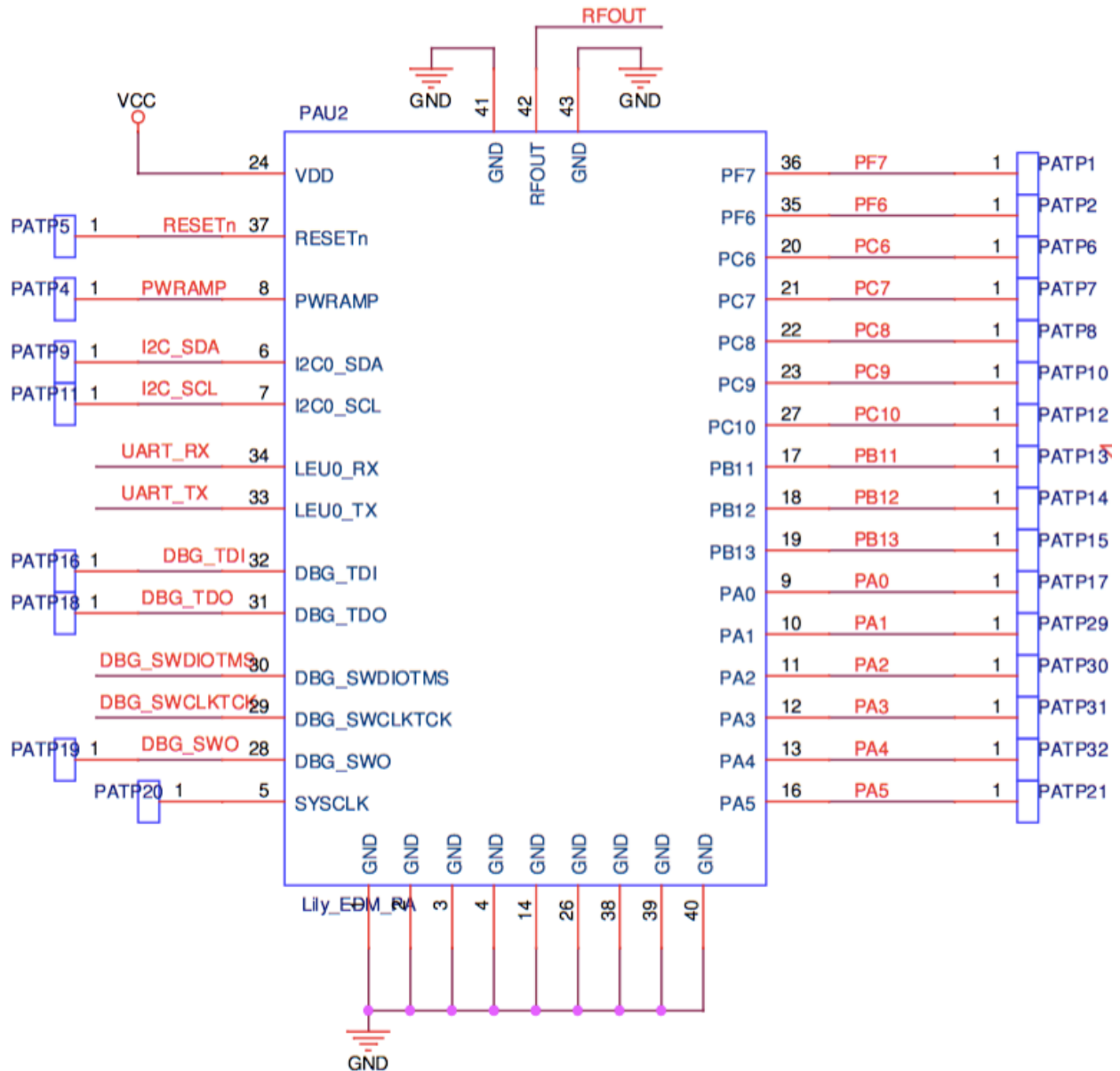

7. Notice

7.1 Handling Conditions

Be careful in handling or transporting products because excessive stress or mechanical shock may break products.

7.2 Cleaning :

Since this Product is Moisture Sensitive, any cleaning is not permitted.

7.3 Operational Environment Conditions :

Products are designed to work for electronic products under normal environmental conditions (ambient temperature, humidity and pressure). Therefore, products have no problems to be used under the similar conditions to the above-mentioned. However, if products are used under the following circumstances, it may damage products and leakage of electricity and abnormal temperature may occur.

- In an atmosphere containing corrosive gas (Cl₂, NH₃, SO_x, NO_x etc.).
- In an atmosphere containing combustible and volatile gases.
- Water splashing place.
- Humid place where water condenses.
- Freezing place.

If there are possibilities for products to be used under the preceding clause, consult with Ubiik before actual use. As it might be a cause of degradation or destruction to apply static electricity to products, do not apply static electricity or excessive voltage while assembling and measuring.

7.4 Input Power Capacity :

Products shall be used in the input power capacity as specified in this specifications. Inform Ubiik beforehand, in case that the components are used beyond such input power capacity range.

Contact

General
info@ubiik.com

Sales:
jay@ubiik.com

END