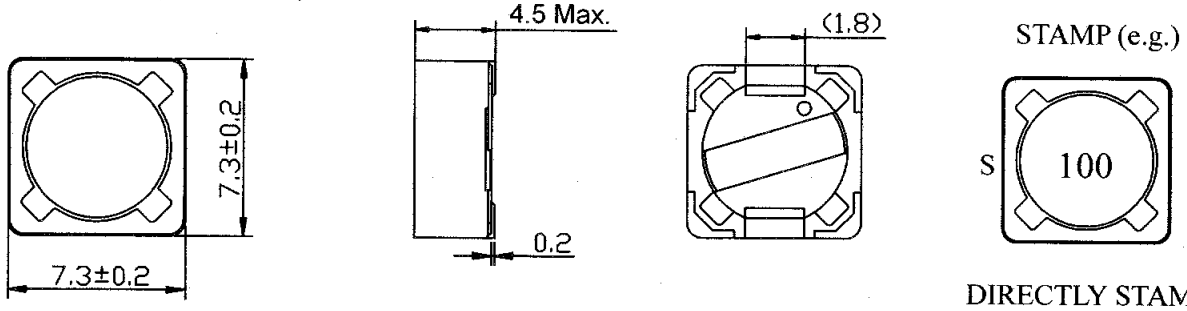


# SPECIFICATION

TYPE

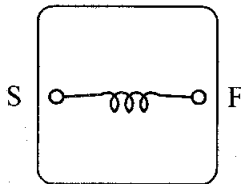
## 1. DIMENSION (UNIT: mm)



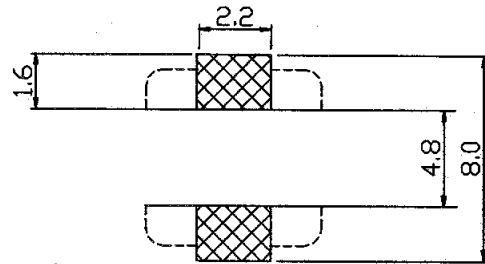
DIRECTLY STAMP

\* DIMENSIONS WITHOUT TOLERANCE ARE APPROX.

## 2. CONNECTION

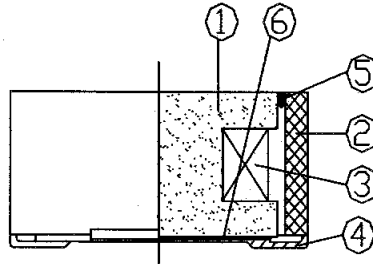


## 3. LAND PATTERN (UNIT: mm)



“S” INDICATES WINDING START.

## 4. CONSTRUCTION



## MATERIAL LIST

No.	PARTS	MATERIAL	MANUFACTURE	COUNTRY OF ORIGIN	UL No.	UL FLAME CLASS	TEMP CLASS
①	DRUM CORE	FERRITE CORE EL8H OR EQUIVALENT	ZHONGSHAN TONICHI FERRITE PRODUCTS CO., LTD.	CHINA	NA	NA	NA
②	RING CORE	FERRITE CORE EL8H OR EQUIVALENT	ZHONGSHAN TONICHI FERRITE PRODUCTS CO., LTD.	CHINA	NA	NA	NA
③	WIRE	POLYURETHANE ENAMELLED COPPER WIRE OR EQUIVALENT	PACIFIC-THAI ELECTRIC WIRE & CABLE CO., LTD.	THAILAND	E142108	NA	155°C
			JUNG SHING WIRE CO., LTD.	CHINA(TAIWAN)	E174837	NA	155°C
			TA YA ELECTRIC WIRE FACTORY	CHINA	E197768	NA	155°C
④	ELECTRODE	C1100(H) OR EQUIVALENT	LIANCHENG ENTERPRISE CO.,LTD	CHINA	NA	NA	NA
		C5191R-H OR EQUIVALENT	JIN SHENG ELECTRONIC CO., LTD.	CHINA	NA	NA	NA
⑤	ADHESIVE	EPOXYRESIN (XNR3614) OR EQUIVALENT	NAGASE& CO., LTD.	JAPAN	NA	NA	NA
⑥	ADHESIVE	EPOXYRESIN (XN1263) OR EQUIVALENT	NAGASE& CO., LTD.	JAPAN	NA	NA	NA
	SOLDER	Sn99.3-Cu0.7OR EQUIVALENT	ALPHA METALS LTD.	CHINA HONG KONG	NA	NA	NA
		Sn99.3-Cu0.7 OR EQUIVALENT	YUNNAN TIN CO.,LTD	CHINA	NA	NA	NA
	STAMP	INK(Z370)OR EQUIVALENT	TOYO INK.	JAPAN	NA	NA	NA

REMARK	SPEC. No. 2/4
<b>LEAD FREE</b>	<b>H500-0428</b>

TYPE

## 5. ELECTRICAL CHARACTERISTICS

No.	CUS. P/N	CEC P/N	STAMP	INDUCTANCE ( $\mu$ H) Within	D.C.R. ( $\Omega$ ) Max.	RATED CURRENT Max. (A)	
						Idc1 Max.	Idc2 Max.
01			100	10 $\pm$ 20%	70.0m	2.10	1.90
02			120	12 $\pm$ 20%	75.0m	1.82	1.80
03			150	15 $\pm$ 20%	85.0m	1.75	1.72
04			180	18 $\pm$ 20%	0.10	1.61	1.67
05			220	22 $\pm$ 20%	0.12	1.40	1.50
06			270	27 $\pm$ 20%	0.14	1.26	1.32
07			330	33 $\pm$ 20%	0.17	1.05	1.21
08			390	39 $\pm$ 20%	0.20	0.98	1.06
09			470	47 $\pm$ 20%	0.24	0.84	1.00
10			560	56 $\pm$ 20%	0.27	0.78	0.98
11			680	68 $\pm$ 20%	0.35	0.75	0.84
12			820	82 $\pm$ 20%	0.42	0.66	0.78
13			101	100 $\pm$ 20%	0.47	0.63	0.70
14			121	120 $\pm$ 20%	0.64	0.56	0.64
15			151	150 $\pm$ 20%	0.73	0.50	0.55
16			181	180 $\pm$ 20%	0.98	0.45	0.50
17			221	220 $\pm$ 20%	1.13	0.41	0.48
18			271	270 $\pm$ 20%	1.38	0.37	0.44
19		<b>A81208011</b>	<b>331</b>	<b>330 <math>\pm</math> 20%</b>	<b>1.65</b>	<b>0.34</b>	<b>0.39</b>
20			391	390 $\pm$ 20%	1.83	0.31	0.37
21			471	470 $\pm$ 20%	2.05	0.29	0.33
22			561	560 $\pm$ 20%	2.57	0.25	0.29
23			681	680 $\pm$ 20%	3.00	0.23	0.27
24			821	820 $\pm$ 20%	3.75	0.21	0.26
25			102	1000 $\pm$ 20%	4.25	0.20	0.23

## \* TESTING INSTRUMENT

INDUCTANCE: HP 4284A OR EQUIVALENT.

D.C.R.:HP34220A OR EQUIVALENT.

## \* TESTING FREQUENCY OF INDUCTANCE: 1 kHz, 1.0V

\* Idc1: THE CURRENT WHEN THE INDUCTANCE DECREASES TO 25% OF  
INITIAL VALUE. (Ta=25°C)

\* Idc2: THE CURRENT WHEN THE TEMPERATURE OF COIL IS INCREASED BY 40°C. (Ta=25°C)

\* THE RATED CURRENT INDICATED THE SMALLER ONE BETWEEN Idc1 AND Idc2.

REMARK	SPEC. No. 3/4 <b>H500-0428</b>
--------	-----------------------------------

## 6. GENERAL CHARACTERISTICS

TYPE
------

\* STANDARD TESTING CONDITIONS:

UNLESS OTHERWISE SPECIFIED, THE STANDARD RANGE OF ATMOSPHERIC CONDITIONS FOR MEASUREMENTS

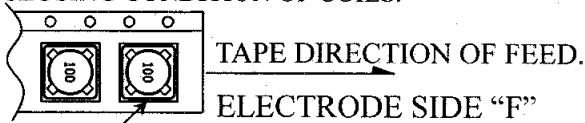
AND TESTS ARE AS FOLLOWS: AMBIENT TEMPERATURE: 15°C TO 35°C. RELATIVE HUMIDITY : 25% TO 85%. AIR PRESSURE : 86kPa TO 106kPa.

IF THERE IS ANY DOUBT ABOUT THE RESULTS, MEASUREMENT SHALL BE MADE WITHIN THE FOLLOWING LIMITS: AMBIENT TEMPERATURE: 20°C±1°C. RELATIVE HUMIDITY : 63% TO 67%. AIR PRESSURE : 86kPa TO 106kPa.

No.	ITEMS	CONDITIONS	SPECIFICATION
1	OPERATION TEMPERATURE STORAGE TEMPERATURE		-25 ~ +100°C (INCLUDING COIL TEMPERATURE RISE) -30 ~ +100°C
2	TEMPERATURE COEFFICIENT	-30 ~ 100°C	0 ~ 2000ppm/°C
3	FIXING STRENGTH	SAMPLE IS PUSHED IN THREE DIRECTIONS OF X, Y AND Z WITH THE FORCE OF 5.0N FOR 60±5 SECONDS. AFTER SOLDERING BETWEEN COPPER PLATE AND ELECTRODES.	NO ELECTRODE DETACHMENT.
4	RESISTANCE TO SOLDERING HEAT TEST	REFER TO STD-002NP.	NO MECHANICAL BREAKAGE. DEVIATION RELATIVE TO INITIAL VALUE: L: WITHIN ±5.0%
5	SOLDERABILITY TEST	IMMERSE THE ELECTRODE IN FLUX FOR 5 SECONDS THEN DIP THE T ELECTRODE INTO SOLDER BATH CONTAINING MOLTEN SOLDER AT 245±5°C FOR 2±0.5 SECONDS.	OVER 90% OF THE SURFACE BEING IMMersed SHALL BE COVERED WITH A NEW UNIFORM SOLDER.
6	VIBRATION TEST	AMPLITUDE: 1.5mm P-P FREQUENCY: 10~55~10Hz (1 MINUTE PER CYCLE) DARATION: 2 HOURS IN EACH OF X, Y, Z AXIS. (TOTAL 6 HOURS)	DEVIATION RELATIVE TO INITIAL VALUE: L: WITHIN ±3.0%
7	SHOCK TEST	PEAK ACCELERATION: 981m/s <sup>2</sup> DURATION OF PULSE: 10ms SHOCK TIMES: 3 TIMES IN EACH OF X, Y, Z AXIS. (TOTAL 9 TIMES)	DEVIATION RELATIVE TO INITIAL VALUE: L: WITHIN ±3.0%
8	HUMIDITY TEST	TEMPERATURE: 40°C±2°C HUMIDITY: 90%~95%RH DURATION: 96±4 HOURS.	DEVIATION RELATIVE TO INITIAL VALUE: L: WITHIN ±5.0%
9	HIGH TEMPERATURE LOAD LIFE TEST	TEMPERATURE: 100°C±2°C LOAD CONDITION: RATED CURRENT DURATION: 96±4 HOURS.	DEVIATION RELATIVE TO INITIAL VALUE: L: WITHIN ±5.0%
10	LOW TEMPERATURE LOAD LIFE TEST	TEMPERATURE: -20°C±3°C LOAD CONDITION: RATED CURRENT DURATION: 96±4 HOURS.	

## 7. PACKING

\* ENCLOSING CONDITION OF COILS.



\* PACKAGE TO BE ACCORDING TO PACKAGE SPECIFICATIONS (TICK THE RELEVANT "✓")

KB-CTR020;  KB-CTR630;  KB-CTR830;

SPECIAL FOR CUSTOMER KB \_\_\_\_\_

## 8. REMARK

\* NO WASHING AGENT.

\* RECOMMENDED REFLOW CONDITION BASES ON STD-001NP.

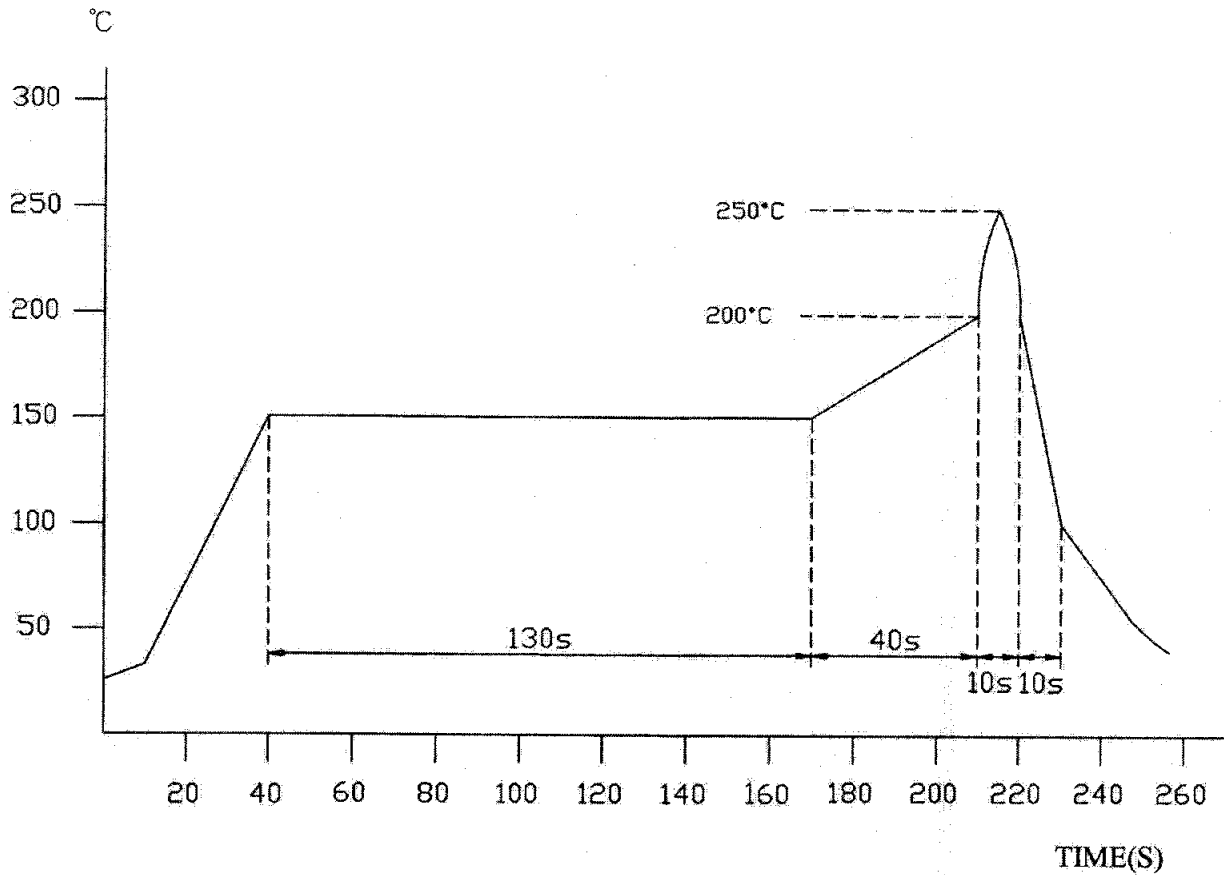
## 9. RoHS COMPLIANCE REMARKS

LEAD WILL BE PRESENT IN THE FERRITE CORE OF THE FRIT MATRIX IN THE COMPONENT. THIS USE, IS EXEMPT FROM ROHS LEGISLATION PER THE ANNEX (ITEM 7), WHICH REFERS TO "LEAD IN ELECTRONIC CERAMIC PART".

REMARK	SPEC. No. 4/4 <b>H500-0428</b>
--------	-----------------------------------

**THE RECOMMENDED REFLOW CONDITION (LEAD FREE)**

TEMPERATURE



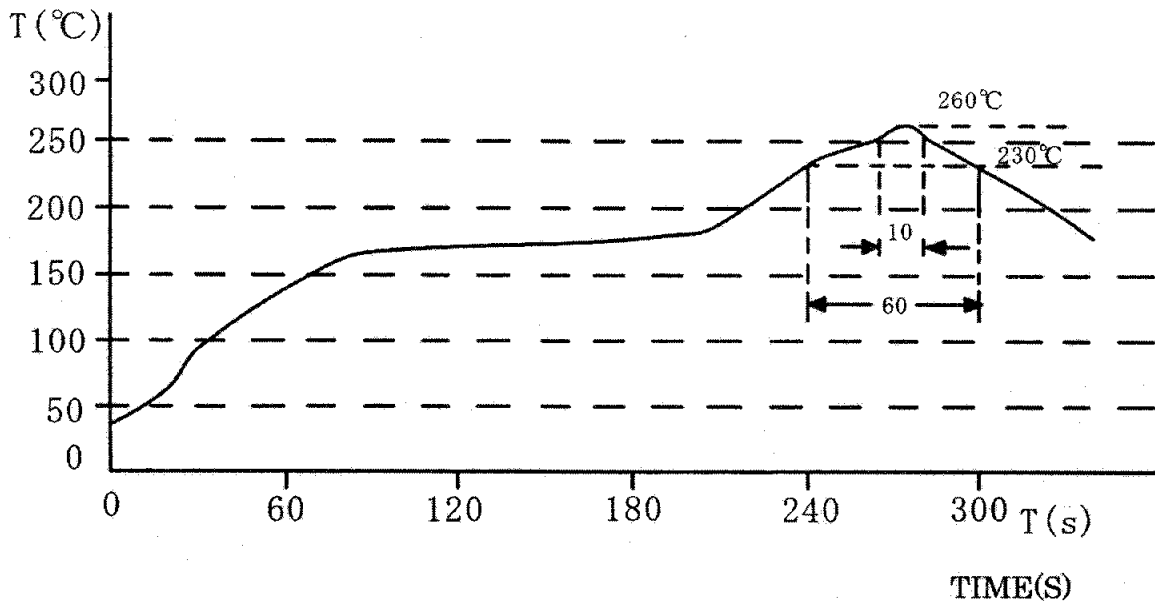
\* THE REFLOW CONDITION RECOMMENDED ABOVE IS ACCORDING TO THE MACHINE USED BY OUR COMPANY. BIG DIFFERENCES WILL ARISE AS A RESULT OF THE TYPE OF MACHINE, REFLOW CONDITIONS, METHOD, ETC USED. HENCE, BEFORE SETTING UP YOUR REFLOW CONDITIONS, PLEASE CONFIRM WITH THE ABOVE. MOREOVER, PLEASE CLEAR ALL DOUBTS WITH OUR COMPANY BEFORE STARTING.

25th, Feb.,2004			VERSIONS	1	25th, Feb.,2004	FILE No. 1/1  <b>STD-001NP</b>
APPROVAL	CHECK	PREPARE		2	9th, Nov.,2004	

COILS ELECTRONIC CO., LTD.

# HEAT ENDURANCE TEST (LEAD FREE)

TEMPERATURE



- \* THE TEST SHOULD BE MADE UNDER THE CONDITIONS ACCORDING TO THE CHART, AFTER THE TEST IT IS KEPT FOR 2 HOURS UNDER THE NORMAL TEMPERATURE AND HUMIDITY. THEN, NO MECHANICAL AND ELECTRICAL DEFECT SHOULD BE FOUND OUT.
- \* THE REFLOW TEST CAN BE DONE TWICE, BUT THE INTERVAL SHOULD BE MORE THAN ONE HOUR UNDER THE NORMAL CONDITIONS.
- \* THE REFLOW TEST CONDITIONS ARE BASED ON THE TESTING INSTRUMENTS AVAILABLE IN CEC.

25th, Feb., 2004			REVISIONS	FILE No. 1/1
APPROVAL	CHECK	PREPARE		<b>STD-002NP</b>

# PACKAGE SPECIFICATIONS

## 1. APPLICATION OF THIS SPECIFICATION

- 1) APPLIES TO CEC COILS ELECTRONIC CO., LTD. PACKING.
- 2) THE PACKAGE SHALL BE BASED ON INDIVIDUAL COIL SPECIFICATION UNLESS SPECIFIED IN THIS PACKAGE SPECIFICATION OR ANY DIFFERENCES BETWEEN THIS PACKAGE SPECIFICATION AND COIL INDIVIDUAL SPECIFICATION.

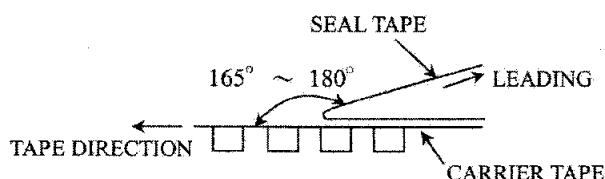
## 2. APPLICATION (TYPES): SD75、DRH74 $\triangle$

## 3. TAPING SPECIFICATION

- 1) REEL DIMENSIONS..... FIGURE 1
- 2) TAPE DIMENSIONS..... FIGURE 2
- 3) TAPE DIMENSION..... FIGURE 3

## 4. TAPING




- 1) THE CARRIER TAPE AND SHIELD TAPE IS WOUND IN ONE CONTINUOUS REEL WITHOUT ANY JOINTED PORTIONS. SHOULD ANY PIECE OF COIL BE MISSING FROM THE CARRIER TAPE, A "CROSS(X)" SLIT WOULD BE MADE ON THE SHIELD OF THE CARTRIDGE AND A COIL REPLACED. AFTER WHICH, CELLOPHANE TAPE IS USED TO RESEAL THE CATRIDGE.
- 2) THE ANGLE BETWEEN THE SEAL TAPE DURING PEELOFF AND THE DIRECTION OF B UNREELING SHALL BE  $165^{\circ}$  TO  $180^{\circ}$ . THE SEAL TAPE SHALL ADHERE UNIFORMLY TO THE CARRIER TAPE ALONG BOTH SIDES IN THE DIRECTION OF UNREELING. THE PEEL FORCE WITH A PEEL SPEED OF  $300\text{mm}/\text{MIN} \pm 10\text{mm}/\text{MIN}$  SHALL BE AS FOLLOWS:  
 0.1N TO 1.0N FOR AN 8mm TAPE WIDTH.  
 0.1N TO 1.3N FOR A 12mm~56mm TAPE WIDTH.



- 3) PRECAUTION: COMPLETED REELS WITH RADIUS LESS THAN 40mm WILL RESULT IN THE FOLLOWING
  - ( I ) CRACKS ON THE CARRIER TAPE
  - ( II ) SHIELD TAPE TEARING OFF

## 5. PACKING

- 1) POSITION OF COILS IN THE CARRIER TAPE: REFER TO THE SPECIFICATION OF THE INDIVIDUAL PART.
- 2) THERE SHOULD NOT BE:
  - ( I ) WRONG POSITION OF GOODS IN THE CARRIER TAPE
  - ( II ) REJECTED GOODS IN THE CARRIER TAPE
  - ( III ) MISSING GOODS FROM THE CARRIER TAPE
- 3) ONE REEL CONSISTS OF 1000 PIECES OF COIL.
- 4) ON THE COMPLETED END OF THE REEL, THE CARRIER TAPE IS FIXED WITH A DRIVING TAPE.

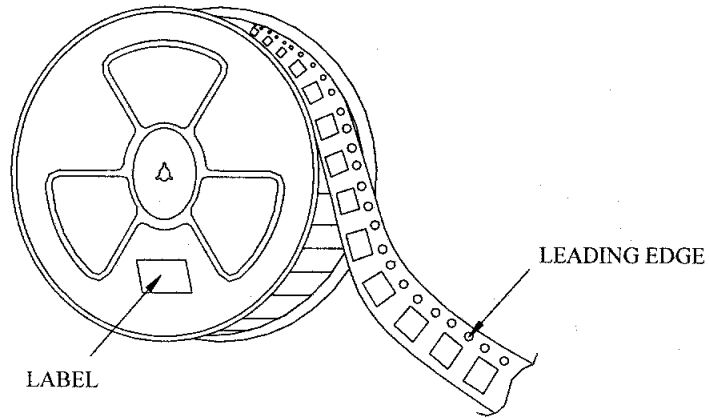
4th. Oct., 2001				
APPROVAL	CHECK	DESIGN		
			REMARK	PACKAGE SPEC. No. 2/5  <b>KB-CTR020</b>

**6. INDICATION**

1) THE FOLLOWING WILL BE INDICATED ON ONE SIDE OF THE REEL:

TYPE NAME	
CUSTOMER PART NO.	
SUPPLIER PART NO.	
SUPPLIER SPEC. NO.	
QUANTITY	
LOT NO.	

2) LABEL POSITION DESCRIPTION REFER TO THE FIGURE SHOWN BELOW:



**7. HANDING PRECAUTION**

THE SURFACE OF THE REEL CANNOT WITHSTAND A WEIGHT/FORCE EXCEEDING 9.8N.

**8. STORAGE**

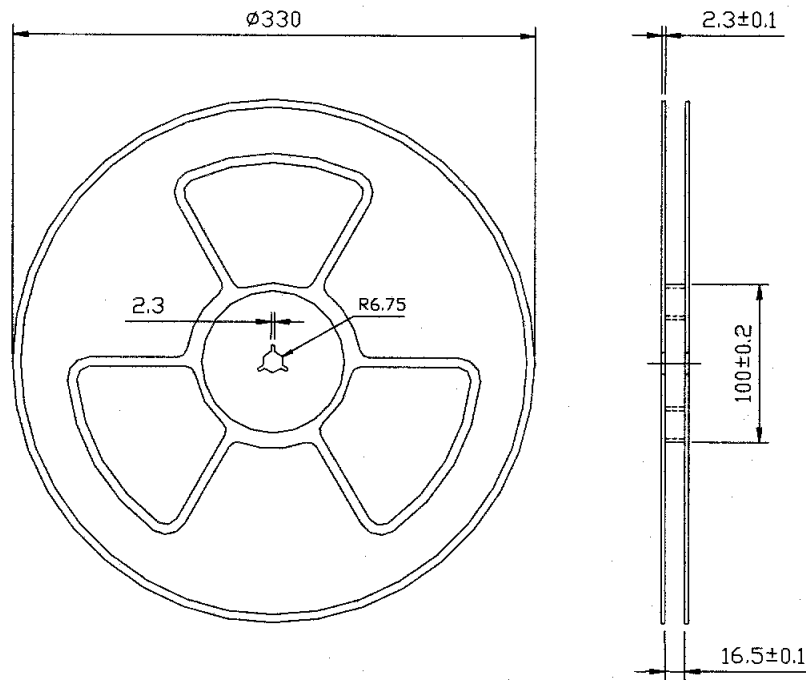
GOODS TO BE STORED UNDER TEMPERATURES LESS THAN 60°C, WITH HUMIDITY NOT EXCEEDING 90%. IF THE STORAGE PERIOD IS LONG, REEL SHOULD BE REWOUND.

**9. OTHERS**

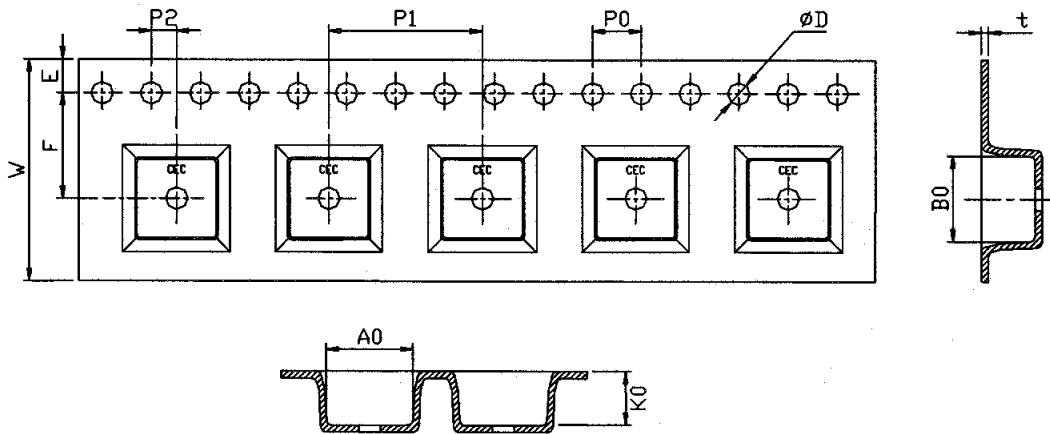
UNIT OF MEASURE USED WHEN PLACING ORDERS: REEL.

REMARK	PACKAGE SPEC. No. 3/5
	<b>KB-CTR020</b>

**FIGURE 1 REEL DIMENSIONS**



**FIGURE 2 TAPE DIMENSIONS**



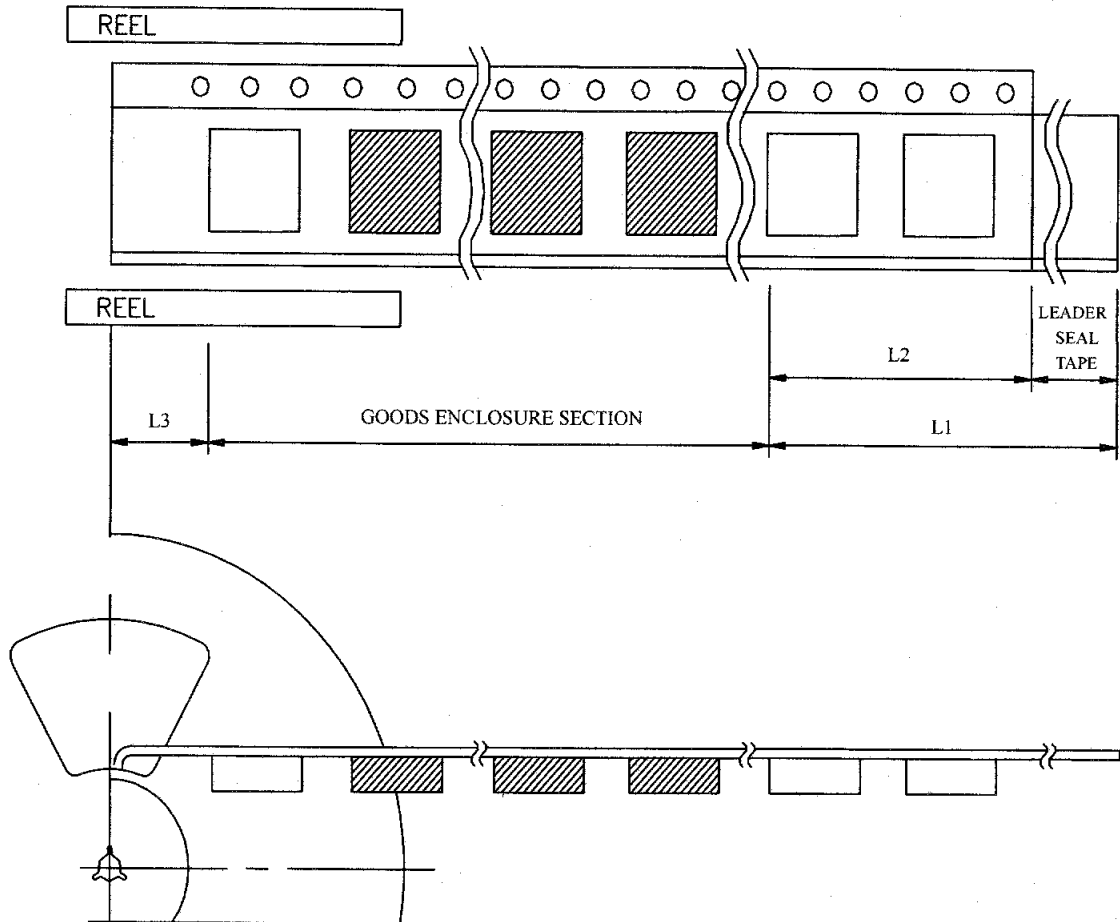
DIMENSIONS (UNIT: mm)											
SERIES	W	A0	B0	D	K0	E	F	P0	P1	P2	t
	$16 \pm 0.3$	$7.5 \pm 0.1$	$7.7 \pm 0.1$	$\phi 1.55 \pm 0.05$	$5.0 \pm 0.1$	$1.75 \pm 0.1$	$7.5 \pm 0.1$	$4.0 \pm 0.1$	$12 \pm 0.1$	$2.0 \pm 0.1$	$0.35 \pm 0.05$

REMARK	PACKAGE SPEC. No.	4/5
	<b>KB-CTR020</b>	

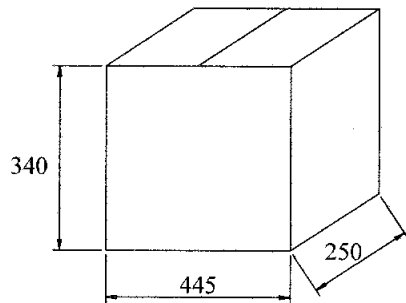


**FIGURE 3 TAPE DIMENSION**

L1	LEADER SECTION LENGTH	MIN. 400mm
L2	START CARRIER TAPE LENGTH	MIN. 100mm
L3	TRAILER SECTION LENGTH	MIN. 160mm
	QUANTITY	1000pcs



**10. OUTCARTON**



10 Reels/Carton Total 10,000 Pcs

REMARK	PACKAGE SPEC. No. 5/5
	<b>KB-CTR020</b>