

FEATURES:

- Ultra-Wide 4:1 input range
- Efficiency up to 88%
- Low power consumption 0.12W
- Continuous short circuit protection
- Meet EN55032 Class A with no external component needed
- Design to meet EN62368 and EN50155
- Operating temperature -40°C to + 85°C
- Remote on/off control
- Input/Output Isolation 1500VDC
- Over voltage & over current protection

Picture is coming soon

Models Single output



Model	Input Voltage (V)	Output Voltage (Vdc)	Output Current max (mA)	Isolation (VDC)	Max Capacitive Load (uF)	Efficiency (%)
AM10TW-2403S-NZ	9-36	3.3	2400	1500	1200	87
AM10TW-2405S-NZ	9-36	5	2000	1500	1000	88
AM10TW-2412S-NZ	9-36	12	833	1500	470	87
AM10TW-2415S-NZ	9-36	15	667	1500	330	87
AM10TW-2424S-NZ	9-36	24	416	1500	100	88
AM10TW-4803S-NZ	18-75	3.3	2400	1500	1200	86
AM10TW-4805S-NZ	18-75	5	2000	1500	1000	87
AM10TW-4812S-NZ	18-75	12	833	1500	470	87
AM10TW-4815S-NZ	18-75	15	667	1500	330	87
AM10TW-4824S-NZ	18-75	24	416	1500	100	88

Models Dual output

Model	Input Voltage (V)	Output Voltage (V)	Output Current max (mA)	Isolation (VDC)	Max Capacitive Load(uF)	Efficiency (%)
AM10TW-2405D-NZ	9-36	±5	±1000	1500	±1000	83
AM10TW-2412D-NZ	9-36	±12	±416	1500	±470	87
AM10TW-2415D-NZ	9-36	±15	±330	1500	±330	87
AM10TW-4805D-NZ	18-75	±5	±1000	1500	±1000	83
AM10TW-4812D-NZ	18-75	±12	±416	1500	±470	87
AM10TW-4815D-NZ	18-75	±15	±330	1500	±330	87

NOTE: All specifications in this datasheet are measured at an ambient temperature of 25°C, humidity<75%, nominal input voltage and at rated output load unless otherwise specified.

Input Specifications

Parameters	Nominal	Typical	Maximum	Units	
Voltage range	24V input models	9-36	40	VDC	
	48V input models	18-75	80		
Input Current (full load/no load)	24V, nominal input voltage	3.3V model	379/12	388/25	mA
		5V model	473/6	484/15	
		Others	502/5	515/12	
	48V, nominal input voltage	3.3V model	192/5	197/20	
		5V model	239/6	245/15	
		Others	251/4	258/8	
Input Reflected Ripple Current	24V nominal input voltage	40		mA	
	48V nominal input voltage	30			
Filter	π (Pi) Network				
Absolute Maximum Rating	24V input models, 1s max	-0.7-50		VDC	
	48V input models, 1s max	-0.7-100			
Peak Input Voltage time			1000	ms	
Input Under voltage turn off	24V input models	6.5		VDC	
	48V input models	15.5			
On/Off control	ON – High (3.5 ... 12Vdc) or open circuit; OFF – Low (0 ... 1.2Vdc) or Short circuit pin1 and pin 2/3 OFF idle current: 6.0 mA typical				

Isolation Specifications

Parameters	Conditions	Typical	Rated	Units
Tested I/O voltage	60 sec, <1mA		1500	VDC
Resistance	500VDC	>1000		MOhm
Capacitance	100KHz/0.1V	2000		pF

Output Specifications

Parameters	Conditions	Typical	Maximum	Units	
Voltage accuracy *	0%-100% load	3.3V/5V single output	±0.5	±2	%
		Others	±1	±3	
Cross regulation (Dual Output)	50% load on one output, 25%~100% load on second		±5	%	
Over voltage protection	Full input range		110~160	% of Vout	
Short circuit protection	Continuous, Auto recovery				
Over current protection	Full input range	3.3V/5V single output	110~230	% of Iout	
		Others	110~190		
Line voltage regulation	LL-HL, Full load	Positive output	±0.2	±0.5	%
		Negative output	±0.5	±1	
Load voltage regulation	5% Load to Full Load	Positive output	±0.5	±1	%
		Negative output	±0.5	±1.5	
Temperature coefficient	Full load		±0.03	%/°C	
Transient recovery time	25% load step change, 110Vin, 2250V Isolation	0.3	0.5	mS	
Transient recovery deviation	25% load step change	3.3V/5V single output	±5	±8	%
		Others	±3	±5	
Ripple & Noise **	20MHz Bandwidth	40	80	mV p-p	

* Voltage accuracy for models with 3.3V and 5V single output at 0%-5% load is ±3%. Voltage accuracy for ±5V dual output model at 0%-5% load is ±5%.

** Ripple and Noise at 0%-5% load ≤5% Vout. Please refer to the application note for specific details.

General Specifications

Parameters	Conditions	Typical	Maximum	Units
Switching frequency	100% load	350		KHz
Operating temperature	Full Load with derating above 65°C	-40 to +85		°C
Storage temperature		-55 to +125		°C
Maximum case temperature			105	°C
Cooling	Free air convection			
Humidity			95	% RH
Case material	Aluminum alloy			
Weight		12		g
Dimensions (L x W x H)	1.26 x 0.79 x 0.43 inches 32.00 x 20.00 x 10.8 mm			
MTBF	>1 000 000 hrs (MIL-HDBK -217F, Ground Benign, t=+25°C)			
Manual soldering temperature	1.5mm from case for 10 sec		300	°C

Environment Specifications

Test	Parameters	Conditions
Vibration	EN50155	IEC/EN 61373 Category 1, class B
	EN62368	10-150Hz, 5g, every axis tested

Safety Specifications

Parameters		
Agency approvals	CE, UL pending	
Standards	EMI - Conducted and radiated emission	CISPR32 / EN55032 Class A, without external circuit CISPR32 / EN55032 Class B, with the EMC recommended circuit part B EN50121-3-2, with the EMC recommended circuit part B EN55016-2-1, with the EMC recommended circuit part B
	Electrostatic Discharge Immunity	IEC61000-4-2, Contact ±4kV, Criteria B EN50121-3-2, Contact ±6kV/ Air ±8kV, Criteria B
	RF, Electromagnetic Field Immunity	IEC61000-4-3, 10V/m, Criteria A EN50121-3-2, 20V/m, Criteria A

Electrical Fast Transient/ Burst Immunity	IEC61000-4-4, $\pm 2kV$ with the EMC recommended circuit part A, Criteria B EN50121-3-2, $\pm 2kV$ with the EMC recommended circuit part A, Criteria A
Surge Immunity	IEC61000-4-5, L-L $\pm 2kV$ with the EMC recommended circuit part A, Criteria B EN50121-3-2, L-L $\pm 1kV$ with the EMC recommended circuit part A, Criteria A
RF, Conducted Disturbance Immunity	IEC61000-4-6, 10Vrms, Criteria A EN50121-3-2, 10Vrms, Criteria A
Voltage dips, short interruptions, and voltage variations immunity	IEC61000-4-29, 0%-70%, Criteria B

Derating

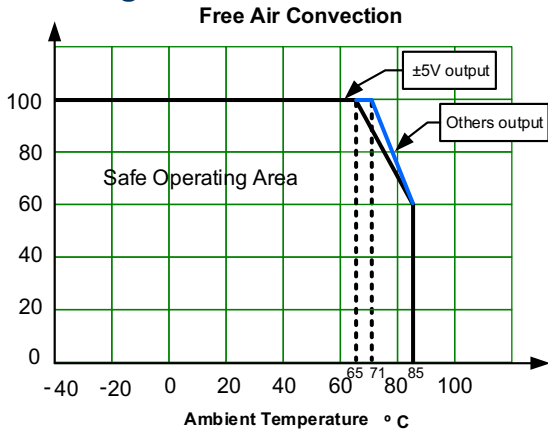

Dimensions

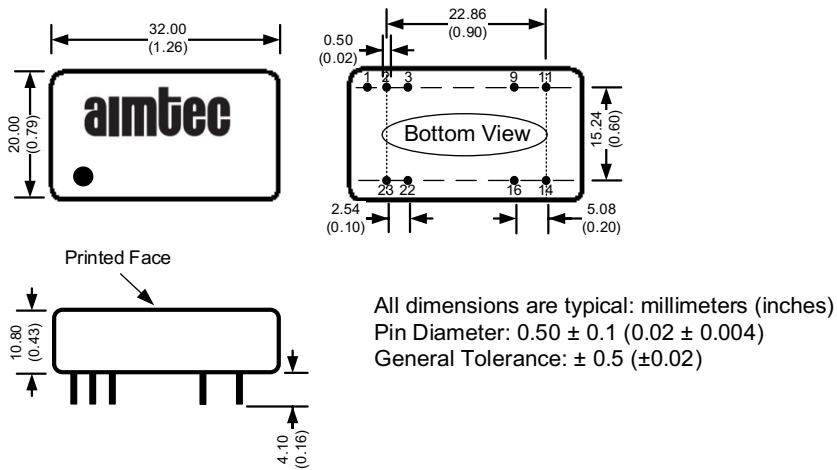

Pin Out Specifications

Pin	Single	Dual
1	Remote On/Off	Remote On/Off
2	-V Input	-V Input
3	-V Input	-V Input
9	No Pin	Common
11	N.C.	-V Output
14	+V Output	+V Output
16	-V Output	Common
22	+V Input	+V Input
23	+V Input	+V Input

Typical application circuit

Single output models

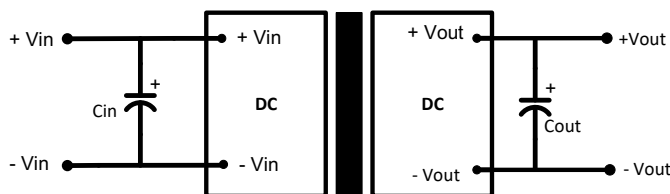

Dual output models

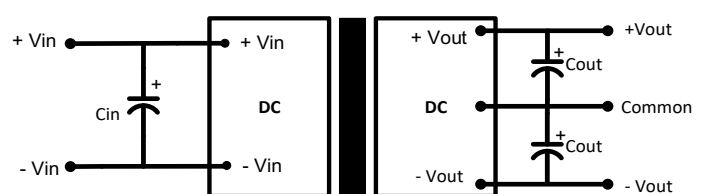

Vin	Cin	Cout
24V	100 μ F	10 μ F
48V	10-47 μ F	10 μ F

EMC Recommended Circuit

For 3.3V/5V single output models

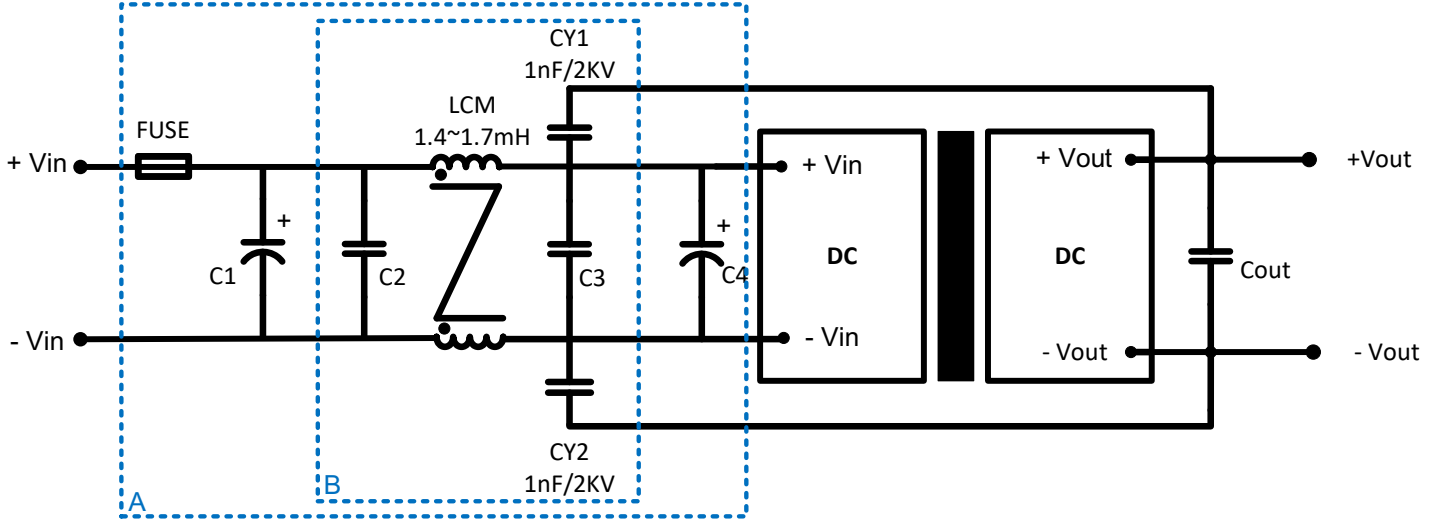

For other models

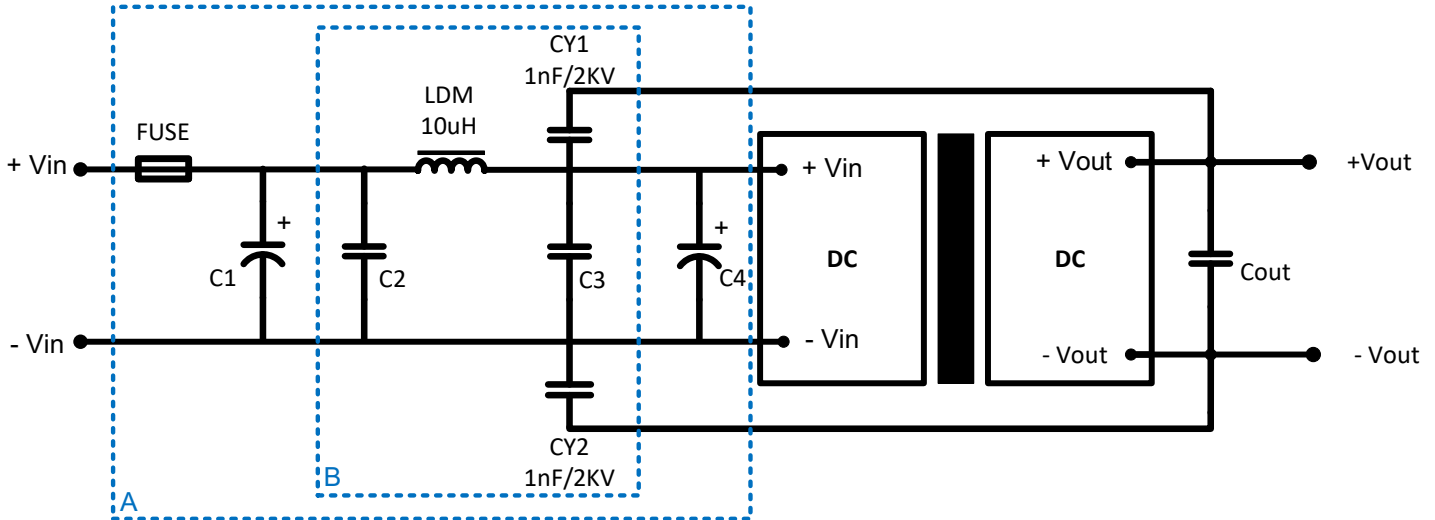

Part A for EMS. Part B for EMI.

Model	24V	48V
FUSE	Choose based on actual current	
C1, C4	330 μ F/50V	330 μ F/100V
C2, C3	10 μ F/50V	10 μ F/100V

NOTE: 1. Datasheets are updated as needed and as such, specifications are subject to change without notice. Once printed or downloaded, datasheets are no longer controlled by Aimtec; refer to www.aimtec.com for the most current product specifications. 2. Product labels shown, including safety agency certifications on labels, may vary based on the date manufactured. 3. Mechanical drawings and specifications are for reference only. 4. All specifications are measured at an ambient temperature of 25°C, humidity<75%, nominal input voltage and at rated output load unless otherwise specified. 5. Aimtec may not have conducted destructive testing or chemical analysis on all internal components and chemicals at the time of publishing this document. CAS numbers and other limited information are considered proprietary and may not be available for release. 6. This product is not designed for use in critical life support systems, equipment used in hazardous environments, nuclear control systems or other such applications which necessitate specific safety and regulatory standards other than the ones listed in this datasheet. 7. Warranty is in accordance with Aimtec's standard Terms of Sale available at www.aimtec.com.