

Hangzhou NeoDen Technology Co.,Ltd



User Manual

Neoden4

Content

1. NeoDen4 Introduction.....	1
1. 1. Brief Introduction.....	1
1. 2. Structure of NeoDen 4.....	1
2. Operation Flow Chart.....	2
3. Procedure for making a programming file.....	3
4. Edit on the Operation Interface.....	3
4. 1. Edit on the Interface.....	3
4. 3. 1. PCB Feeding Setting.....	4
4. 3. 2. Setting Panelized PCB & first chip.....	4
4. 3. 3. PCB mark point setting.....	6
4. 3. 4. Component list settings.....	8
4. 3. 5. Feeder configuration.....	10
4. 2. File Mounting.....	14
4. 3. Manual Test.....	15
4. 3. 1. Placement head.....	15
4. 3. 2. Rail control.....	16
4. 3. 3. Hose control.....	16
4. 3. 4. Feeder test.....	17
4. 4. Factory settings.....	17
4. 4. 1. Feeder configuration.....	19
4. 4. 2. Feed setting.....	22
4. 4. 3. Peel Configuration.....	23
4. 4. 4. System setting.....	24
4. 5. First trial and testing.....	26
4. 6. Continuous SMT production.....	27
5. Structure and maintenance instruction.....	27
5. 1. Structure chart.....	27
5. 1. 1. Peel-box.....	28
5. 1. 2. Tape&Reel holder.....	29
5. 1. 3. Fixation support.....	29
5. 1. 4. Feed-box.....	30
5. 1. 5. Vibration feeder.....	30
5. 1. 6. Auto-rails.....	31
5. 1. 7. Nozzle.....	31
5. 2. Maintenance.....	32
5. 2. 1. Take effective measures to reduce/ avoidmalfunction.....	32
5. 2. 2. Maintenance of device.....	33
5. 2. 3. Placement failure analysis and trouble shooting.....	34
5. 2. 4. Related issues during Solder paste printing process.....	36



PLEASE READ THIS USER MANUAL COMPLETELY BEFORE OPERATING THIS UNIT AND RETAIN THIS BOOKLET FOR FUTURE REFERENCE

Notes

1. The contents include all features of NeoDen4, some of which may not be equipped on your machine.
2. Basic training and basic SMT knowledge is required for an operator.
3. For routine inspection and repair ,please contact sales for operating instruction.

Safety Device,Warning Label

1. Before operation,please ensure the presence of adequate guarding and safety devices to avoid accident..
2. When teardown the safety device,please keep it in the original position,and make sure it works in good condition
3. When failures happen on safety device,can not run the machine after remove safety device.In case any injuries or casualty accident

Usage

1. You agree that you will solely be responsible for your use of any products and services provided to you and that you will use our products and services legally and only for the purposes that they are intended to be used for.
2. You agree that you will not misuse the products and/or services supplied and that you will abide by any laws applicable to this agreement or the operation of it.

CAUTION

Power off: After cut off main power supply,pull the plug or disconnect the power cable from the power supply.

1. When an exception or failure happens,or power failure,please terminate the operation of Windows,and power it off.
2. Power off prior to cleaning and repairing in case of any accidents.
3. When pull the plug,please hold the head instead of wire.

Transport

1. Take necessary security measures,to prevent upside down or fall when lifting or moving.

Open

1. Please read all instruction in the wooden box
2. Do not cut the packing tape by knife,to avoid scratch the machine
3. Keep all packing material.

Installation

1. Please put the machine in a horizontal place.
2. Please keep the floor clean and dry,and the machine should be grounded, to prevent electric shock or leakage.

Prepare work

1. Make sure the power cable no damage,no shedding and no loose.
2. Do not put hand in the working area.

Maintenance

1. Repair and calibration should be operated by skilled mechanical technician.When replacing parts,please use the part which are supplied by NeoDen.We are not responsible for any accident result from using nonstandard part.
2. In order to prevent electric shock caused by unskilled operation,the electrical repairs, maintenance(including wiring),should be operated by professional electrician or the technical staff from NeoDen or our distributors.
3. Make sure Bolts - Nuts are tighten after repair,calibration or replacing any part.

Working Environment

1. Do not use machine in a noisy environment,such as high frequency welding machine.
2. Do not use machine if the power supply voltage exceed the rated voltage $\pm 10\%$.
3. Do not use machine and pull the plug when thunder to avoid any accident caused by damaged electrical component.

1. NeoDen4 Introduction

1. 1. Brief Introduction

The fourth generation model NeoDen4 is NeoDen Tech’s independent product, with completely independent intellectual property. Its high precision vision system made it stand out in desktop pick and place machine area.

Vision system pick and place machine NeoDen4, with high speed and accuracy, compact in body, low power, stable quality and easy operation. It adopts our newly developed feeding system which can help to replace the tape easily and install smoothly, together with its vision system and rails feeding system, committed to create the great value for customers in actual PCB production.

NeoDen4, the 4th generation pick and place machine of NeoDen Tech., was independently designed and developed with patents and CE certificate.

This machine is adopted dual cameras, four heads, auto rails, electronic feeder, two conveyor ports, which achieves high accuracy, simple structure, stable performance and easy operation.

1	Number of Heads with	Neoden 4
2	Placement Rate(under factory test condition)	WITH VISION:5000/WITHOUT VISION:10000
3	Feeder capacity	TAPE REEL FEEDERS:48 (all 8mm)
		VIBRATING FEEDERS:5
4	IC tray capacity	5
5	Component sizes with vision	Smallest Component size:0201
		Largest Component size:TQFP240
6	Component Max Height	5MM
7	Resolution	X/Y axis:0.01MM Z axis:0.1MM
9	Rotation	+/-180°(360°)
10	Positioning Accuracy	+/-0.02MM
11	X-Y repeatability	+/-0.02MM
13	Placement Area	Without waffle Tray: 310*1500MM
		With 1 waffle Tray: 140*1500MM
15	Main Control	GUI
16	Power Supply	110V/220V
17	Power	180W

1. 2. Structure of NeoDen 4



- ①: Placement head
- ②: Nozzle
- ③: Rails
- ④: Vibration feeder
- ⑤: On/Off button
- ⑥: Conveyor port
- ⑦: Multi-hole positioning board
- ⑧: Feed box
- ⑨: Peel box
- ⑩: Emergency button
- ⑪: Power switch
- ⑫: Rack shelf
- ⑬: Acrylic cover
- ⑭: Foot Mounts
- ⑮: Fixed support

Each part mentioned above can be disassembled and tested. Please find more details on P20.

2. Operation Flow Chart

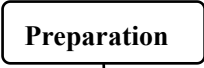
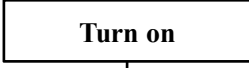
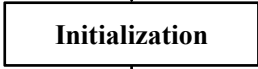
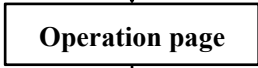
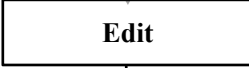
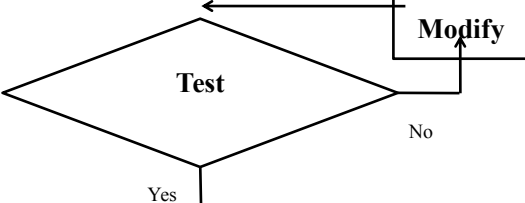
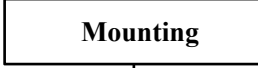
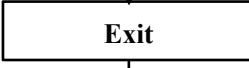
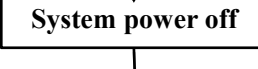
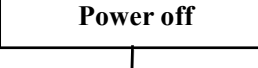
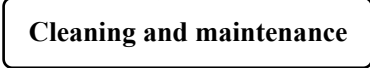
NO.	Flow chart	Note
1		Check the working environment whether it is safe or not
2		
3		The machine will start a 1-2 mins self-inspection after boot-up. It enters the operation page once finished. Need to wait 1-2 minutes after turn on the machine, mounting head will move diagonally and then enter into operation page
4		
5		Please check detailed programming tutorial in P? . Instructions please refer to the following pages
6		After making a programming file, there may exist several unpredictable problems , such as rotation issues of components, so a production testing is necessary for solving issues.
7		Start to pick and place
8		
9		Power off software
10		Power off after the software being turned off, which decrease the damage to the software
11		Keep the machine clean and nozzles need to be washed regularly Keep daily maintenance of nozzle assures high utility.

3. Procedure for making a programming file

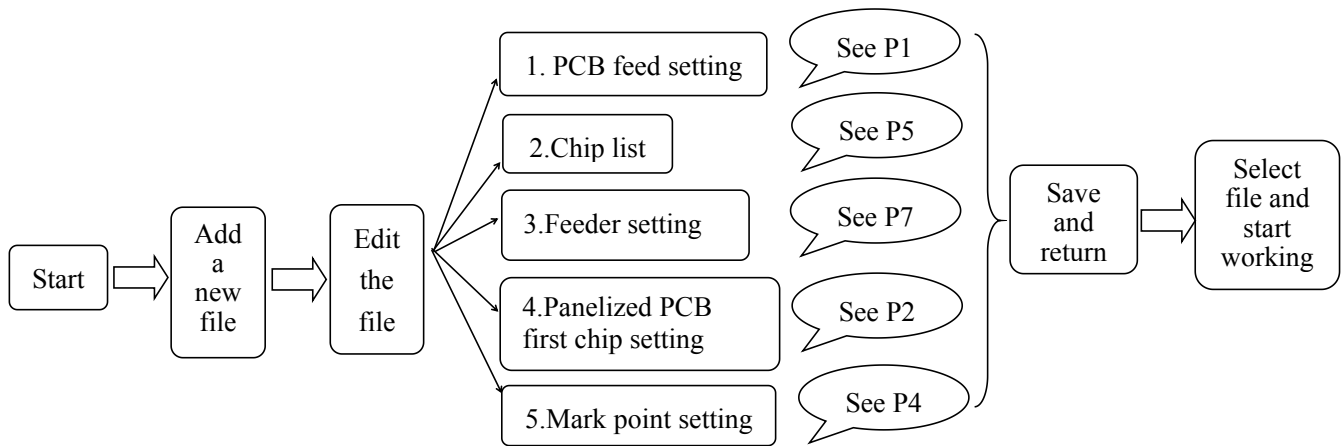

Note: The basic procedure of making a programming file for manual programming or direct PCB file is similar, but there are two different parts: chip list and mark point setting. Please find the detailed operation steps of the differences on relative page.

4. Edit on the Operation Interface

4. 1. Edit on the Interface

See below Fig.: Edit Interface

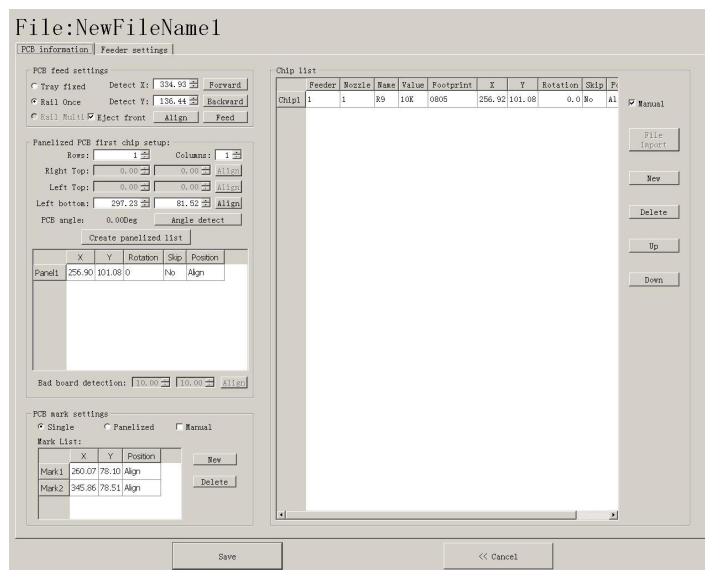

4.3.1. PCB Feeding Setting

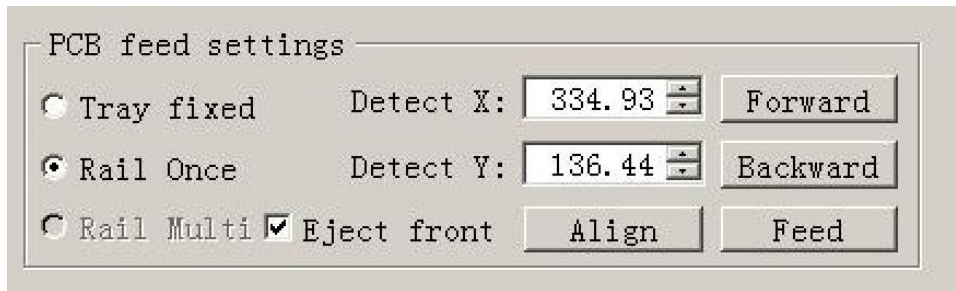

Function: Used to confirm the feeding place, first edit item in manual program

Introduction of function keys:

1. Tray Fixation: Once selected tray fixation, the setting items of board feeding will be closed. We only need use the positioning column to fix the board.
2. One-off rail feed: First need ensure there are rails for your machine, then select one-off rail feed, the setting items will be open corresponding.

Operation Step: First should adjust the width of the rail to ensure the PCB can move smoothly

- ① Adjust the position of the board in rail via clicking items "Rail forward" and "Rail backward".
- ② Click "Position Align" and into below interface (See fig.2), then adjust the position of camera until to the limited place by clicking the image (See fig.3). Click "Save" item to save the setting, return to the main page to finish the setting.

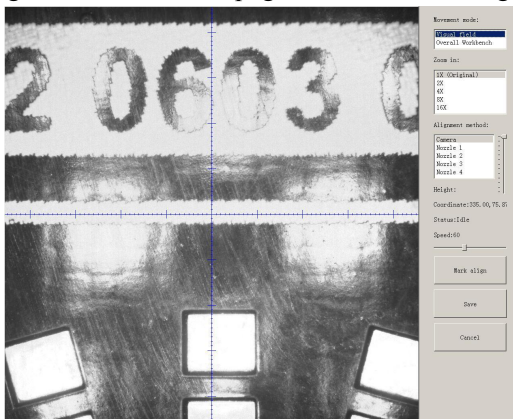

Fig.2

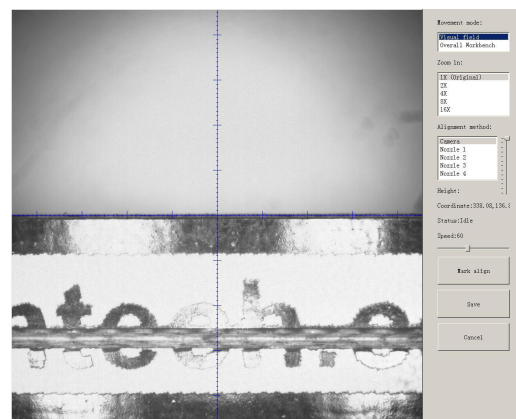
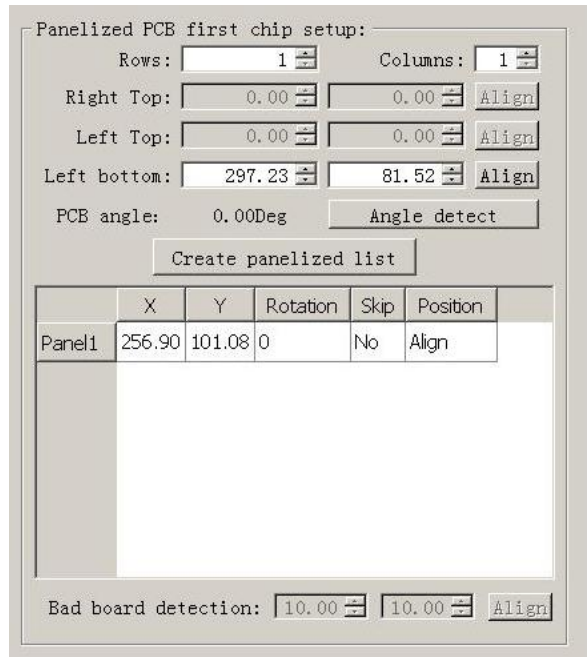

Fig.3

3. Multiple rail feed: This is only available for long board that can't be handled once, such as LED strip. After finished one part of PCB, the rails will advance the board and handle the left part automatically.
4. Eject PCB front-side: Once selected this item, the PCB will eject at front side when finish mounting. If don't select, the PCB will eject at back side.

4.3.2. Setting Panelized PCB & first chip

(manual is the same as automatic download)



Function: This is mainly to determine the first component on single or panelized PCB of manual programmed or imported file. The principle is to collect and calculate the data of each board's relative spacing, in order to achieve the effect of the actual placing.

Operation introduction

1. Single PCB: Only need to enter “1” in the row and column, some other useless function will turn grey. The “left bottom” is functional, which means the first PCB. Then you can press “align” to go to the screen of vision and get the coordinate of first component, see image 2-2.

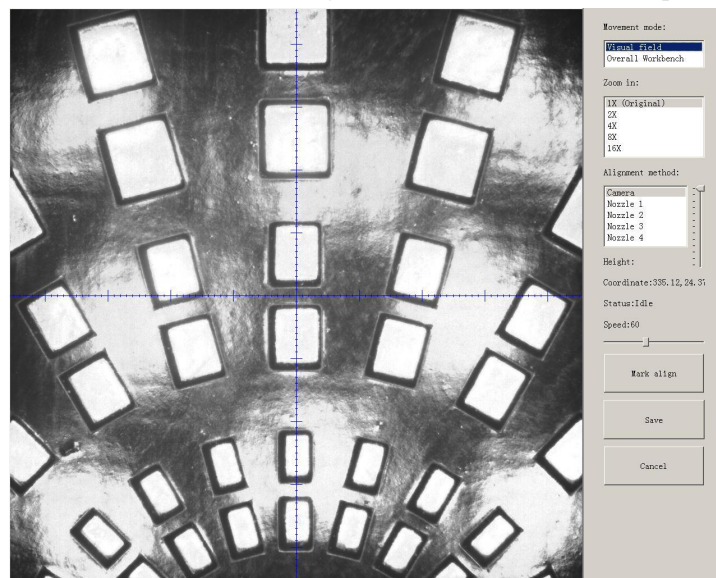

Fig.2-2

After saving the coordinate, the screen will automatically turn back to “PCB information”. Click “Create panelized list” to get the information of “Panel 1”. Now we’ve finished setting of first component of PCB.

2. Panelized PCB: the sequence is same to single PCB, but please pay some attention to several points below.

① The row and column is determined by the positioning of PCB on working area. The direction

along the rails is the column. Enter data in the row and column.

② About the data collection of “left bottom”, “left top” and “right top”, we should take the “left bottom” as the basic, and then go to set “left top” and “right top”. Once all the data is collected, the machine can calculate and process the information of panelized PCB. Please refer to the data collecting method of each position information as following

- The data of “left bottom” is collected according to first component in programming file. Press “align” find the left bottom panel which is nearest to the feeding position, after saving the data, it will return to the “PCB information” automatically.
- The data of “left top” is collected according to component (its position is same to that on “left bottom”). Press “align” find the left top panel which is furthest to the feeding position, after saving the data, it will return to the “PCB information” automatically.
- The data of “right top” is collected according to component (its position is same to that on “left bottom”). Press “align” find the right top panel which is furthest to the feeding position, after saving the data, it will return to the “PCB information” automatically.

After setup, click “create panelized list”, the data will be generated accordingly in the blank.

PCB angle correction

Bad board detection

3. PCB angle correction: angle deviation of PCB board compare to rails
4. Bad board detection: used for find the bad PCB board and skip

4. 3. 3. PCB mark point setting

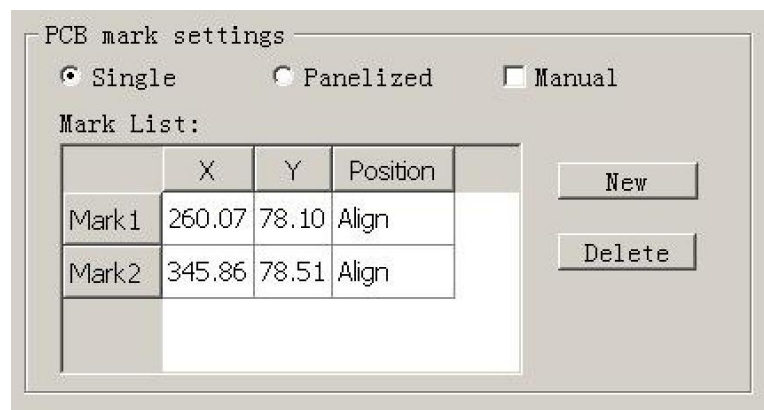

Fig.3-1

Function: After completing setup of the mark points, with which the machine can locate the position of PCB and identify the set up mark points, so that the next step can be followed

Operation method:

1. Mark point on single PCB: this mainly applies on single PCB or a whole board that consists of a few boards (take them as a single board).General we need to set 2-3 mark points.
2. Penalized PCB: this mainly applies on multiple PCB(we need to set mark points on each PCB)
3. Manual alignment: if there is no mark point on PCB, you can use some positioning holes or some other referential points as subsidies to locate the PCB.

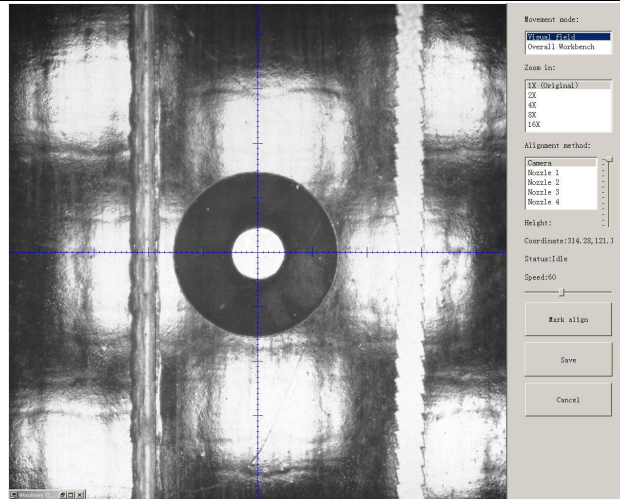

Fig.3-2

Import coordinate: according to the PCB schematic, we get the coordinate of mark and write down manually.

Mark point information;

Min-Max: Based on different size of mark point to find the correct position in case of any confusion.

Light source: inner ring and outer ring. Use inner ring if the board holes work as fiducials, use outer ring if light-spots work as fiducials.

Brightness: Default value

- Manual programming: when it's in Manual Programming status, the function "Alignment" of Mark will be effective. Click on it, the camera will go and collect the coordinate of mark (see image 3-2), save it and go back. (Note: if the mark point is far away, please use Overall movement to find it)
- No mark exists: Generally we will choose a component that is far away from the first component as a mark, which will make placement effect better.

4. Add mark point: the function of adding mark point

Delete mark point: the function of deleting mark point can be used when there is needless mark point or error point.

4.3.4. Component list settings

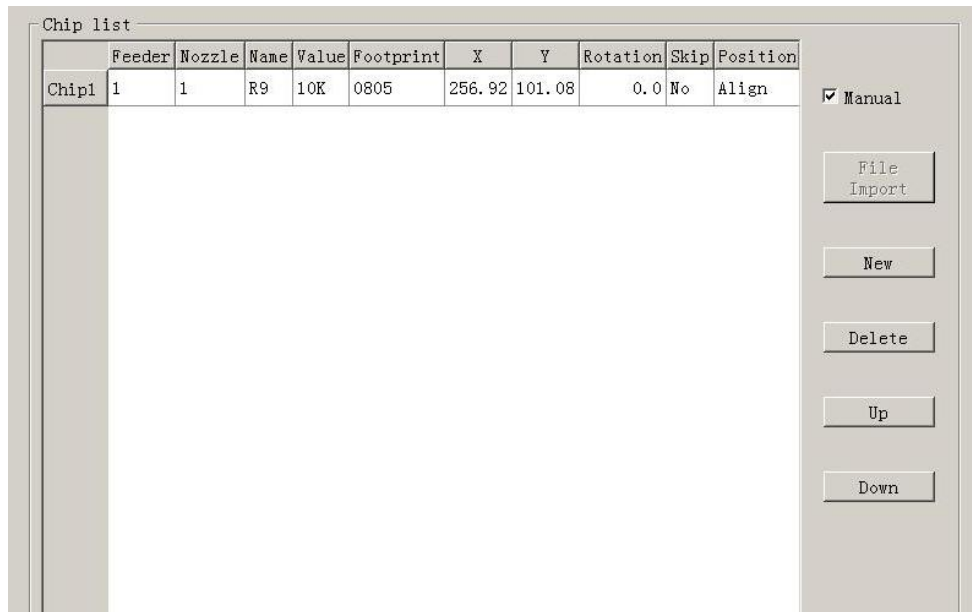

Function: to display the sequence, footprint and other information of components. There are two ways to add these information: manual programming and import mounting file.

Operation:

1. Manual programming: firstly, check the box of manual programming

There is a sample line of the first component, please modify this line firstly.

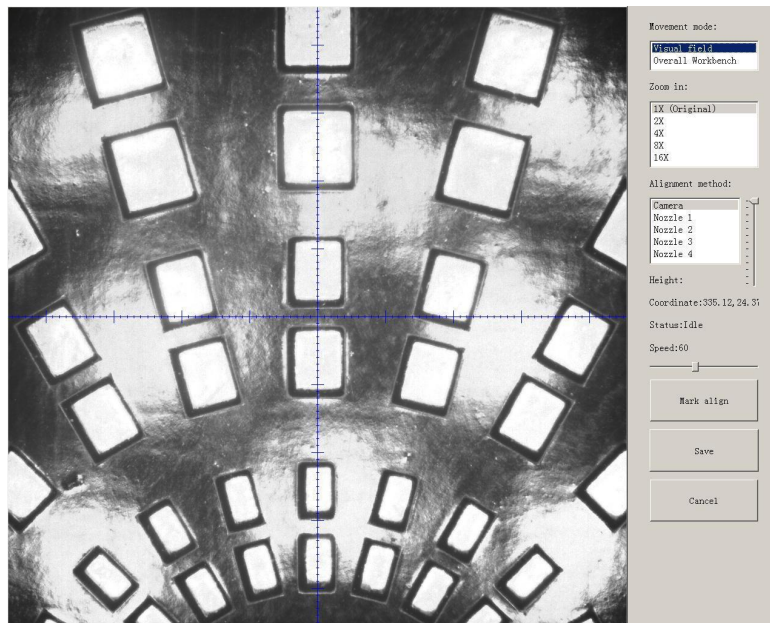

Fig. 4-1,
one component has been found

Find and confirm one component's coordinate by using the function of "Movement Mode"-Click to move (Visual field/Overall Workbench).Once clicked the "Save" item,the interface will automatic back to main page,then input the corresponding values(Designator refer to the location,Specification refer to the value of resistance,Footprint refer to the normal package

info, I.e. 0603, 0805, 1206, Etc. Angle value should be set according to the required direction on the PCB and polarity, horizontal direction (0 or 180 degree), vertical direction (90 or -90 degree). The value should be integer. The first component has been completely created after setting all the above values. The next step is to click “New” item and will popup one line (completely copy the previous line), then click “Align” to find and confirm second component (same operation as before)

2. Import PCB BOM File

- ① First generate the coordinates from PCB diagram and put the PCB file on the USB Flash Disk, then insert it to the machine (There are many kinds of PCB designer software, the only request is can generate the coordinates from them, file format (.csv)-support use Excel to edit
- ② Remove tick mark before the item “Manual Program” and then click “Import PCB BOM File”, will popup one small dialog, select the required PCB file and then click “Save” item, all data will be automatically imported to Chip List. (Turn to the “Feeder configuration” interface to do next operation). See fig.4-2

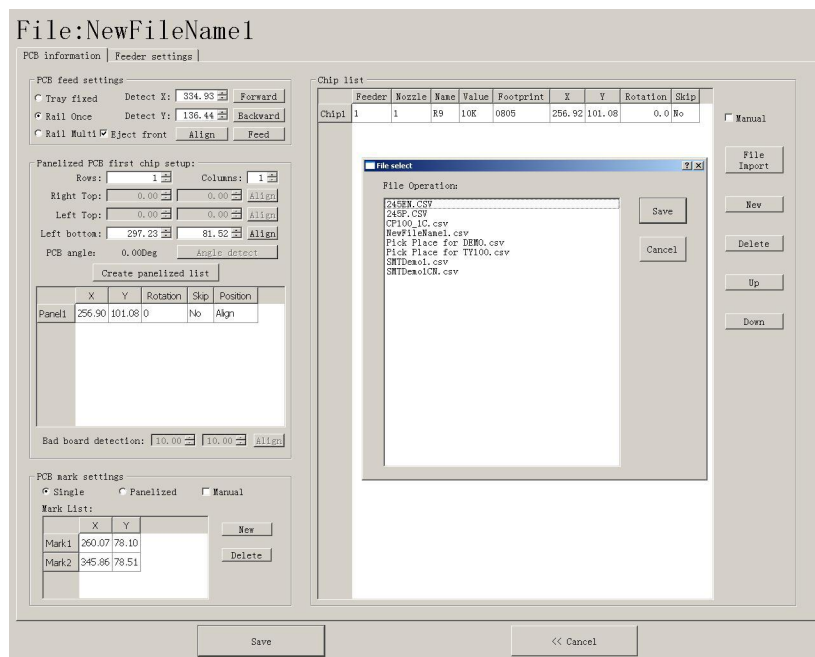
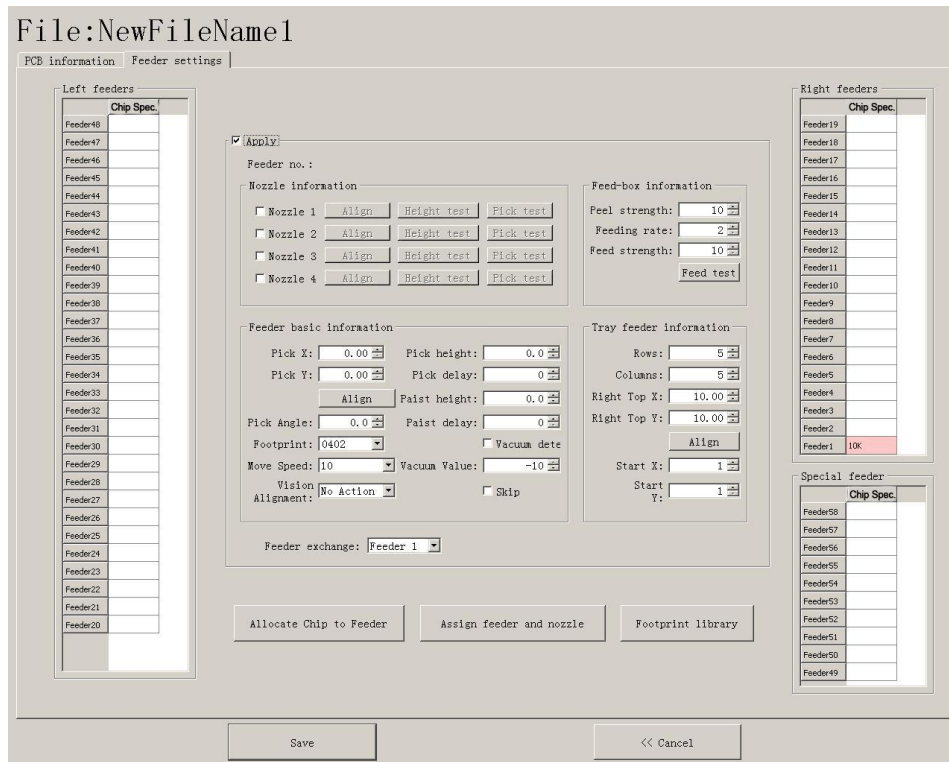
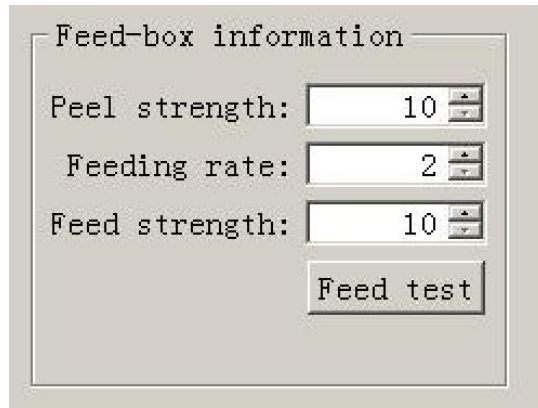

Fig.4-2

4.3.5. Feeder configuration



1. Feeders Arrangement: Left Feeders(Feeder20-48), Right Feeders(Feeder1-19), Special Feeders(Feeder49-58). Above feeders' setting is under the ideal situation. According to the Required Tape's width from customers, the quantities maybe be cut down. For example, if there are a lot of components' information under the "Chip List" item, choose the feeder number and you will find the drop-down symbol, will display all components' specifications by click it. Select one specification and one less in drop-down list, can do same operation in every feeder.
2. Feeder Configuration: Select one feeder, tick the item "Apply", all configurations will be unlocked for this feeder, then can do amendment. Total have five items: Nozzle information, Feed-box information, Feeder basic information, Tray feeder information, Feeder exchange. One item will be always locked for Feed-box information and Tray feeder information according to the differences of components. Operation sequence: Feed-box information(Tray feeder information)—Feeder basic information—Nozzle information—Feeder exchange(used if placed wrong tape).
 - Feed-box information setting



Function: Adjust the value for feed and peel box

Peel Strength: Support do adjustment according to different components' required strength, default value 100

Feed rate: Adjust the feed & peel distance by changing the value

Feed strength: Adjust the feed strength by changing the value, default value 60

Feed test: After finishing above steps, can click this item to test the feed status

- Tray feeder information

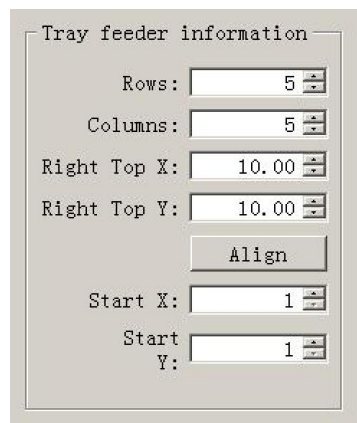

Function: Use to set the components' information from tray and tube packages, complete picking up operation for special feeders by changing the values

- ③ Column: Quantity of components on each column
- ④ Row: Quantity of components on each row
- ⑤ Right top X/Y: Find the position of right top component, this component is usually the last component in IC tray, and left bottom side is the first component in IC tray.
- ⑥ Start X/Y: This setting is used to define the position of 1st component, its default setting is X1,Y1(in 1st column, 1st row). If the 1st component is on 2nd column, 1st row, you can enter X2,Y1.

- Feeder basic information

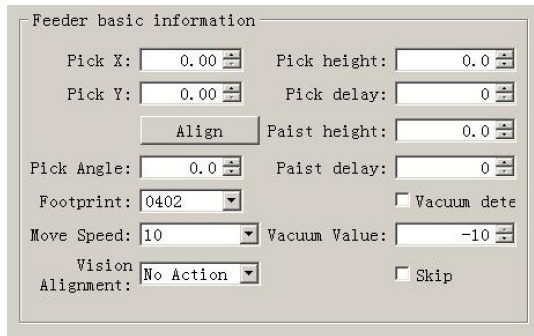

Fig.5-1

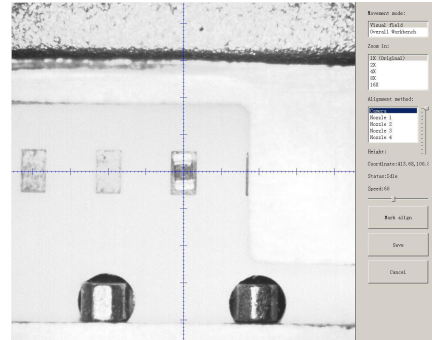
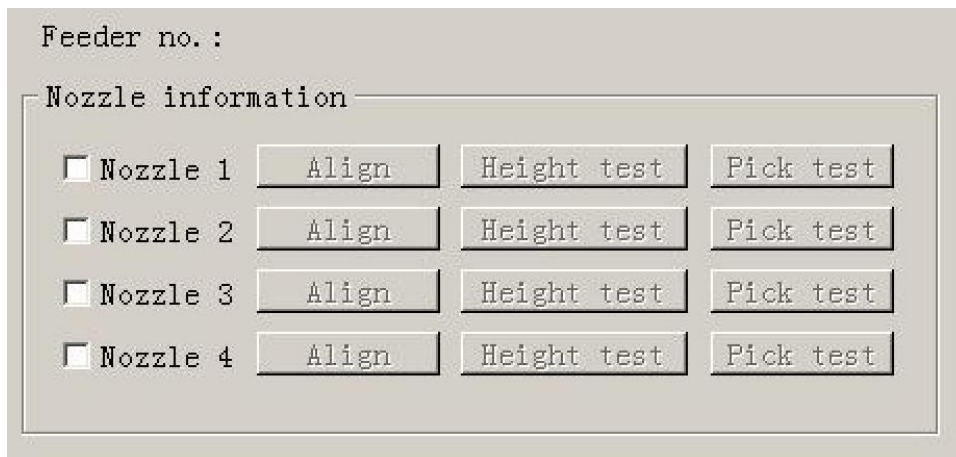

Fig.5-2

- ① Pick position X/Y: First have to lock the position of component on the feeder (See fig.5-2), once saved the modification, the XY date will automatically change to the ones after alignment.
- ② Pickup Angle: The initial default angle is 90 degrees, support to do modifying the value in order to change the mounting angels for wholly feeder if needed.
- ③ Footprint: Select corresponding footprint, when use the function "Vision Alignment", will refer to the values in date base.
- ④ Placement speed: Control the placement speed for the feeder by adjust the speed values.
- ⑤ Vision Alignment: Choose corresponding alignment method under this item.
- ⑥ Pick height: Control the pick height by dragging the sideward slider. Placement height: Set the value according to the component's actual thickness.
- ⑦ Placement/Pick delay: set a little value or 0 both ok.
- ⑧ Total have two detection methods, Vacuum Detection and Vision Detection. Vacuum Detection: Once set one vacuum value which help judge if qualified or not before placement. Once the actual vacuum won't reach this range, the machine will drop away this components and re-pick one.
- ⑨ Pet-name ruby chose this material after skip pasted on the station all the material will be skipped, generally will not choose.
Skip: Once select this item, will skip all placement for this feeder.

● **Nozzle Information**



Function: Select corresponding nozzles (one or more than one all acceptable) according to the components and the nozzle have set on the machine, then the machine will automatic assign to each feeder in order to meet the requirements **pf** single head work or multi heads working together. Also have detect functions on this item.

- Position Align: The nozzle will align to the component's upside on corresponding feeders when click this item
- Height Test: After clicking this item, the nozzle will go down and check whether the pick height is ok. Support do adjustment of pick height on feeder information item if needed.
- Pick test: After clicking this item, the corresponding nozzle will pick one component and check whether pick position is ok. Support do adjustment of pick position on feeder information item if needed.
- After finish setting of all above feeders information, then click "assign feeder and nozzle to Chip list", then chip list will automatic to be changed correspondingly.

4.2. File Mounting

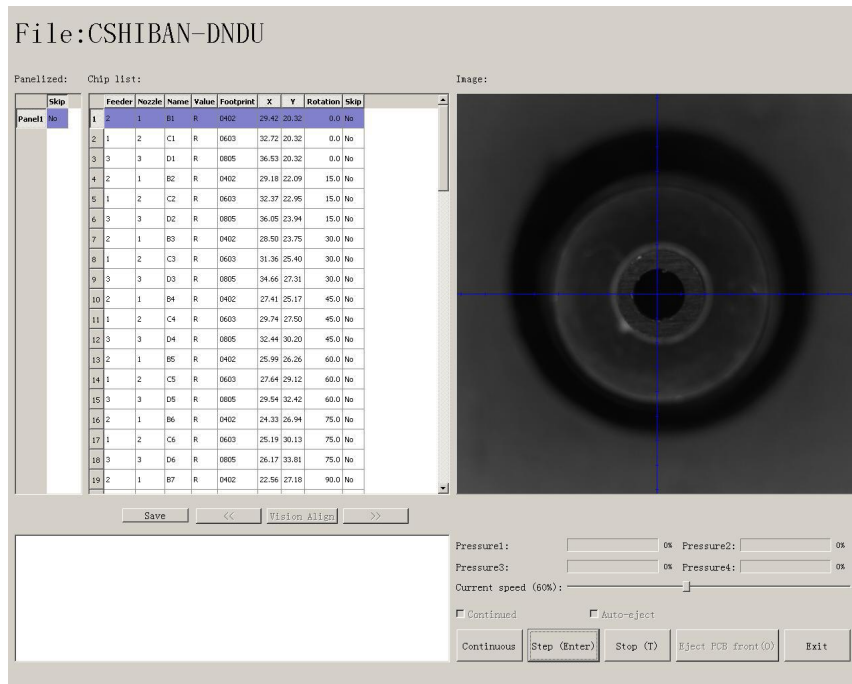

1.Method to mount one file:

First select one file, click"mount", then you will enter into one mounting page, above picture is an example of one file in mounting.

(1) On the top-left corner shows mounting process, chip list---by the variation of blue line, you can track process of mounting constantly.

(2) On the bottom-left corner shows some feedback during mounting process.

(3) One the top-right corner shows the status of picking and picking alignment

(4) On the bottom-right corner shows some control information

- Air pressure of 4 nozzles
- Placement speed, can be changed by manual during mounting
- Non-stop mount,this is used in one-stop smt production line, add conveyors in front and behind,
- Auto-eject PCB once finished, when select this option, after finished mounting task, PCB will eject its working area automatically
- Another control information,Continuous/Step/Pause/Eject PCB front-side manually/Stop
 Continuous, The machine will obey its order and work constantly
 Step, The machine will work one single step
 Pause, The machine will stop its work instantly
 Eject PCB front-side manually, In order to catch the PCB, after PCB assembly, click this option, PCB will eject from its feeding position. Kindly notice: After pause the machine then you can carry out this order.

Stop, before click this option, you need to click "pause" first

4.3. Manual Test

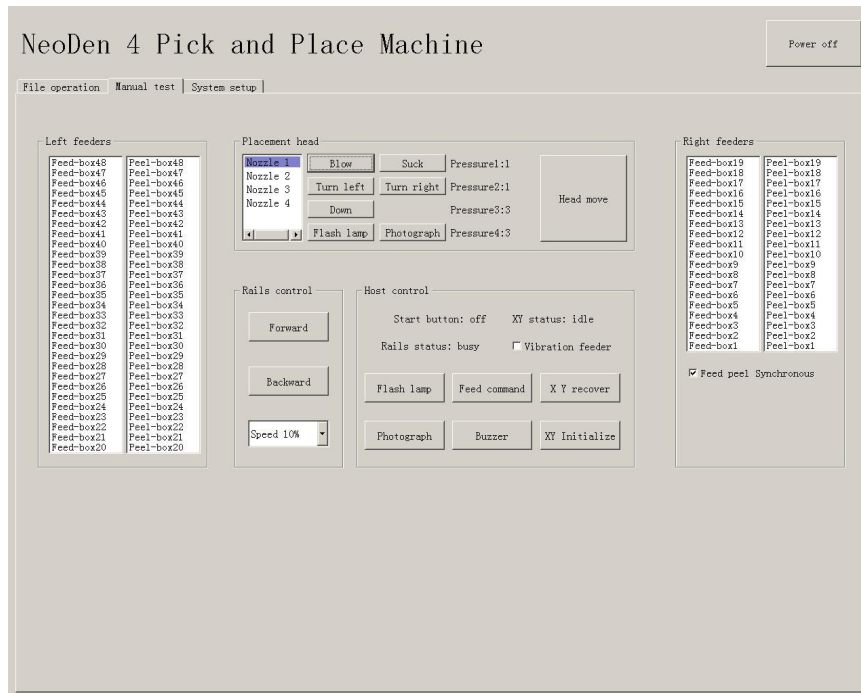

Function: Used for testing the basic functions, connection between software and hardware is the mainly function, details about testing as below:

4.3.1. Placement head

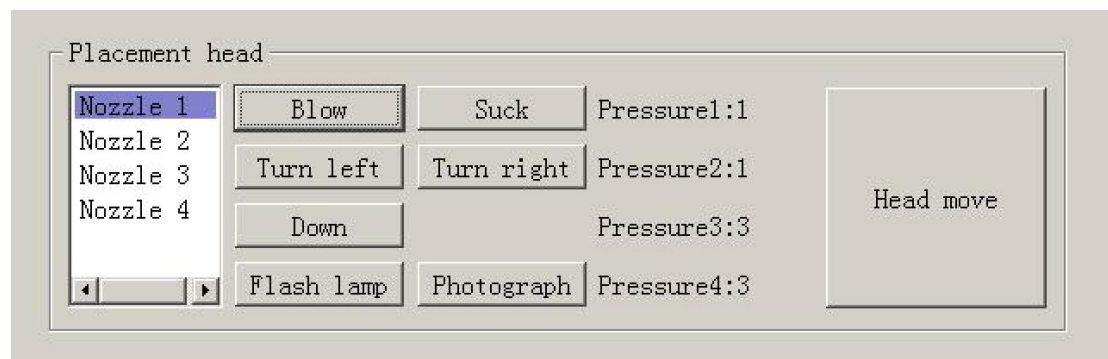

Choose nozzle 1, nozzle 2, nozzle 3, nozzle 4 to test separately

- Blow, after click this option, air will blow-off from selected nozzle
- Suck, after click this option, suction action will appear from selected nozzle
- Turn left& Turn right, selected nozzles will turn
- Down, after click this option, selected nozzle will descend slowly
- Down Looking Camera light, after click this option, Led light besides the camera will turn on
- Down Looking Camera Photograph, after click this option will take a picture
- Air pressure 1, 2, 3, 4, Based on the testing of nozzles, you can see pressure value of each nozzle.
- Head move, after click this option, you will enter into "head move" page, click to move

4.3.2. Rail control

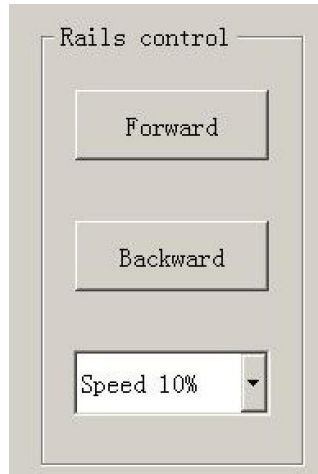

Function, test rail PCB feeding, forward PCB feeding, backward PCB feeding and feeding speed

4.3.3. Hose control

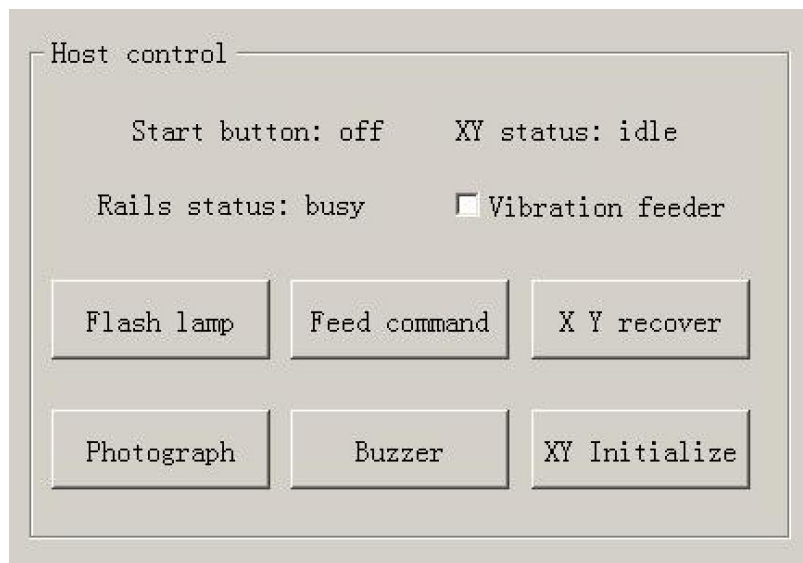

Function, test each function key

- Start button status, on the left side of machine, it has one start button, press this button the status will change
- Vibration feeder, after select this option, vibration tray will vibrate
- Up looking camera light, after click the light will turn on
- Up Looking Camera Photograph, after click this option will take a picture
- Send PCB feeding command, after click this option, PCB will feed forward
- Buzzer, after click this option some sound will appear

- X Y step out recover&X Y Initialize, after click this, machine will recover to its original position and coordinates in system will initialize.

4. 3. 4. Feeder test

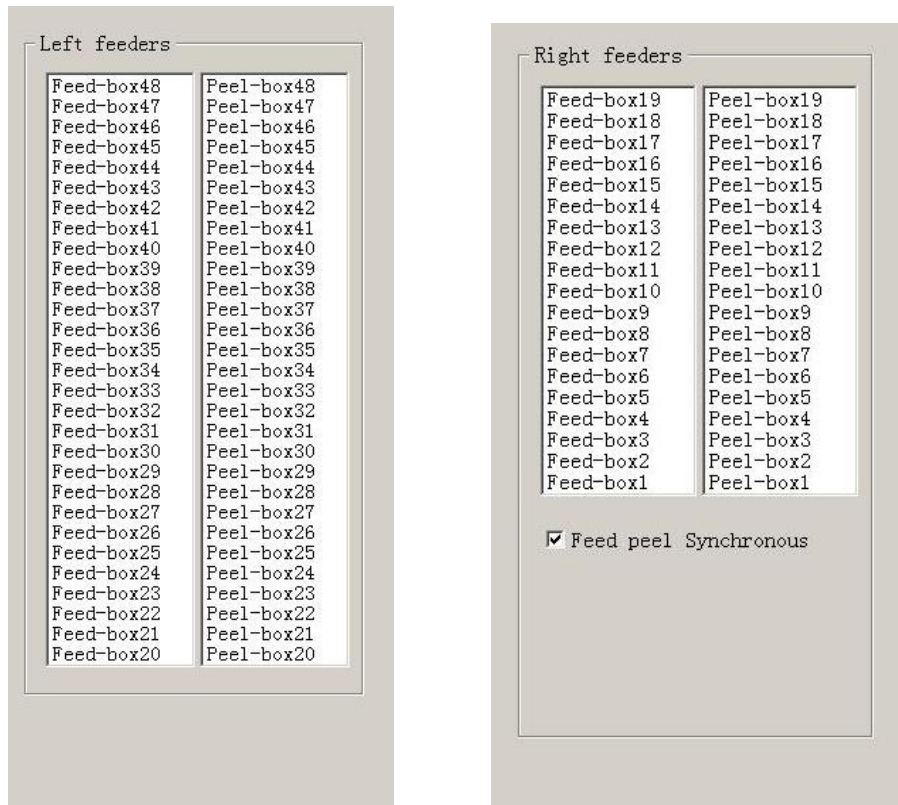

Function, test each feeder’s matching and feed box & peel box’s function. First, select” Feed-box and peel-box linkage”, then test function of feed box and peel box.

(1) click any feeder randomly, feed box and peel box will appear corresponding actions

4. 4. Factory settings

Function, this part arm at machine’ global parameter settings, any modified parameter will influence all mounting files, when modify this part please consider seriously. Especially the last page system settings, we suggest after using a period of time or under the guidance of our engineers then change its parameter.(Notice, before our machines leave factory, all parameter already be set and no need to change). This user manual just introduce all setting functions briefly, more details about parameter modification please refer to comments from our engineers.

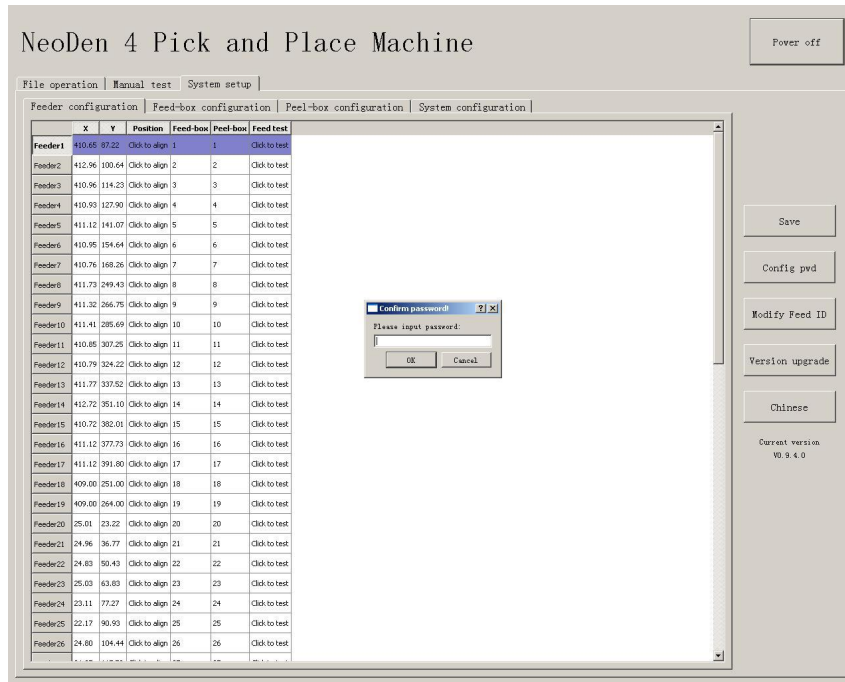

As pic show, function description of button on right side

- Save configuration: click it for saving after modify the parameters
- Modify password: click it, put into the password, then finish change the fourth page which is also the System interface.

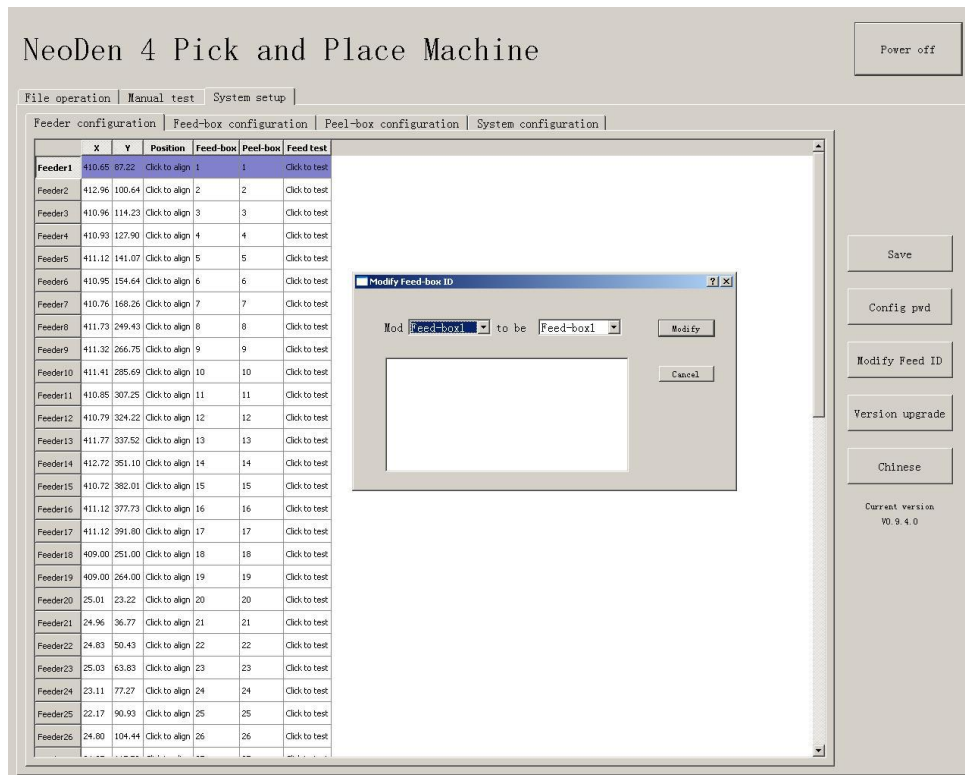

- Set up feeder ID: click and show as pic above. This is for modifying of feed-box ID. Feed-box is different from peel-box, feed-box ID is saved in feed-box itself . E.g.: Feeder of feed-box 1, it will be identified feed-box 1 no matter which port matched. So we will mark it. New feed-box default ID are all No.50, it need you to change them here by yourselves.

- Version upgrade: After receiving our new version file, you can upload it with clicking “version upgrade” to finish.
- ENGLISH: Change to the English version.

4. 4. 1. Feeder configuration

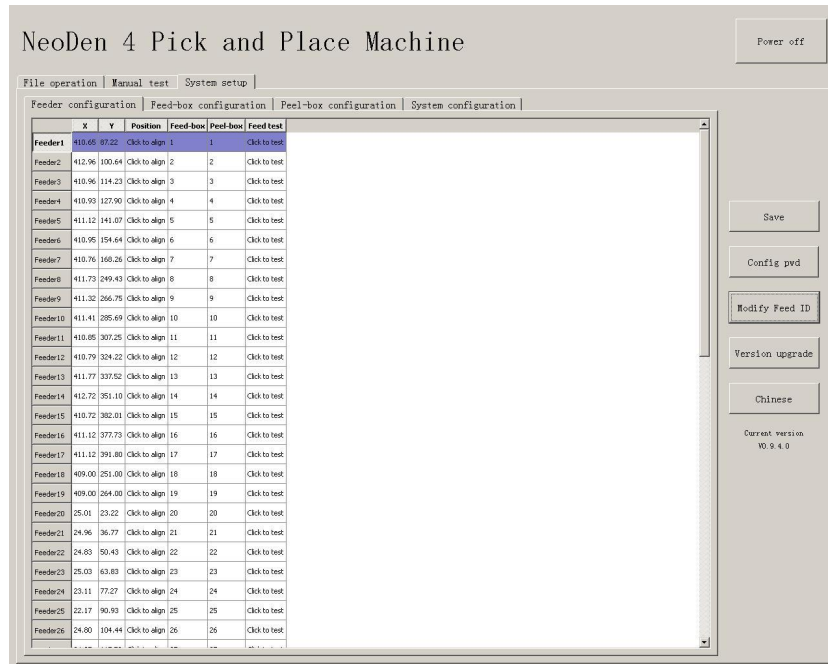

As figure show: parameters setting for all feeders.

First list on left side is feeder No.

X,Y parameters is setting the feeder’s pick position.

Click button of “click of align” in the list of “position”, then go into interface as below,

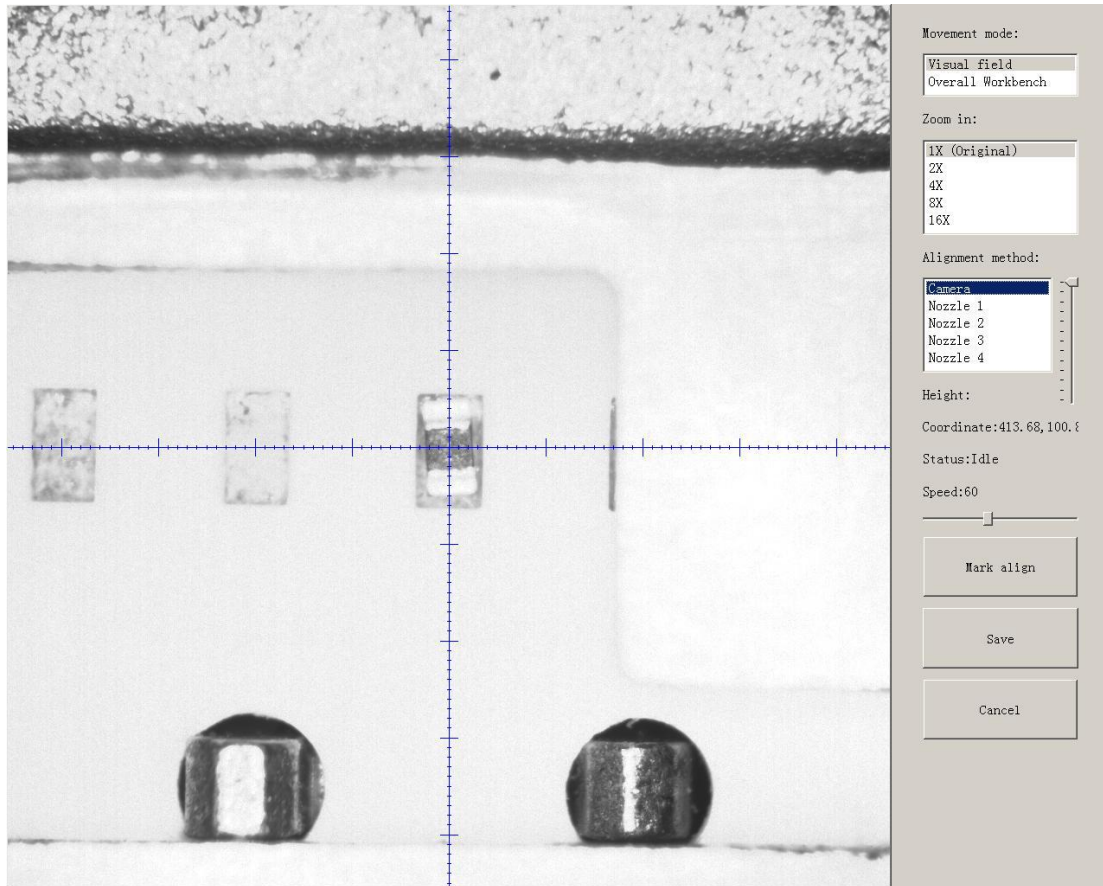

Save after setting well the pick position of the feeder. Same way as in the file.

1. “Feed-box” setting

It is used to set the feed-box ID. E.g., if you insert the feed-box 2 in the port 1, then it need to set the feed-box ID to be 2

2. “Peel Box”setting

“Peel box” is different from “Feed box”,the ID for peel box is corresponding to the port.For example,no matter which “Peel box” you connect,the ID always be No.1.

Above setting can help set the serial number of the stack in power supply port on the machine, See below fig.



For example, the default port ID for Stack 33 is 33, if the port 33 is broken and want to change to port 34, can set in this item

“Feed test”

Once clicked this item, then the machine will start Feed test, feed one component and help check whether the feed is normal

4. 4. 2. Feed setting

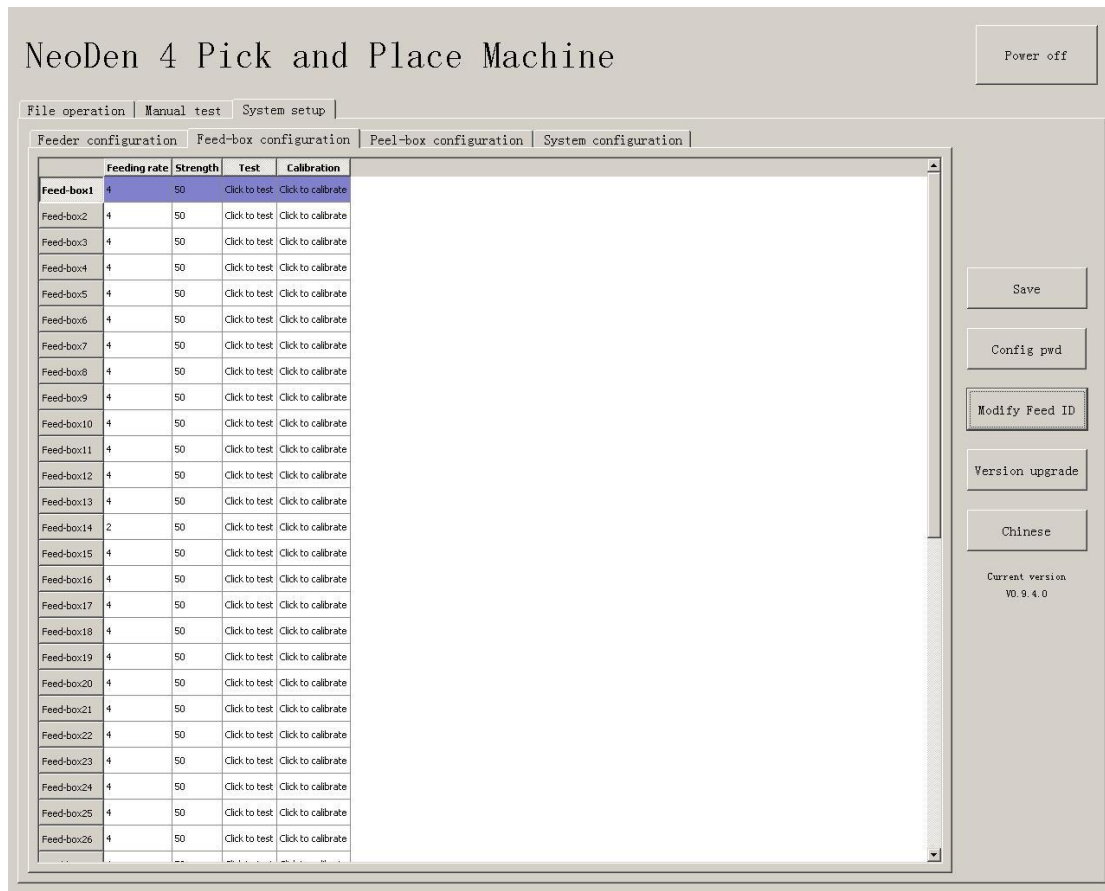

Function:Used to setting values for all stacks

Feed rate:The distance between two components,default value 4mm,for 0402,should set 2mm.

Strength Setting: Motor torque of feed for the stack(Normally no need to change).

Test:The machine will do feed test separate after clicking this item,peel box won't work during above test

Alignment:Click peel box,the motor idling several rings to do the initial position of the calibration.

Used if there are problems during peel operation,then can click this item to repair. Normally no need to click.

4. 4. 3. Peel Configuration

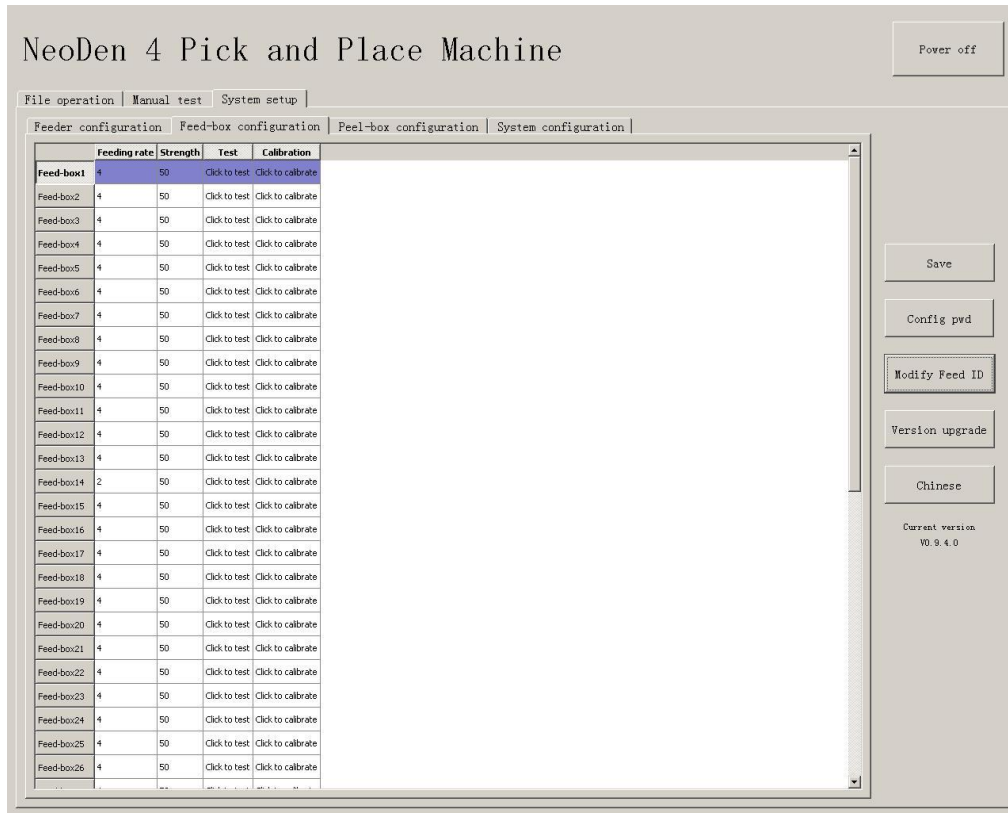

Function: Peel configuration as above figure show, used to set the values for all peel boxes

Feed rate: Similar meaning in Feed box part, mean length of rotation each time

Strength: Torque setting of Peel motor (Plastic tape will be difficult strip away in the case of being affected with damp, can adjust bigger values of motor torque here)

Test: The machine will do peel test separate after clicking this item, feed box won't work during above test

4. 4. 4. System setting

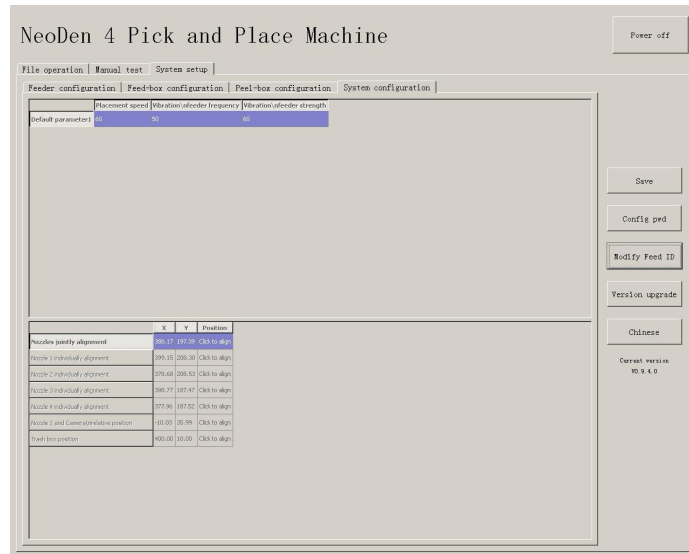

Function: it is mainly for correction the position of suction nozzle.(Notice: In case change by mistake,we 've locked it by password. It can be changed by clicking the button of Password change and then insert password. Strongly recommend operating it under our engineer's guidance).

1. Default parameters 1 setting

- Default speed: placement head movement speed under overall situation, priority is not as fast as speed set in stacks.
- Vibration feeder frequency: setting the frequency of vibration feeder. Discharge state will be more stable if frequency high.
- Vibration feeder strength: it depends on the component, if component too small and strength set high it will shake out the component easily, of course if strength small, the discharging speed will be slower.

2. Nozzle Jointly Alignment setting

Click test button and go into interface below:

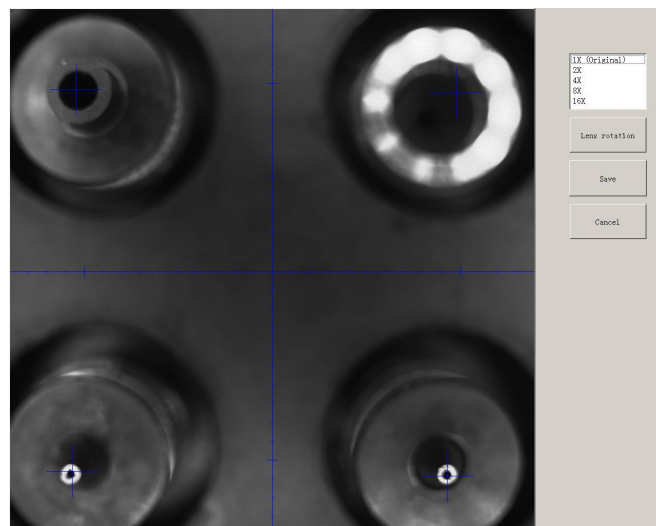

- Click the central point among four nozzles under the shot can set the central point.
- Another way is press CTRL button then click the mouse to make each nozzle to identify their own central point in the four quadrants.

(Notice: Please click the LENS ROTATION before setting the suction nozzle, then PnP machine will collect nozzle's 360 degree rotation photos to synthesize. After that, press CTRL button to set each nozzle's identification of central point.

- Save it after finishing the setting.
- 3. Correct nozzle 1~nozzle 4 separately**
 - 4. Click test and go into interface below**

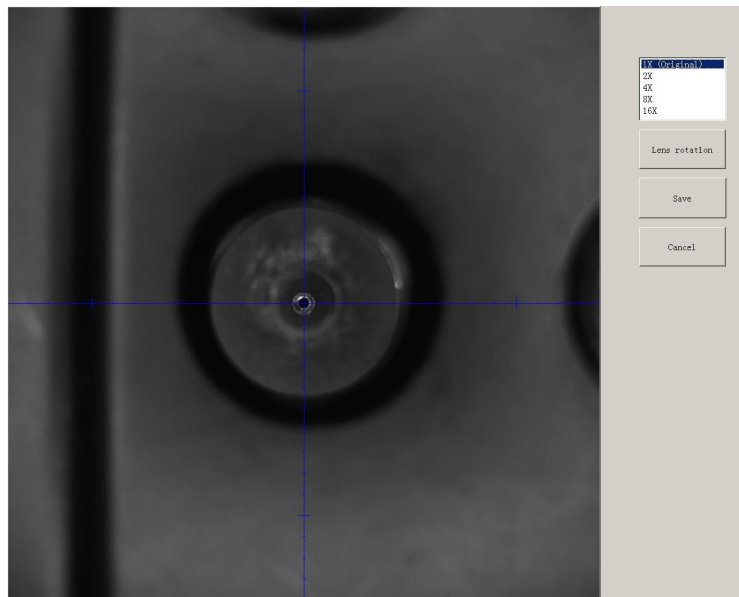

Operation steps: 1.click the button of LENS ROTATION to let machine take photos of nozzle's 360 degree rotation . 2.click the central point of nozzle 3. Click the save button.

- Relative position of nozzle 1 and camera: it is for the synchronism of nozzle and camera, setting it when placement position do not matched with the camera position.Click setting then go into interface below:

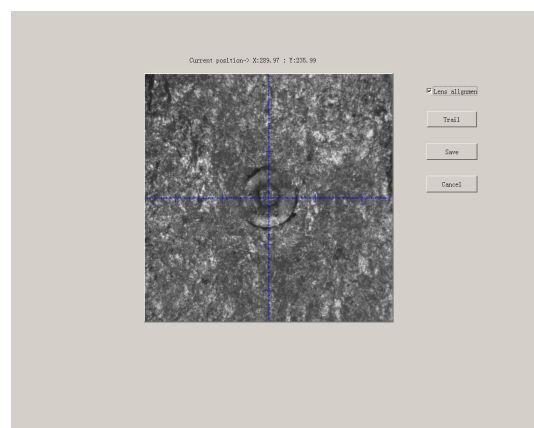
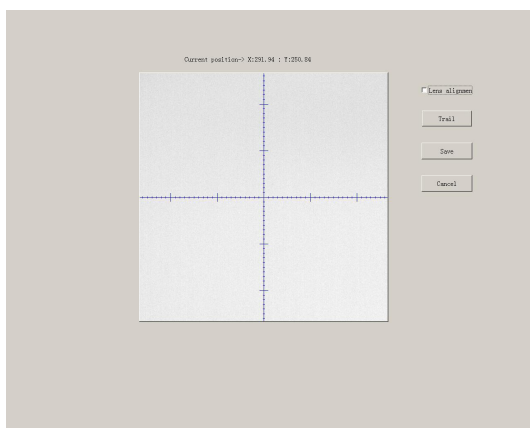

- Move the nozzle to any place of PCB board, put one piece of carbon paper, then click REMAINS(MARK), placement head will rotate and leave a dot, after that click the button of

Focus that dot and save, it will be done (show as photo above).

- Trash box position: setting the position of dropping component, it depends.

4. 5. First trial and testing

1. First dry run

Usually we would suggest you to have a dry run (no components are loaded) before production test. After it goes smoothly, you can start to produce few boards.

2. Production test

- ① Make a programming file
- ② Test the file to pick and place components.

3. Inspection

- ① Inspection Items

Check if the specification, direction, polarity of components are aligned with what they should be.

- Whether the components are damaged or the pins are distorted.
- Whether the component is off beyond allowance.

- ② Inspection Methods

The inspection methods vary from the equipment that you have.

Except visual inspection, all of amplifier, microscope, online or offline AOI equipment can be applied if the pitch of IC is quite small to check.

- ③ Inspection Standard

Please follow SOP to do inspection or any other general standards (IPC Standard and SJ / T10670-1995 SMT General Technical Requirements)

Adjust the programming file according to the placement effect after the first production test

If there is any issue of specification, direction and polarity, please follow process file to amend.

- If the components are off, please adjust the file by following two methods
 - a. If the placement effects of all components are off in the same direction, it would be the fiducial issues. Please resolve this issue by adjusting the coordinate of fiducials according to its value of deviation.
 - b. If there are several components off beyond allowance, you'd better adjust their coordinates on working file with down-looking camera.
- If there are couple of issues occur during test, some other points need to be considered.
 - a. Frequent pickup failure. Some suggestions are listed below,
 - The pick height is inappropriate, please revise the value after an inspection or a pick-test;
 - The pick offset needs an adjustment, it should be aligned with the center of component reel slot rather than that of component.
 - Due to peel strength or installation issue of wasted film, the film on tape won't be peeled completely
 - The nozzle was blocked
 - The nozzle is damaged or has a crack
 - The size issue of nozzle would cause air leakage or insufficient suction.
 - The air hose is blocked or has a leakage problem, and even the pump has an issue.
 - b. Frequently throwing components. Some suggestions are listed below,
 - Up-looking camera can't take a clear picture of component due to brightness issue for

example.

- The size or shape isn't aligned with that in "Footprint library"
- The size of nozzle is inappropriate or insufficient suction.
- The nozzle is damaged or blocked, and even has a crack

4. 6. Continuous SMT production

Follow the SOP to start production

Notes

1. Do not touch the surface to board to avoid damaging the printed solder paste.
2. When the error message occurs, please checkout and solve it a.s.a.p.
3. Once reloading the component during production, pay attention to the model,specification, polarity and direction of components.

5. Structure and maintenance instruction

5. 1. Structure chart

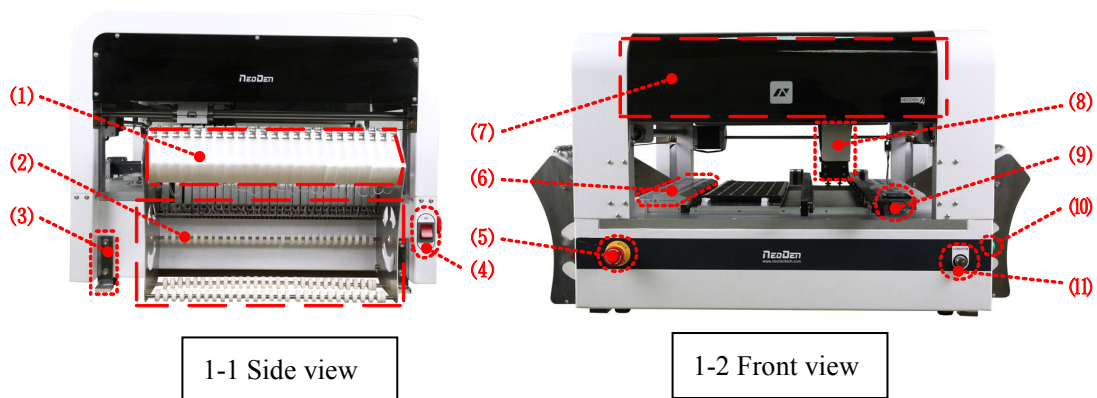

- | | | |
|-------------------|----------------------|----------------------|
| (1) Peel-box | (2) Tape&Reel holder | (3) fixed support |
| (4) Power switch | (5) Emergency stop | (6) Feed-box |
| (7) Cover | (8) Placement head | (9) Vibration feeder |
| (10) Pause button | (11) Conveyor port | |

5.1.1. Peel-box

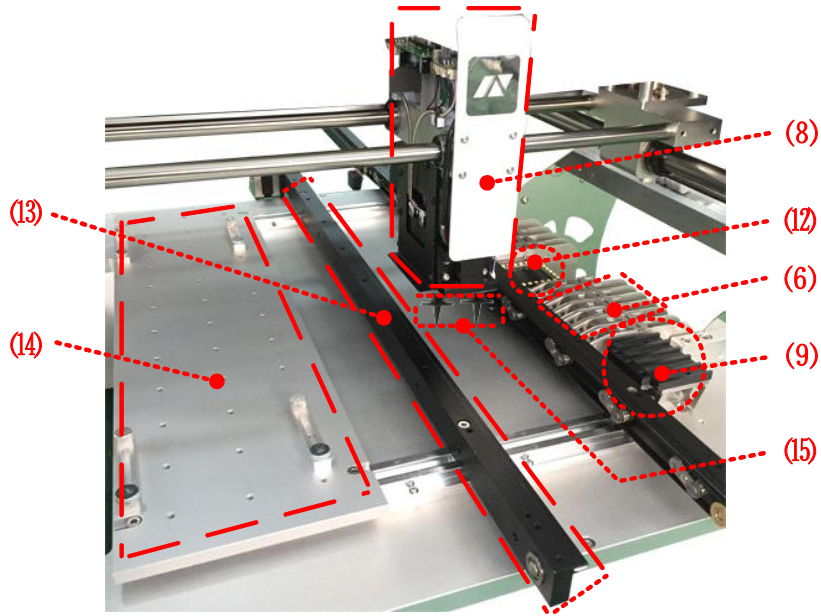

- Fix the peel-box

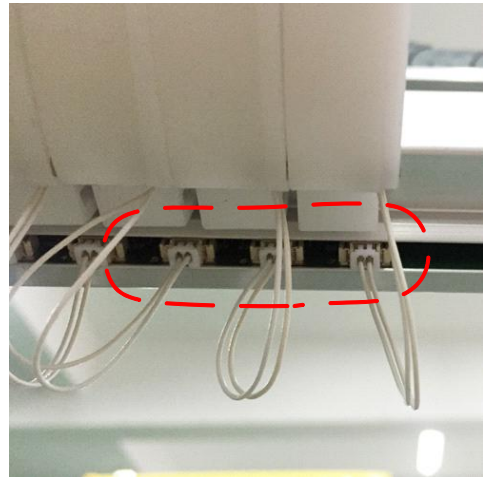
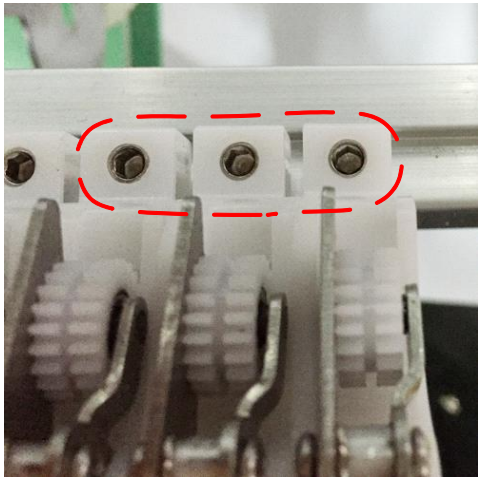

- Installation of peel-box

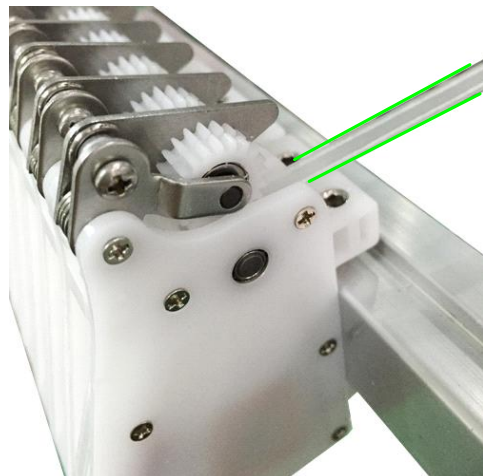
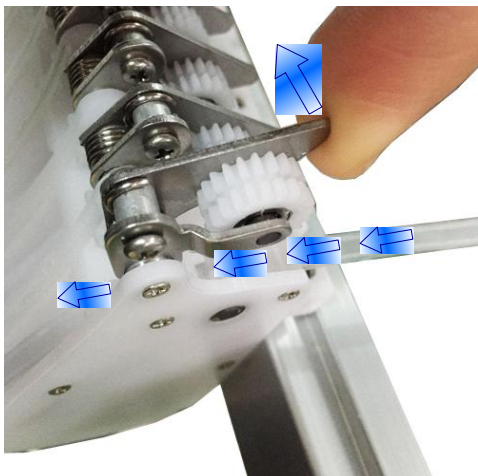

5. 1. 2. Tape&Reel holder

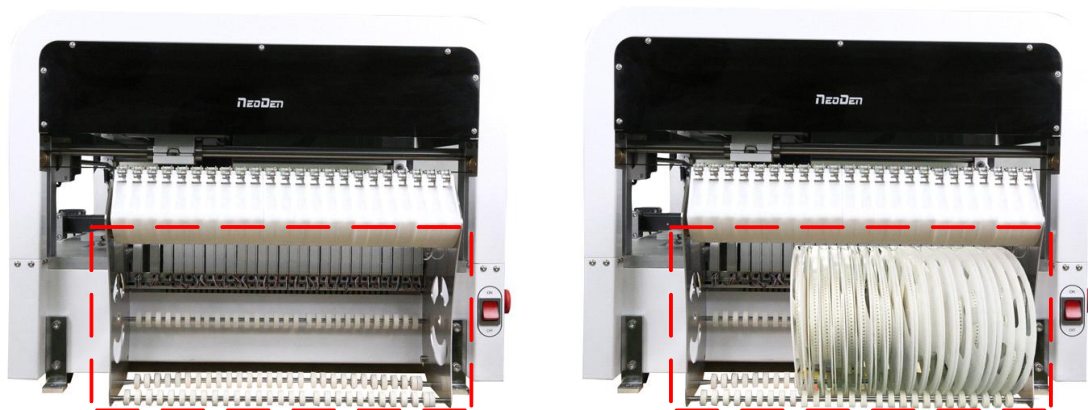

5. 1. 3. Fixation support



5. 1. 4. Feed-box

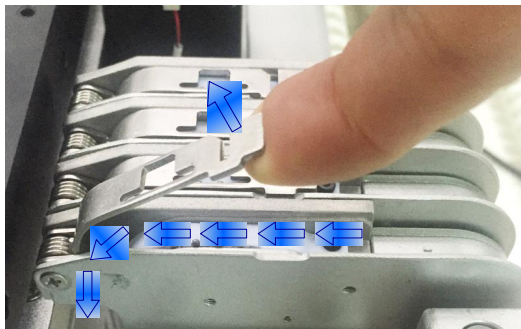
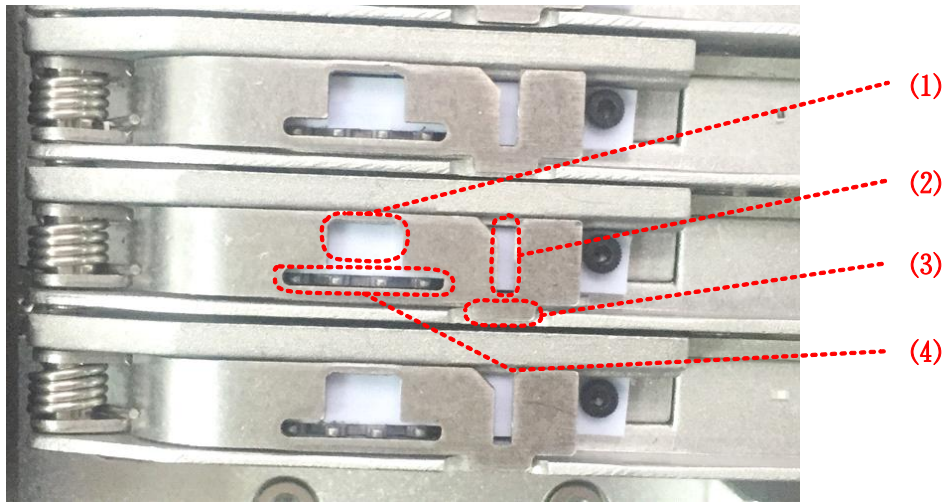

5. 1. 5. Vibration feeder

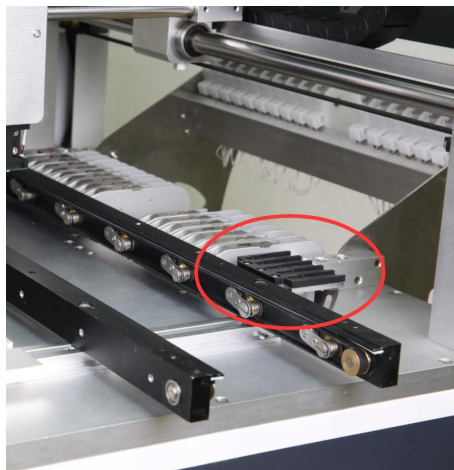

5. 1. 6. Auto-rails

- Adjustment of auto-rails

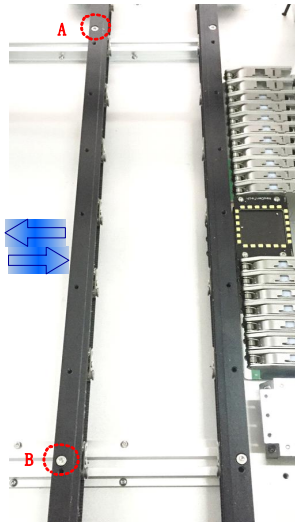

Fig.1

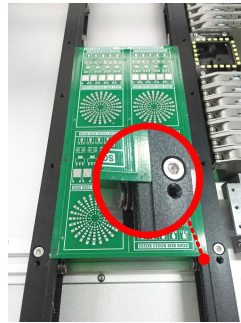

Fig.2

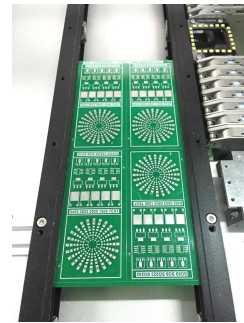

Fig.3

See(Fig.1):Loosen screws on A and B, then the left rail can be moved arbitrarily.

See(Fig.2):Put PCB on the groove of rails and tighten and screws A and B once confirmed the width.



See(Fig.3):Once finished width adjustment, put the board into rails. Check the effect picture as below

5. 1. 7. Nozzle

- The size of nozzle

Please choose nozzles according to the shape and size of components.

Table 1-1 Nozzle

Model	XN03	XN07	XN14	XN22	XN40	XN75
Illustration						
Inner diameter	0.3mm	0.7mm	1.4mm	2.2mm	4mm	7.5mm

- Reference of nozzle selection

In order to assure placement accuracy, please select nozzles according to the shape and size of components.

Table 1-2 Size comparison of nozzles

Size	Minimum diameter	Recommendation
XN03	0.2mm	0201,0402
XN07	0.5mm	0402,0603,0805,diode
XN14	1.2mm	1206,1210,1812,2010,SOT23,5050
XN22	2.0mm	SOP series ICs,SOT89,SOT223,SOT252
XN40	4.0mm	ICs from 5 to 12mm
XN75	7.5mm	ICs bigger than 12mm

	size		size
0201	0.6*0.3	0402	1.0*0.5
0603	1.6*0.8	0805	2.0*1.2
1206	3.2*1.6	1210	3.2*2.5
1812	4.5*3.2	2010	5.0*2.5
SMA	4.0*2.5	SMB	4.0*3.3
SMC	6.6*5.6	SOT23	3*1.4
SOT89	4.5*2.5	SOT223	6.4*3.7
TO252	6.5*6.3		

5. 2. Maintenance

5. 2. 1. Take effective measures to reduce/avoid malfunction

- **reinforce daily maintenance**

P&P machine is that high-accuracy device which requires a clean working environment with constant temperature and humidity, so it's necessary to have a routine maintenance.

1. Requirements for operator

③ Operator should get a basic operator training, which should cover fully all the skills and knowledge needed to safely operate the type of pick and place machine.

④ Operating strictly against equipment's instruction. DON'T use machine with problems. Stop the machine once malfunction appears and contact with the after-sales service staff, restart to work after problem solved.

2. Operator should be concentrated

Observation — to see whether there is abnormal situation, such as peel-box doesn't work, plastic tape is broken etc.

Listening — whether have strange sound, such as noise from placement head, sound of loss component, strange noise of conveyor etc.

Handwork — solve some small problems in time, such as install feeder, correction placement position etc. If the main machine body or circuit problem, please consult after-sales staff.

3. Formulate measures to reduce/ avoid big problem

The most easily appeared problem during work are placement wrong components and placement misaligned. Supply below measures for ref.

① It need to check whether the components' package is matched with related feeder. If not, please correct them.

② As to tape reel feeder, when ran out of one reel, operator must check whether newly changed tape reel is correct or not.

③ After import the SMD file or edit chip list manually, please recheck each component's No., nozzle rotation angle and placement position to make sure correct.

④ Operator must check the first finished PCB of each file. If any problem, please find solutions such as revise program to solve it.

⑤ To check the placement position misaligned or not, component loss problem in regular work. Find reason in time and solve it.

⑥ In sum, P&P machine's running speed and placement accuracy still has limit. People's work is important to run machine on its proper role. So it's necessary to comply with effective measures to keep machine normal work, its placement quality and efficiency.

5. 2. 2. Maintenance of device

● Check below points daily

1. Please check below before turn on the machine

① Temperature and humidity: temperature range 20°C ~ 26°C, humidity range 45 ~ 70%.

② Working environment: please keep air fresh to avoid corrosive air in.

③ Make sure there's no obstacle on dual rails or the whole working area.

④ Make sure camera lens is clean, no dirty things.

⑤ Make sure no obstacles around the head nozzles.

⑥ Please check whether nozzle is dirty or out of shape and adopt relevant cleaning measure or change new nozzle.

⑦ Please check whether feeders are well installed, and keep feeders clean.

⑧ Please check whether the air hose is well connected with machine.

1. Please check listed below after turn on the machine.

Error tips will show on the monitor if the machine work abnormality.

① Check the monitor screen whether display normally after system starting working. Check emergency switch whether could work normal.

② Check the placement head whether could return to the original place.

③ Whether have abnormal noise when placement head move.

- ④ Check negative pressure whether in normal range or not.
- ⑤ By the way checking PCB's transmission on dual rails to know whether sensor is still work fine.

- **Check below points monthly**

1. X,Y axis--please make sure no abnormal noise when placement head move.
2. X,Y motor--please make sure motors working well, no abnormal heating appearance.
3. Nozzle--please check nozzle whether up down flexibly, not bent, check the suck surface whether level.
4. Air hose--check the air hose and connector, make sure hose is fine without broken, abrasion or air-leak etc.
5. Negative pressure--check all nozzles' negative pressure.If abnormal,please clean nozzles.
6. Positive pressure--check whether they're normal.
7. Optical axis--please check whether it is covered dust. Please keep it clean and lubricated.
8. Operation button--check each button to make sure they are well-worked
9. Connector--check if well-connected of the air connector and air hose.

5. 2. 3. Placement failure analysis and trouble shooting

- **Placement failure analysis**

Whether Pick and Place machine can run normally or not, which will directly impact on production quality and volume. To make the machine run properly, we must fully understand the structure and characteristics of the machine, master every kinds of failure patterns of manifestation,reason and troubleshooting methods. Finding problems and reasons in time and timely troubleshooting can help ensure efficiency of the machine during working.

(1) Common failures

- not start boot failure
- head doesn't move
- fail to feed forward a board
- Pick failure
- Place failure

(2) Main reasons of failure

- transmission systems-driven PCB and head movement transmission system and the corresponding sensors.
- Air Route-Air pipe,nozzle
- Nozzle size not suit to the component
- No info in Footprint library
- Irregular component
- Incorrect values setting of component's height or pick height

(3) placement troubleshooting

failure patterns of manifestation, Reasons, troubleshooting methods

- head doesn't move

Solutions:

1. Sensor is poor connected or short-circuited. Please wipe off the dust or lubrication on sensor or even exchange a sensor
2. Longitudinal sensor or sensor poor connect or short circuit, check and repair the transmitter or add too much lubricating oil on sensor-clean the sensor

- Rails fail to advance the board feed forward after uploading the PCB

Solutions:

1. The rails belt get loose or broken, need to be adjusted or exchanged.
2. The rails drive motor doesn't work:

- Nozzle can't pick up component
- Pick up position offset
- Components fall down during moving

Solutions:

1. Nozzle had been wearing or become aging, the crack causes leakage.- replace with a new nozzle
2. The nozzle's bottom surface is uneven or get stuck by solder paste or other dirt Please wipe it off and use cleaning needle to clean the nozzle
3. Current nozzle size is not suit to component , change another one
4. Surface uneven on the component, replace with a qualified one
5. Component is sticking to the bottom tape;
6. Burrs on tape hole stuck component;
7. Component's pin get stuck in the corner of the den;
8. Gap between components and tape package hole is not big enough , uncover the plastic tape and upside down to check if the components can fall down or not.
9. Plastic adhesive tape is too sticky or flimsy and then can not be unfolded. Or plastic adhesive tape has been tore down from edge side.
10. Pick up position offset. Actual Feed box is offset from Feeding center, check X, Y, Z data and do reprogram.

- Placement offset

Solutions:

1. Programming issue(some components' positions are inaccurate), amend the coordinates; If all components are offset, please modify fiducials.
2. The components' thickness setting errors, modify components information on Footprint Library
3. Pick height is too high that causes components being dropped. Please reset the Pick Height value
4. Pick height is too low that causes slide problem during placement
5. High speed issue. Lower the speed to achieve a more accurate rotation and placement effect.

5. 2. 4. Related issues during Solder paste printing process

● Stencil Printing Technology

Screen printing technology refer to using ready-made stencil, directly contact to the printer in a certain way, make the solder paste evenly flow on the stencil and then leak into the mesh through the holes. When getting the stencil away, solder paste had been covered to the printed circuit board solder graphics

corresponding, thus complete the solder paste printing on the PCB.

● Inspecting of solder paste printing

Printing process is one of the key working procedure to ensure the quality of surface mounting. According to the statistics,under the premise of guaranteed quality about components and PCB,correctly PCB design, 70% of the surface quality problem caused during printing process. In order to ensure the quality of SMT assembly, it is necessary to strictly control the quality of the solder paste printing.

The amount of solder paste printing requirements are as follows:

- 1.The using amount of solder paste should be uniform, good consistency. Solder paste graphics should be clear, try to avoid adhesion between adjacent graphics. Solder paste graphics and solder graphics should be consistent.
- 2.In general,keep unit area amount of solder paste about 0.8 mg/mm². For fine pitch components, should be 0.5 mg/mm² (using stencil thickness and hole size to control in the actual operation).
- 3.Printed on the substrate of solder paste compared with required value, a certain deviation is permissible, the covering area of the solder paste on each solder pad should be more than 75%.
- 4.Should be no seriously collapsing problem and edges neatly after solder paste had been printed, the dislocation shouldn't be larger than 0.2 mm, for solder pad of fine pitch components,dislocation shouldn't be larger than 0.1MM,pollution by solder paste is not permitted to the PCB.

● The defects of solder paste printing, reasons and solutions

Excellent printing graphics should be uniform in both vertical and horizontal direction,full,clean all round, solder paste fill solder pad. Using above such printing graphics device, after reflow soldering,will get good welding effect then.

Solder paste graphics dislocation

Reasons: Holes on the stencil not good match with solder pad; No enough precision of the Printing machine

Issues: easily cause bridge connection

Solutions:Adjust the stencil position; Adjust the printing machine.

Solder paste graphics have icicles and dents

Reasons:Scraper's pressure is too large; Rubber scraper's hardness is not enough; Holes are too

big in the stencil

Issues: Solder paste's required volume is not enough, easy to appear faulty soldering; solder joint strength is not enough.

Solutions: Adjust the printing pressure; Use metal scraper; Improved holes designing in the stencil.

Too much solder paste

Reasons: Holes are too big in the stencil; The gap is too big between stencil and PCB.

Issues: easily cause bridge connection

Solutions: Check the holes size in stencil; Adjust the parameters of printing, especially the gap between PCB and stencil

Graphic uneven (have breakpoints)

Reasons: Holes' wall are not smoothness enough; not wipe residual solder paste in using for many times; Solder paste's thixotropy is bad.

Issues: Easy cause no enough solder paste, lead to the problem such as faulty soldering.

Solutions: Wipe the stencil

Contamination of the graphics

Reasons: Not wipe residual solder paste in stencil after using for many times;; Poor quality of solder paste; Shake problem when getting the stencil way

Issues: easily cause bridge connection

Solutions: Wipe and clean stencil; replace solder paste; adjust the machine.