



**WINSTAR Display Co.,Ltd.**  
**華凌光電股份有限公司**



**Winstar Display Co., LTD**

**華凌光電股份有限公司**

WEB: <https://www.winstar.com.tw> E-mail: sales@winstar.com.tw



## SPECIFICATION

**CUSTOMER :** \_\_\_\_\_

**MODULE NO.:** WF101FSYFPLHTX#

<p><b>APPROVED BY:</b> ( FOR CUSTOMER USE ONLY )</p>	<p><b>PCB VERSION:</b> _____ <b>DATA:</b> _____</p>
--	---

SALES BY	APPROVED BY	CHECKED BY	PREPARED BY
			葉虹蘭
<b>ISSUED DATE: 2019/01/22</b>			

**RECORDS OF REVISION**

DOC. FIRST ISSUE

VERSION	DATE	REVISED PAGE NO.	SUMMARY
0	2017/12/19		First issue
A	2018/05/30		Modify PCB & Electrical Characteristics
B	2018/06/12		Change the characteristics of adapter in note 2
C	2018/07/11		Add LED life time
D	2018/08/29		Add Uniformity
E	2019/01/22		Modify Contour Drawing & Touch Panel Information

# Contents

- 1.Module Classification Information
- 2.Summary
- 3.General Specification
- 4.Absolute Maximum Ratings
- 5.Electrical Characteristics
- 6.Interface Timing Characteristics
- 7.Optical Characteristics
- 8.Interface
- 9.Reliability
- 10.Touch Panel Information
- 11.Contour Drawing
- 12.Other

# 1. Module Classification Information

W F 101 F S Y F P L H T X #  
 ① ② ③ ④ ⑤ ⑥ ⑦ ⑧ ⑨ ⑩ ⑪ ⑫ ⑬

①	Brand : WINSTAR DISPLAY CORPORATION											
②	Display Type : F→TFT Type, J→Custom TFT											
③	Display Size : 10.1” TFT											
④	Model serials no.											
⑤	Backlight Type :		F→CCFL, White S→LED, High Light White				T→LED, White Z→Nichia LED, White					
⑥	LCD Polarize Type/ Temperature range/ Gray Scale Inversion Direction		A→Transmissive, N.T, IPS TFT C→Transmissive, N. T, 6:00 ; F→Transmissive, N.T,12:00 ; I→Transmissive, W. T, 6:00 K→Transflective, W.T,12:00 L→Transmissive, W.T,12:00 N→Transmissive, Super W.T, 6:00				Q→Transmissive, Super W.T, 12:00 R→Transmissive, Super W.T, O-TFT V→Transmissive, Super W.T, VA TFT W→Transmissive, Super W.T, IPS TFT X→Transmissive, W.T, VA TFT Y→Transmissive, W.T, IPS TFT Z→Transmissive, W.T, O-TFT					
⑦	A : TFT LCD B : TFT+SCREW HOLES+CONTROL BOARD C : TFT+ SCREW HOLES +A/D BOARD D : TFT+ SCREW HOLES +A/D BOARD+CONTROL BOARD E : TFT+ SCREW HOLES +POWER BOARD					F : TFT+CONTROL BOARD G : TFT+ SCREW HOLES H : TFT+D/V BOARD I : TFT+ SCREW HOLES +D/V BOARD J : TFT+POWER BD						
⑧	Resolution:											
	A	128160	B	320234	C	320240	D	480234	E	480272	F	640480
	G	800480	H	1024600	I	320480	J	240320	K	800600	L	240400
	M	1024768	N	128128	P	1280800	Q	480800	R	640320	S	480128
	T	800320	U	8001280	V	176220	W	1280398	X	1024250	Y	1920720
	Z	800200	2	1024324	3	7201280	4	19201200	5	1366768	6	1280320
⑨	D: Digital L : LVDS M:MIPI											
⑩	Interface:											
	N	Without control board			A	8Bit		B	16Bit		H	HDMI
	I	I2C Interface			R	RS232		S	SPI Interface		U	USB
⑪	TS:											
	N	Without TS			T	Resistive touch panel			C	Capacitive touch panel (G-F-F)		
	G	Capacitive touch panel (G-G)					C1	Capacitive touch panel (G-F-F)+OCA				
	C2	Capacitive touch panel (G-F-F)+OCR					G1	Capacitive touch panel (G-G)+OCA				
	G2	Capacitive touch panel (G-G)+OCR					B	CTP+GG+USB				
⑫	Version: X:Raspberry pi											
⑬	Special Code		#:Fit in with ROHS directive regulations									

## **2.Summary**

TFT 10.1” is a IPS transmissive type color active matrix TFT liquid crystal display . In-Plane Switching (IPS) was one of the first refinements to produce significant gains in the light-transmissive characteristics of TFT panels. It is a technology that addresses the two main issues of a standard twisted nematic (TN) TFT display: colour and viewing angle.

### **3. General Specifications**

<b>Item</b>	<b>Dimension</b>	<b>Unit</b>
Screen Diagonal	10.1	inch
Number of Pixels	1280 x 3(RGB) x 800	dots
Module dimension	230.56 x 155.01 x 28.4	mm
Active area	216.96 (H) x 135.6(V)	mm
Pixel pitch	0.1695 x 0.1695	mm
Display Mode	Normally Black	
Pixel Arrangement	R.G.B. Vertical Stripe	
Backlight Type	LED, Normally White	
Aspect Ratio	16:9	
Electrical Interface (Logic)	HDMI	
With /Without TP	With RTP	
Surface	Anti-Glare	

\*Color tone slight changed by temperature and driving voltage.

## **4. Absolute Maximum Ratings**

<b>Item</b>	<b>Symbol</b>	<b>Min</b>	<b>Typ</b>	<b>Max</b>	<b>Unit</b>
Operating Temperature	TOP	-20	—	+70	°C
Storage Temperature	TST	-20	—	+70	°C

Note: Device is subject to be damaged permanently if stresses beyond those absolute maximum ratings listed above

1. Temp.  $\leq 60^{\circ}\text{C}$ , 90% RH MAX. Temp.  $> 60^{\circ}\text{C}$ , Absolute humidity shall be less than 90% RH at  $60^{\circ}\text{C}$



# 5. Electrical Characteristics

## 5.1. Operating conditions:

Item	Symbol	Condition	Min	Typ	Max	Unit	Remark
Supply Voltage For LCM	VDD	—	4.9	5	5.1	V	—
Supply Current For LCM	IDD	—	—	1.9	2.7	A	Note 1
LED life time	—	—	50000	—	—	Hr	Note 4

Note 1 : This value is test for VDD =5.0V , Ta=25°C only

Note 2 : Display with Raspberry pi the driver power is over USB , first make sure you have a 3A power supply, with a good quality USB cable, a thin wire power cable is no good. Make sure its 24AWG or smaller, shorter USB cables are better too.

Note3 : Touch Panel driver is base on the mouse driver program and through USB port connect to PC or embedded board.Can only support the single touch.

Note 4: The “LED life time” is defined as the module brightness decrease to 50% original brightness at Ta=25°C and IL =480mA. The LED lifetime could be decreased if operating IL is lager than 480mA.

# 6.LVDS Signal Timing Characteristics

## 6.1. AC Electrical Characteristics

Parameter	Symbol	Values			Unit	Remark
		Min.	Typ.	MAX.		
LVDS Differential input high Threshold voltage	RxVTH	-	-	+100	mV	RXVCM=1.2 V
LVDS Differential input low Threshold voltage	RxVTL	-100	-	-	mV	
LVDS Differential input common mode voltage	RxVCM	0.7	-	1.6	V	
LVDS Differential voltage	VID	200	-	600	mV	

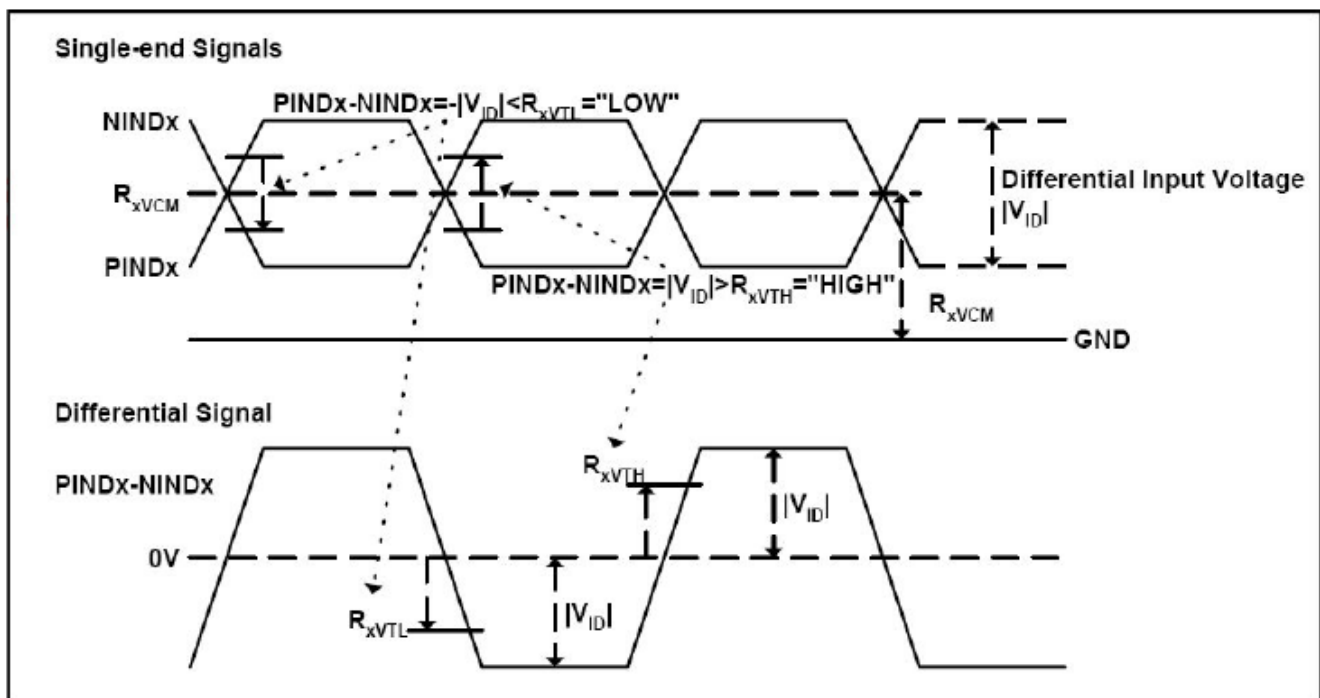

## 6.2. Timing Table

Parameter	Symbol	Value			Unit	Remark
		Min.	Typ.	Max.		
Clock Frequency	1/Tc	68.9	71.1	73.4	Mhz	Frame rate =60Hz
Horizontal display area	thd	1280			Tc	
HS period time	th	1410	1440	1470	Tc	
HS Width +Back Porch +Front Porch	tHW+ tHBP +tHFP	60	160	190	Tc	
Vertical display area	tvd	800			tH	
VS period time	tv	815	823	833	tH	
VS Width +Back Porch +Front Porch	tvW+ tvBP +tvFP	15	23	33	tH	

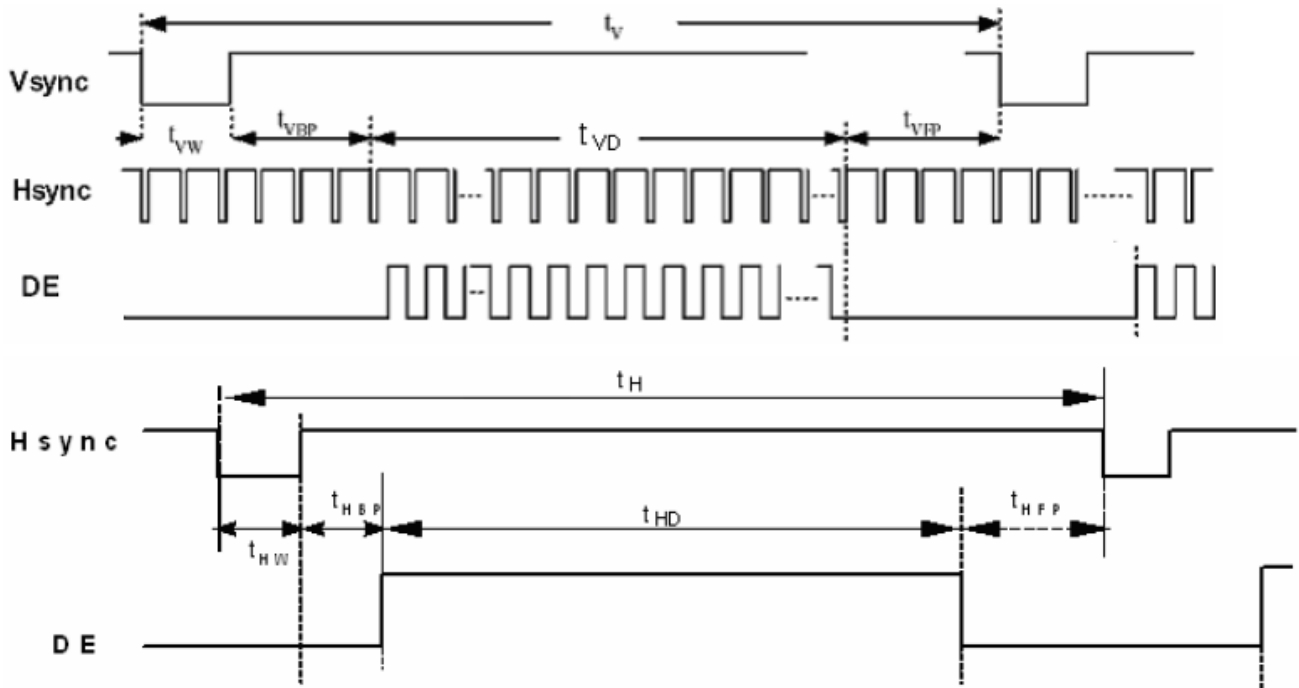

### 6.3. LVDS Data Input Format

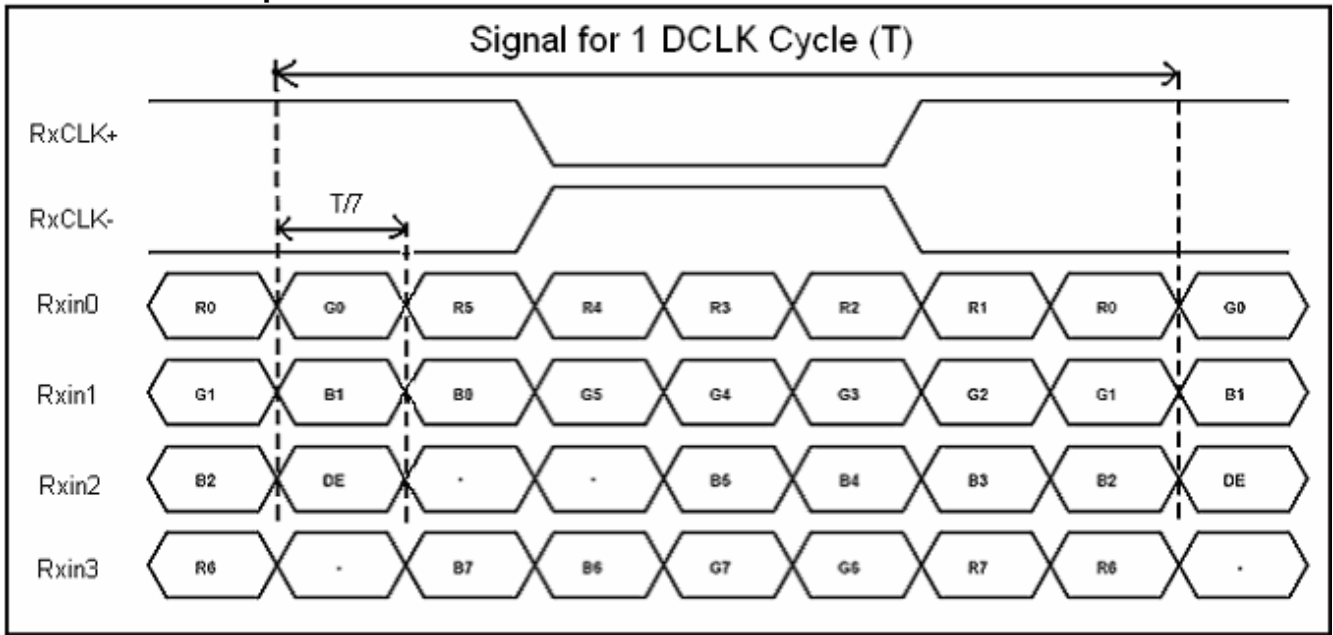

# 7. Optical Characteristics

Item	Symbol	Condition.	Min	Typ.	Max.	Unit	Remark	
Response time	Tr	$\theta=0^\circ, \Phi=0^\circ$	-	10	20	.ms	Note 3	
	Tf		-	15	30			
Contrast ratio	CR	At optimized viewing angle	600	800	-	-	Note 4	
Color Chromaticity	White	$\theta=0^\circ, \Phi=0^\circ$	Wx	0.26	0.31	0.36	-	Note 2,6,7
			Wy	0.28	0.33	0.38	-	
Viewing angle	Hor.	$CR \geq 10$	$\Theta_R$	75	85	-	Deg.	Note 1
			$\Theta_L$	75	85	-		
	Ver.		$\Phi_T$	75	85	-		
			$\Phi_B$	75	85	-		
Brightness	-	-	700	750	-	cd/m <sup>2</sup>	Center of display	
Uniformity	(U)	-	70	-	-	%	Note5	

Ta=25±2°C

Note 1: Definition of viewing angle range

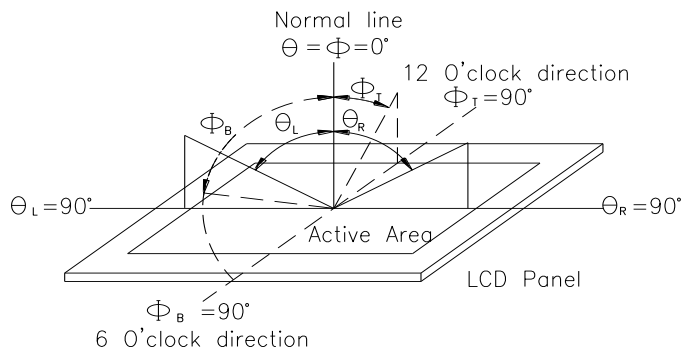

Fig. 7.1. Definition of viewing angle

Note 2: Test equipment setup:

After stabilizing and leaving the panel alone at a driven temperature for 10 minutes, the measurement should be executed. Measurement should be executed in a stable, windless, and dark room. Optical specifications are measured by Topcon BM-7 or BM-5 luminance meter 1.0° field of view at a distance of 50cm and normal direction.

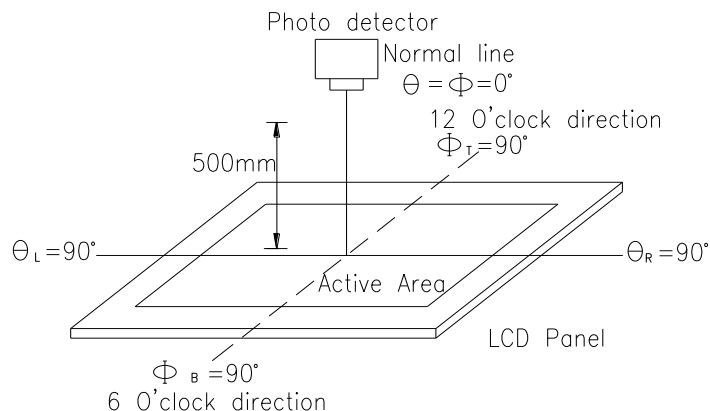
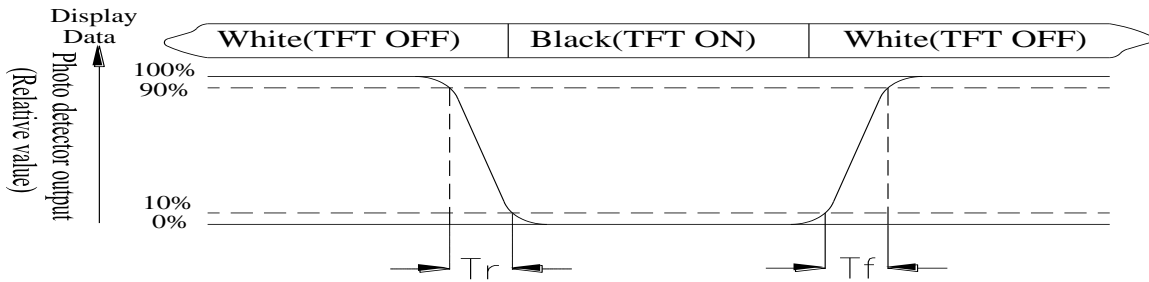

Fig. 7.2. Optical measurement system setup

Note 3: Definition of Response time:

The response time is defined as the LCD optical switching time interval between “White” state and “Black” state. Rise time,  $T_r$ , is the time between photo detector output intensity changed from 90% to 10%. And fall time,  $T_f$ , is the time between photo detector output intensity changed from 10% to 90%



Note 4: Definition of contrast ratio:

The contrast ratio is defined as the following expression.

$$\text{Contrast ratio (CR)} = \frac{\text{Luminance measured when LCD on the "White" state}}{\text{Luminance measured when LCD on the "Black" state}}$$

Note 5: Definition of Luminance Uniformity

Active area is divided into 9 measuring areas (reference the picture in below). Every measuring point is placed at the center of each measuring area.

Luminance Uniformity (U) =  $L_{\min}/L_{\max} \times 100\%$

L = Active area length

W = Active area width

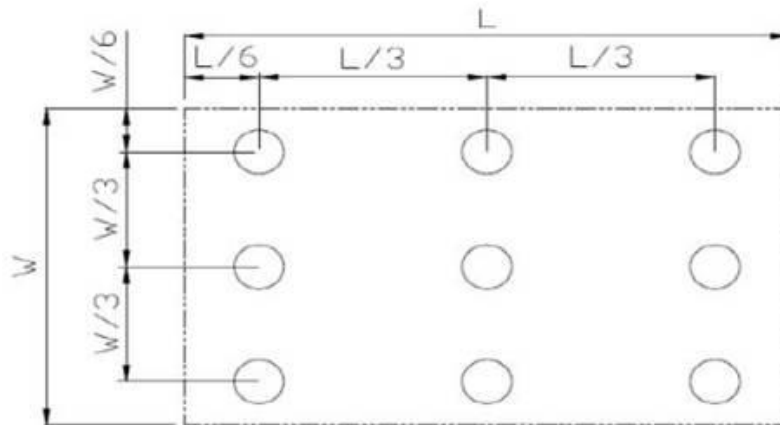

Fig 7.3. Definition of uniformity

Note 6: Definition of color chromaticity (CIE 1931)

Color coordinates measured at the center point of LCD

Note 7: Measured at the center area of the panel when all the input terminals of LCD panel are electrically opened.

# 8.Interface

## 8.1. CON5/CON6

Pin No.	Symbol	Function	Remark
1	3.3V	Raspberry Pi:Power 3.3V	
2	5V	Raspberry Pi:Power 5V	
3	GPIO02	Raspberry Pi:GPIO02	
4	5V	Raspberry Pi:Power 5V	
5	GPIO03	Raspberry Pi:GPIO03	
6	GND	Raspberry Pi:GND	
7	GPIO04	Raspberry Pi:GPIO04	
8	GPIO14	Raspberry Pi:GPIO14	
9	GND	Raspberry Pi:GND	
10	GPIO15	Raspberry Pi:GPIO15	
11	GPIO17	Raspberry Pi:GPIO17	
12	GPIO18	Raspberry Pi:GPIO18 (Backlight Enable)	
13	GPIO27	Raspberry Pi:GPIO27	
14	GND	Raspberry Pi:GND	
15	GPIO22	Raspberry Pi:GPIO22	
16	GPIO23	Raspberry Pi:GPIO23	
17	3.3V	Raspberry Pi:3.3V	
18	GPIO24	Raspberry Pi:GPIO24	
19	GPIO10	Raspberry Pi:GPIO10	
20	GND	Raspberry Pi:GND	
21	GPIO09	Raspberry Pi:GPIO09	
22	GPIO25	Raspberry Pi:GPIO25	
23	GPIO11	Raspberry Pi:GPIO11	
24	GPIO08	Raspberry Pi:GPIO08	
25	GND	Raspberry Pi:GND	
26	GPIO07	Raspberry Pi:GPIO07	
27	ID_SD	Raspberry Pi:ID_SD	
28	ID_SC	Raspberry Pi:ID_SC	
29	GPIO05	Raspberry Pi:GPIO05	
30	GND	Raspberry Pi:GND	

31	GPIO06	Raspberry Pi:GPIO06	
32	GPIO12	Raspberry Pi:GPIO12	
33	GPIO13	Raspberry Pi:GPIO13	
34	GND	Raspberry Pi:GND	
35	GPIO19	Raspberry Pi:GPIO19	
36	GPIO16	Raspberry Pi:GPIO16	
37	GPIO26	Raspberry Pi:GPIO26	
38	GPIO20	Raspberry Pi:GPIO20	
39	GND	Raspberry Pi:GND	
40	GPIO21	Raspberry Pi:GPIO21	

## 8.2. HDMI

Pin No.	Symbol	I/O	Function	Remark
1	Rx2+	I	+LVDS Differential Data Input	
2	GND	P	Ground	
3	Rx2-	I	-LVDS Differential Data Input	
4	Rx1+	I	+LVDS Differential Data Input	
5	GND	P	Ground	
6	Rx1-	I	-LVDS Differential Data Input	
7	Rx0+	I	+LVDS Differential Data Input	
8	GND	P	Ground	
9	Rx0-	I	-LVDS Differential Data Input	
10	RxC+	I	+LVDS Differential Clock Input	
11	GND	P	Ground	
12	RxC-	I	-LVDS Differential Clock Input	
13-14	NC	-	No connection	
15	SCL	I/O	DDC(Data Display Channel) Clock	
16	SDA	I/O	DDC(Data Display Channel) Data	
17	GND	P	Ground	
18	5V	P	Power Supply	
19	Detect	I/O	Hot plug detect	

I: input, O: output, P: Power



### 8.3. USB

Pin	Symbol	Function	Remark
1	5V	Power Supply (5V)	
2	D-	Data line -	
3	D+	Data line +	
4	NC	No connection	
5	GND	Power Ground	

### 8.4. POWER-JACK

Pin No.	Symbol	I/O	Function	Remark
1	5V	P	Power Supply	
2	GND	P	Ground	
3	NC	-	No connection	

### 8.5 RASPBERRY PI COMPATIBILITY

Model	Header Compatibility
Raspberry Pi Model B+	Compatible
Raspberry Pi 2 Model B	Compatible
Raspberry Pi 3 Model B	Compatible
Raspberry Pi 3 Model B+	NOT Compatible*

\* In order to use WF101FSYFPLHTX# directly connected to Raspberry Pi 3 Model B+ header, you need to remove (desolder) U6 – 3.3V LDO.

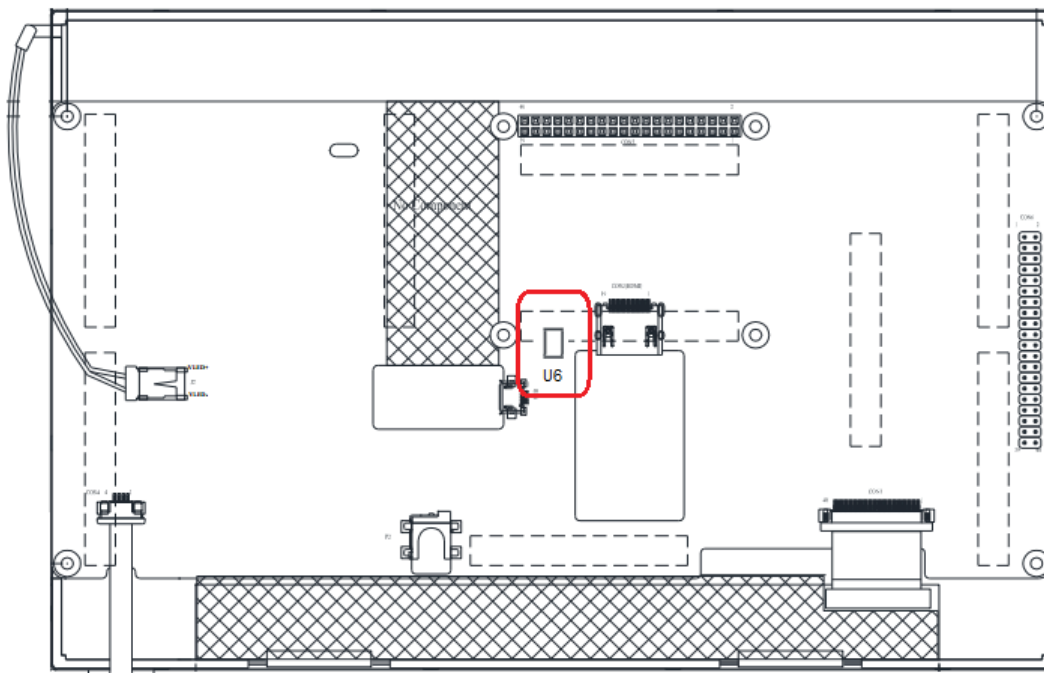

# 9. Reliability

Content of Reliability Test (Wide temperature, -20°C ~70°C)

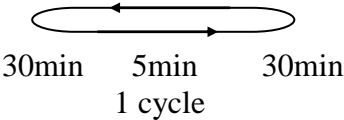
Environmental Test			
Test Item	Content of Test	Test Condition	Note
High Temperature storage	Endurance test applying the high storage temperature for a long time.	70°C 200hrs	2
Low Temperature storage	Endurance test applying the low storage temperature for a long time.	-20°C 200hrs	1,2
High Temperature Operation	Endurance test applying the electric stress (Voltage & Current) and the thermal stress to the element for a long time.	70°C 200hrs	—
Low Temperature Operation	Endurance test applying the electric stress under low temperature for a long time.	-20°C 200hrs	1
High Temperature/ Humidity Operation	The module should be allowed to stand at 60 °C, 90%RH max	60°C, 90%RH 96hrs	1,2
Thermal shock resistance	The sample should be allowed stand the following 10 cycles of operation -20°C    25°C    70°C  30min    5min    30min 1 cycle	-20°C /70°C 10 cycles	—
Vibration test	Endurance test applying the vibration during transportation and using.	Total fixed amplitude : 1.5mm Vibration Frequency : 10~55Hz One cycle 60 seconds to 3 directions of X,Y,Z for Each 15 minutes	3
Static electricity test	Endurance test applying the electric stress to the terminal.	VS=±600V(contact), ±800v(air), RS=330Ω CS=150pF 10 times	—

Note1: No dew condensation to be observed.

Note2: The function test shall be conducted after 4 hours storage at the normal Temperature and humidity after remove from the test chamber.

Note3: The packing have to including into the vibration testing.

# 10.Touch Panel Information

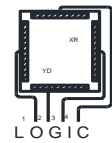
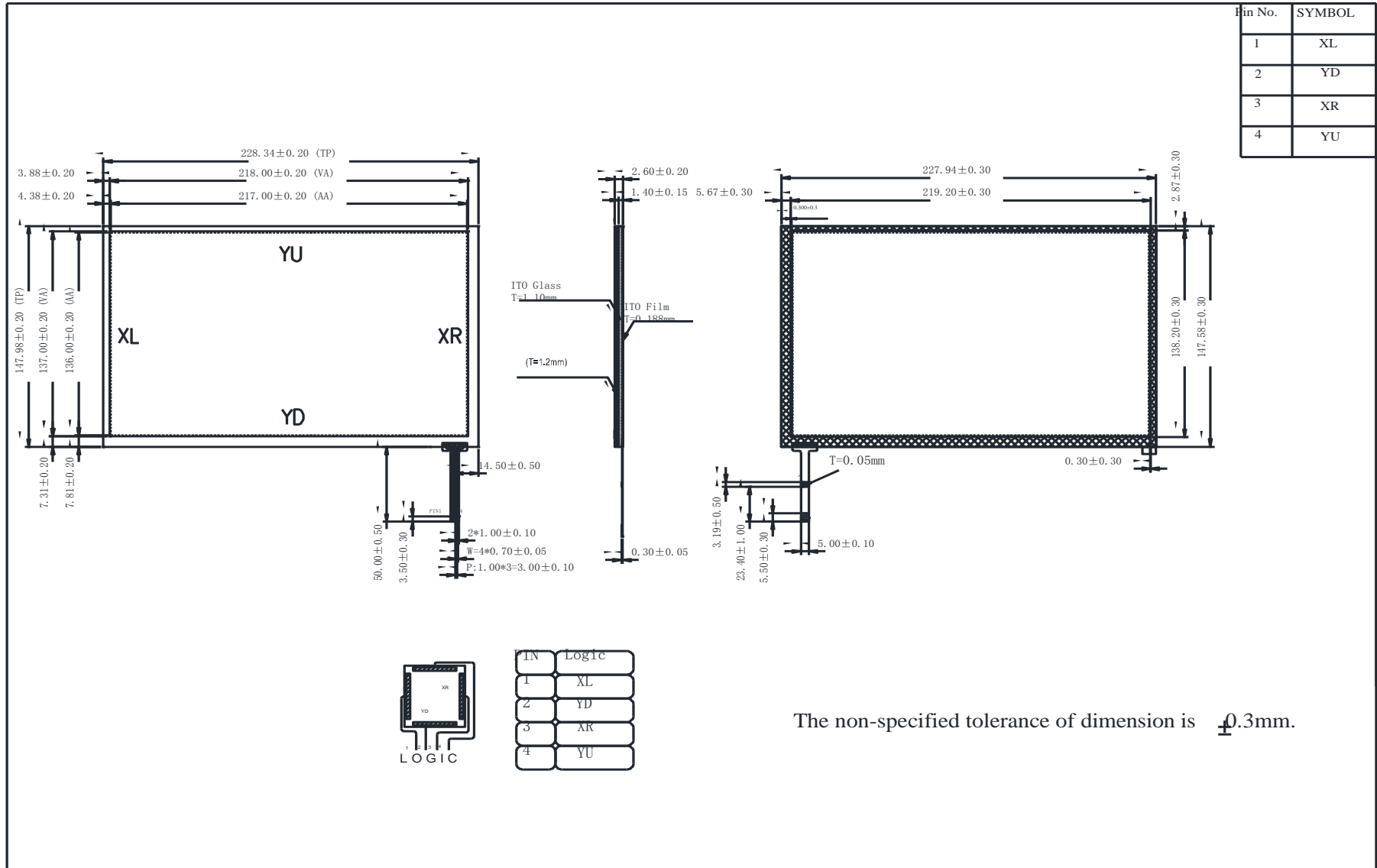

IN	Logic
1	XL
2	YD
3	XR
4	YU

The non-specified tolerance of dimension is  $\pm 0.3\text{mm}$ .

### 10.1. Resistance Touch Panel General Specifications

Item	Description
Driving condition	DC5V
Operating force	20~100g
Linearity max	$\leq \pm 1.5\%$
Insulating resistance	$> 20M\Omega$ , 25V(DC)
Light transparence	70%
Structure type	ITO Film/ITO Glass(F/G)
Surface Hardness	3H typ
Pen Hitting Durability (with the silicon rubber)	$> 1000,000$ times
X resistance	450~1100 $\Omega$
Y resistance	200~600 $\Omega$

# 11. Contour Drawing

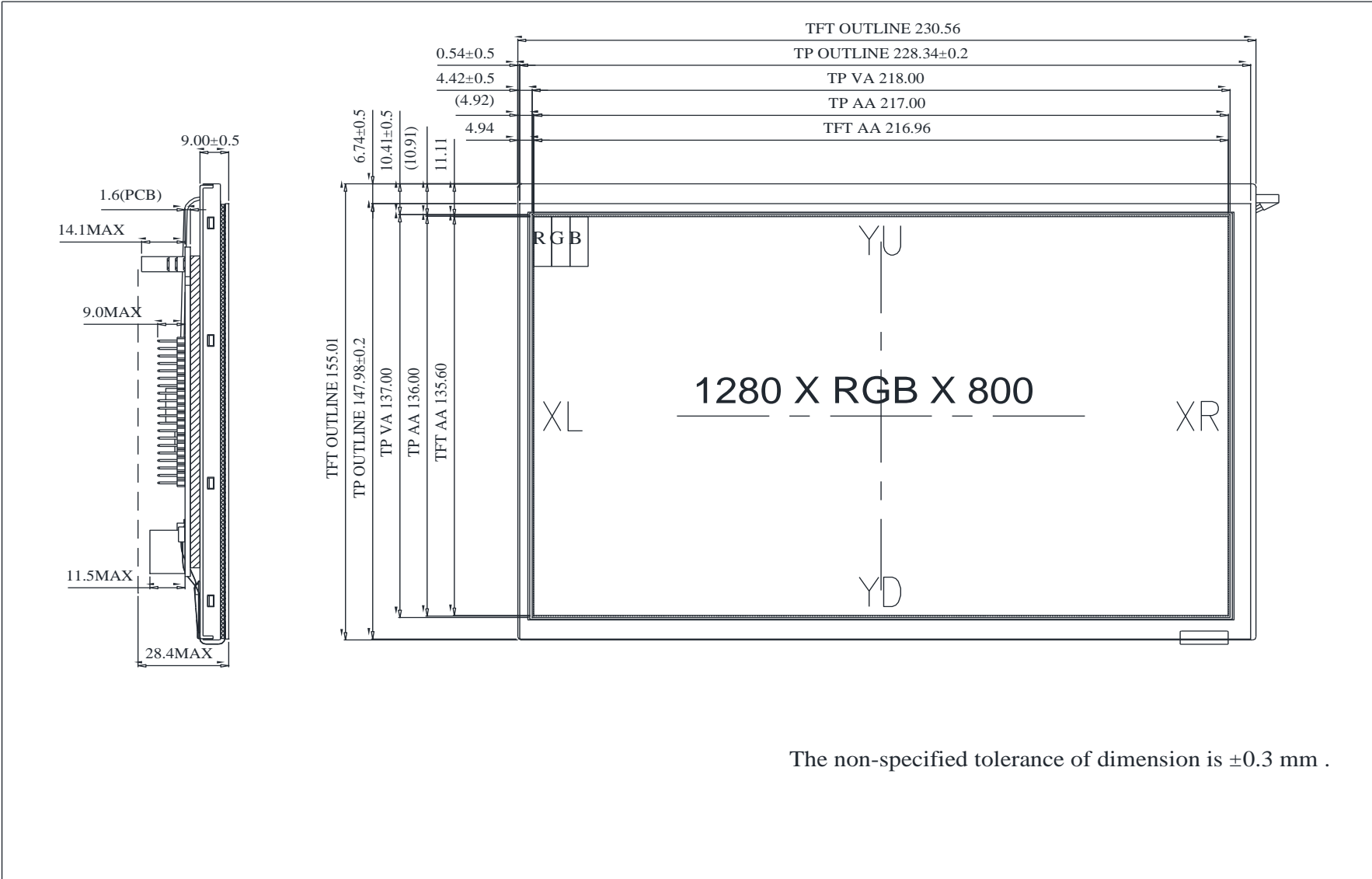

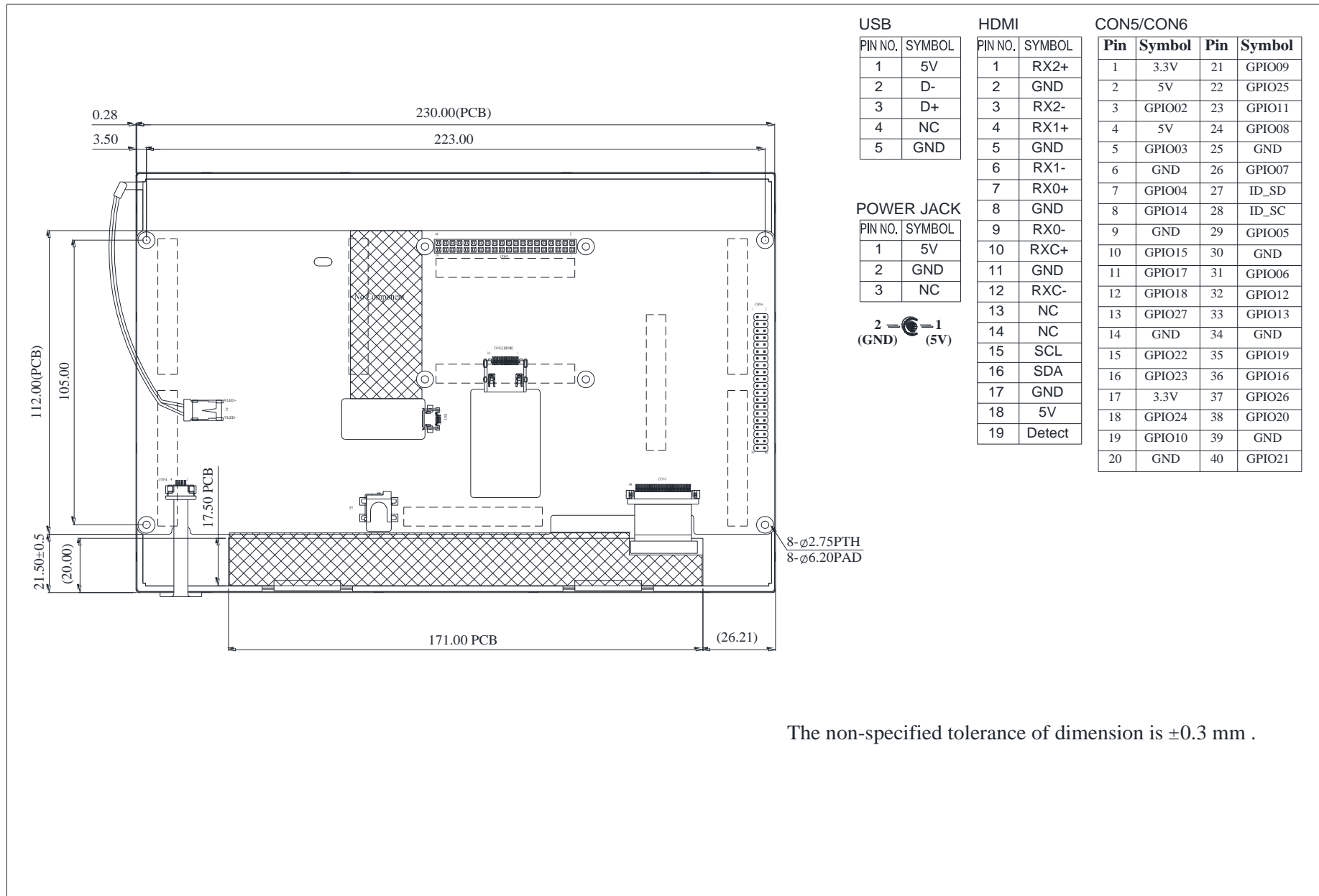

**USB**

PIN NO.	SYMBOL
1	5V
2	D-
3	D+
4	NC
5	GND

**HDMI**

PIN NO.	SYMBOL
1	RX2+
2	GND
3	RX2-
4	RX1+
5	GND
6	RX1-
7	RX0+
8	GND
9	RX0-
10	RXC+
11	GND
12	RXC-
13	NC
14	NC
15	SCL
16	SDA
17	GND
18	5V
19	Detect

**CON5/CON6**

Pin	Symbol	Pin	Symbol
1	3.3V	21	GPIO09
2	5V	22	GPIO25
3	GPIO02	23	GPIO11
4	5V	24	GPIO08
5	GPIO03	25	GND
6	GND	26	GPIO07
7	GPIO04	27	ID_SD
8	GPIO14	28	ID_SC
9	GND	29	GPIO05
10	GPIO15	30	GND
11	GPIO17	31	GPIO06
12	GPIO18	32	GPIO12
13	GPIO27	33	GPIO13
14	GND	34	GND
15	GPIO22	35	GPIO19
16	GPIO23	36	GPIO16
17	3.3V	37	GPIO26
18	GPIO24	38	GPIO20
19	GPIO10	39	GND
20	GND	40	GPIO21

**POWER JACK**

PIN NO.	SYMBOL
1	5V
2	GND
3	NC

2 = = 1 (GND)      1 = = 1 (5V)

The non-specified tolerance of dimension is ±0.3 mm .



**1、Panel Specification :**

- 1. Panel Type :  Pass  NG , \_\_\_\_\_
- 2. View Direction :  Pass  NG , \_\_\_\_\_
- 3. Numbers of Dots :  Pass  NG , \_\_\_\_\_
- 4. View Area :  Pass  NG , \_\_\_\_\_
- 5. Active Area :  Pass  NG , \_\_\_\_\_
- 6. Operating Temperature :  Pass  NG , \_\_\_\_\_
- 7. Storage Temperature :  Pass  NG , \_\_\_\_\_
- 8. Others : \_\_\_\_\_

**2、Mechanical Specification :**

- 1. PCB Size :  Pass  NG , \_\_\_\_\_
- 2. Frame Size :  Pass  NG , \_\_\_\_\_
- 3. Material of Frame :  Pass  NG , \_\_\_\_\_
- 4. Connector Position :  Pass  NG , \_\_\_\_\_
- 5. Fix Hole Position :  Pass  NG , \_\_\_\_\_
- 6. Backlight Position :  Pass  NG , \_\_\_\_\_
- 7. Thickness of PCB :  Pass  NG , \_\_\_\_\_
- 8. Height of Frame to PCB :  Pass  NG , \_\_\_\_\_
- 9. Height of Module :  Pass  NG , \_\_\_\_\_
- 10. Others :  Pass  NG , \_\_\_\_\_

**3、Relative Hole Size :**

- 1. Pitch of Connector :  Pass  NG , \_\_\_\_\_
- 2. Hole size of Connector :  Pass  NG , \_\_\_\_\_
- 3. Mounting Hole size :  Pass  NG , \_\_\_\_\_
- 4. Mounting Hole Type :  Pass  NG , \_\_\_\_\_
- 5. Others :  Pass  NG , \_\_\_\_\_

**4、Backlight Specification :**

- 1. B/L Type :  Pass  NG , \_\_\_\_\_
- 2. B/L Color :  Pass  NG , \_\_\_\_\_
- 3. B/L Driving Voltage (Reference for LED Type) :  Pass  NG , \_\_\_\_\_
- 4. B/L Driving Current :  Pass  NG , \_\_\_\_\_
- 5. Brightness of B/L :  Pass  NG , \_\_\_\_\_
- 6. B/L Solder Method :  Pass  NG , \_\_\_\_\_
- 7. Others :  Pass  NG , \_\_\_\_\_

>> **Go to page 2** <<



Winstar      Module Number : \_\_\_\_\_

Page: 2

**5、Electronic Characteristics of Module :**

- 1. Input Voltage :                       Pass                       NG , \_\_\_\_\_
- 2. Supply Current :                       Pass                       NG , \_\_\_\_\_
- 3. Driving Voltage for LCD :            Pass                       NG , \_\_\_\_\_
- 4. Contrast for LCD :                    Pass                       NG , \_\_\_\_\_
- 5. B/L Driving Method :                 Pass                       NG , \_\_\_\_\_
- 6. Negative Voltage Output :            Pass                       NG , \_\_\_\_\_
- 7. Interface Function :                  Pass                       NG , \_\_\_\_\_
- 8. LCD Uniformity :                     Pass                       NG , \_\_\_\_\_
- 9. ESD test :                             Pass                       NG , \_\_\_\_\_
- 10. Others :                               Pass                       NG , \_\_\_\_\_

**6、Summary :**

Sales signature : \_\_\_\_\_

Customer Signature : \_\_\_\_\_

Date :        /        /        \_\_\_\_\_