

HF-LPX30

Low Power WiFi Module User Manual

V 2.5



HF-LPB130



HF-LPT230

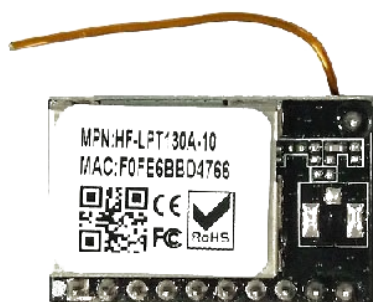

HF-LPT130A



HF-LPT130B

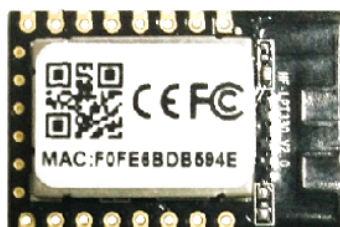

HF-LPT330



HF-LPB135

Overview of Characteristic

- ✧ Support IEEE802.11b/g/n Wireless Standards
- ✧ Based on Cortex-M4 SOC, 160MHz CPU, 352KB RAM for 1MB Flash Version, 384KB for 2MB Flash
- ✧ Support UART Data Communication Interface, baud rate up to 4Mbps
- ✧ Support Work As STA/AP/AP+STA Mode
- ✧ Support SmartLink V8 Function (Provide APP SDK)

- ◇ **Support SmartAPLink Function**
- ◇ **Support WeChat Airkiss 2.0, MiniAPP Config**
- ◇ **Support Wireless and Remote Firmware Upgrade Function**
- ◇ **Support Software SDK for Develop**
- ◇ **Support Different Antenna Option**
 - **HF-LPB130: Internal PCB or External IPEX**
 - **HF-LPT230: Internal PCB or External IPEX**
 - **HF-LPT130A: Internal Copper Line Antenna or External IPEX**
 - **HF-LPT130B: Internal PCB**
 - **HF-LPT330: Internal PCB**
 - **HF-LPB135: Internal PCB or External IPEX**
- ◇ **Single +3.3V Power Supply for HF-LPB130, HF-LPT130A, HF-LPT130B, HF-LPT230, HF-LPT330**
- ◇ **Single +5V Power Supply for HF-LPB135**
- ◇ **Small Size:**
 - **HF-LPB130: 23.1mm x 32.8mm x 3.5mm, SMT34 package**
 - **HF-LPT230: 22mm x 13.5mm x 3mm, SMT18 package**
 - **HF-LPT130A: 22mm x 14.3mm x 8mm, DIP10 package**
 - **HF-LPT130B: 22mm x 15.6mm x 8mm, DIP10 package**
 - **HF-LPT330: 24mm x 16mm x 3mm, SMT16 package**
 - **HF-LPB135: 41.3mm x 24.1mm x 6mm, 4Pin 2.54mm connector**
- ◇ **FCC/CE/SRRC/RoHS Certificated**

TABLE OF CONTENTS

LIST OF FIGURES	8
LIST OF TABLES	10
HISTORY	11
1. PRODUCT OVERVIEW	12
1.1. General Description	12
1.1.1 Key Application	12
1.1.2 Device Parameters	13
1.2. Hardware Introduction	14
1.2.1. HF-LPB130 Pins Definition	16
1.2.2. HF-LPT230 Pins Definition	18
1.2.3. HF-LPT130A&B Pins Definition	19
1.2.4. HF-LPT330 Pins Definition	20
1.2.5. HF-LPB135 Pins Definition	22
1.2.6. Electrical Characteristics	24
1.2.7. HF-LPB130 Mechanical Size.....	25
1.2.8. HF-LPT230 Mechanical Size	26
1.2.9. HF-LPT130A Mechanical Size.....	27
1.2.10. HF-LPT130B Mechanical Size	28
1.2.11. HF-LPT330 Mechanical Size	29
1.2.12. HF-LPB135 Mechanical Size	30
1.2.13. HF-LPB130 On-board PCB Antenna	30
1.2.14. HF-LPT230/HF-LPT330 On-board Chip Antenna	31
1.2.15. HF-LPT130A&B On-board Chip Antenna	32
1.2.16. External Antenna.....	33
1.2.17. Evaluation Kit	33
1.2.18. Order Information	35
1.2.19. Hardware Typical Application.....	37
2. FUNCTIONAL DESCRIPTION	39
2.1. Wireless Networking	39
2.1.1. Basic Wireless Network Based On AP	39
2.1.2. Wireless Network Based On STA.....	39
2.2. Work Mode : Transparent Transmission Mode	40
2.3. Registration Package Function	40
2.4. Heartbeat Package Function	41
2.5. SOCKA HTTP Mode	42
2.6. SOCKA MQTT Mode	45
2.7. UART Frame Scheme	46
2.8. Encryption	46
2.9. Parameters Configuration	47

2.10.	Firmware Update	47
2.11.	SOCKB Function	47
2.12.	Multi-TCP Link Connection	48
2.13.	Event Notification Function	48
3.	OPERATION GUIDELINE	49
3.1.	Configuration	49
3.1.1.	Open Web Management Interface	49
3.1.2.	System Page.....	50
3.1.3.	Work Mode Page	51
3.1.4.	STA Setting Page	51
3.1.5.	AP Setting Page	53
3.1.6.	Other Setting Page	53
3.1.7.	Account Management Page	54
3.1.8.	Upgrade Software Page	54
3.1.9.	Restart Page	54
3.1.10.	Restore Page	55
3.1.11.	Internal Webpage	55
3.2.	Usage Introduction	56
3.2.1.	Software Debug Tools	56
3.2.2.	Network Connection	56
3.2.3.	Default Parameter Setting	56
3.2.4.	Module Debug.....	57
3.3.	Typical Application Examples	58
3.3.1.	Wireless Control Application.....	58
3.3.2.	Remote Management Application.....	59
3.3.3.	Transparent Serial Port Application	59
4.	AT+INSTRUCTION INTRODUCTION	60
4.1.	Configuration Mode	60
4.1.1.	Switch to Configuration Mode.....	60
4.1.2.	Send AT Command in Transparent Transmission Mode	61
4.2.	AT+Instruction Set Overview	61
4.2.1.	Instruction Syntax Format.....	62
4.2.2.	AT+Instruction Set	63
4.2.2.1.	AT+	65
4.2.2.2.	AT+E	65
4.2.2.3.	AT+CMDPW.....	66
4.2.2.4.	AT+WEL	66
4.2.2.5.	AT+EVENT	66
4.2.2.6.	AT+WMODE	67
4.2.2.7.	AT+ENTM	67
4.2.2.8.	AT+TMODE.....	67
4.2.2.9.	AT+MID	68
4.2.2.10.	AT+VER.....	68

4.2.2.11.	AT+BVER	68
4.2.2.12.	AT+HWVER.....	68
4.2.2.13.	AT+RELD	68
4.2.2.14.	AT+FCLR.....	69
4.2.2.15.	AT+Z	69
4.2.2.16.	AT+H	69
4.2.2.17.	AT+CFGTF	69
4.2.2.18.	AT+UART	69
4.2.2.19.	AT+PING	70
4.2.2.20.	AT+NETP	70
4.2.2.21.	AT+NETPIDEN.....	71
4.2.2.22.	AT+NETPID.....	72
4.2.2.23.	AT+MAXSK	72
4.2.2.24.	AT+TCPLK	72
4.2.2.25.	AT+TCPTO.....	72
4.2.2.26.	AT+TCPDIS.....	73
4.2.2.27.	AT+SEND	73
4.2.2.28.	AT+RECV	74
4.2.2.29.	AT+SOCKB	74
4.2.2.30.	AT+TCPDISB	74
4.2.2.31.	AT+TCPTOB	75
4.2.2.32.	AT+TCPLKB.....	75
4.2.2.33.	AT+SNDB	75
4.2.2.34.	AT+RCVB	76
4.2.2.35.	AT+UDPLCPT	76
4.2.2.36.	AT+NREGEN.....	76
4.2.2.37.	AT+NREGDT	76
4.2.2.38.	AT+NREGSND.....	77
4.2.2.39.	AT+HEART	77
4.2.2.40.	AT+HTPTP	78
4.2.2.41.	AT+HTPURL.....	78
4.2.2.42.	AT+HTPHEAD.....	78
4.2.2.43.	AT+MQTOPIC	79
4.2.2.44.	AT+MQLOGIN	79
4.2.2.45.	AT+MQID.....	79
4.2.2.46.	AT+WSSSID.....	80
4.2.2.47.	AT+WSKEY	80
4.2.2.48.	AT+WANN	80
4.2.2.49.	AT+WSMAC	81
4.2.2.50.	AT+WSLK.....	81
4.2.2.51.	AT+WSLKO	81
4.2.2.52.	AT+WSLQ	82
4.2.2.53.	AT+WSCAN.....	82
4.2.2.54.	AT+WSDNS.....	82

4.2.2.55.	AT+LANN	83
4.2.2.56.	AT+WAMAC	83
4.2.2.57.	AT+WAP	83
4.2.2.58.	AT+WAKEY	84
4.2.2.59.	AT+WADHCP	84
4.2.2.60.	AT+WALK	85
4.2.2.61.	AT+WALKIND	85
4.2.2.62.	AT+WAPMXSTA	85
4.2.2.63.	AT+MDCH	85
4.2.2.64.	AT+OTA	86
4.2.2.65.	AT+UPURL	86
4.2.2.66.	AT+DISPS	86
4.2.2.67.	AT+PLANG	87
4.2.2.68.	AT+WEBU	87
4.2.2.69.	AT+NTPRF	87
4.2.2.70.	AT+NTPEN	88
4.2.2.71.	AT+NTPTM	88
4.2.2.72.	AT+NTPSER	89
4.2.2.73.	AT+WRMID	89
4.2.2.74.	AT+ASWD	89
4.2.2.75.	AT+SMTLK	89
4.2.2.76.	AT+WPS	89
4.2.2.77.	AT+NDBG	90
4.2.2.78.	AT+TYPE	90
4.2.2.79.	AT+SMEM	90
4.2.2.80.	AT+WIFI	91
4.2.2.81.	AT+SMARTAPCONFIG	91
4.2.2.82.	AT+SMARTAPSTART	91
4.2.2.83.	AT+BTWAIT	92
4.2.2.84.	AT+DTIM	92
5.	PACKAGE INFORMATION	93
5.1.	Recommended Reflow Profile	93
5.2.	Device Handling Instruction (Module IC SMT Preparation)	93
5.3.	HF-LPB130/HF-LPT230 Shipping Information	94
5.4.	HF-LPT130A Shipping Information	94
	APPENDIX A: HW REFERENCE DESIGN	95
	APPENDIX B: HTTP PROTOCOL TRANSFER	96
	B.1. Sending HTTP Raw Data in Throughput Mode	96
	APPENDIX C: REFERENCES	97
	C.1. High-Flying Mass Production Tool	97
	C.2. SmartLink APP V8 Sniffer Config Tool	97
	C.3. SDK	97

C.4. SmartAPLink APP	97
APPENDIX D: CONTACT INFORMATION	98

LIST OF FIGURES

Figure 1.	HF-LPB130-1 Appearance	14
Figure 2.	HF-LPT230-1 and HF-LPT230-0 Appearance	14
Figure 3.	HF-LPT230-2 Appearance	15
Figure 4.	HF-LPT130A-10 and HF-LPT130B-10 Appearance	15
Figure 5.	HF-LPT330-1 Appearance	15
Figure 6.	HF-LPB135-10 Appearance	16
Figure 7.	HF-LPB130 Pins Map	16
Figure 8.	HF-LPT230 Pins Map	18
Figure 9.	HF-LPT230-2 Antenna Pin	19
Figure 10.	HF-LPT130A&B Pins Map	19
Figure 11.	HF-LPT330 Pins Map	21
Figure 12.	HF-LPB135 Pins Map	22
Figure 13.	HF-LPB130 Mechanical Dimension	25
Figure 14.	HF-LPT230 Mechanical Dimension	26
Figure 15.	HF-LPT130A Mechanical Dimension	27
Figure 16.	HF-LPT130B Mechanical Dimension	28
Figure 17.	HF-LPT330 Mechanical Dimension	29
Figure 18.	HF-LPB135 Mechanical Dimension	30
Figure 19.	Suggested Module Placement Region	31
Figure 20.	Suggested Module Placement Region	32
Figure 21.	HF-LPT130A suggested Module Placement Region	33
Figure 22.	HF-LPB130 EVK	34
Figure 23.	HF-LPT230 EVK	34
Figure 24.	HF-LPB130 Order Information	35
Figure 25.	HF-LPT230 Order Information	35
Figure 26.	HF-LPT130A Order Information	36
Figure 27.	HF-LPT130B Order Information	36
Figure 28.	HF-LPT330 Order Information	36
Figure 29.	HF-LPB135 Order Information	37
Figure 30.	HF-LPX30 Hardware Typical Application	37
Figure 31.	HF-LPX30 Basic Wireless Network Structure	39
Figure 32.	HF-LPX30 STA Network Structure	39
Figure 33.	Transparent Transmission Mode Registration Packet Function Transmission	41
Figure 34.	Transparent Transmission Mode Registration Package Function Example	41
Figure 35.	Transparent Transmission Mode Heartbeat Packet Function Transmission	42
Figure 36.	HTTP Mode Transmission	43
Figure 37.	HTTP GET Request Example	44
Figure 38.	HTTP POST Request Example	45
Figure 39.	MQTT Concept	46
Figure 40.	SOCKB function demo	47
Figure 41.	Two Socket Data Separation	47
Figure 42.	Multi-TCP Link Data Transmission Structure	48

Figure 43.	Open Web Management page.....	49
Figure 44.	1MB Flash Version webpage.....	50
Figure 45.	System Web Page	50
Figure 46.	Work Mode Page	51
Figure 47.	STA Setting Page	52
Figure 48.	STA Scan Page	52
Figure 49.	AP Setting Page	53
Figure 50.	Other Setting Page	53
Figure 51.	Account Page.....	54
Figure 52.	Upgrade SW page	54
Figure 53.	Restart Page	55
Figure 54.	Restore Page	55
Figure 55.	Internal Webpage	56
Figure 56.	STA Interface Debug Connection	56
Figure 57.	AP Interface Debug Connection	56
Figure 58.	“CommTools” Serial Debug Tools	57
Figure 59.	“TCPUDPDbg” Tools Create Connection	57
Figure 60.	“TCPUDPDbg” Tools Setting	58
Figure 61.	“TCPUDPDbg” Tools Connection	58
Figure 62.	Wireless Control Application.....	58
Figure 63.	Remote Management Application.....	59
Figure 64.	Transparent Serial Port Application.....	59
Figure 65.	HF-LPX30 Default UART Port Parameters	60
Figure 66.	Switch to Configuration Mode.....	60
Figure 67.	”AT+H” Instruction for Help	62
Figure 68.	Reflow Soldering Profile	93
Figure 69.	HF-LPB130/HF-LPT230 Shipping Information	94
Figure 70.	Shipping Information	94

LIST OF TABLES

Table1.	HF-LPX30 Module Technical Specifications	13
Table2.	HF-LPB130 Pins Definition.....	17
Table3.	HF-LPT230 Pins Definition.....	18
Table4.	HF-LPT130A&B Pins Definition.....	20
Table5.	HF-LPT330 Pins Definition.....	21
Table6.	HF-LPB135 Pins Definition.....	22
Table7.	Absolute Maximum Ratings:.....	24
Table8.	Power Supply & Power Consumption:	24
Table9.	HF-LPX30 External Antenna Parameters	33
Table10.	HF-LPX30 Evaluation Kit Interface Description	34
Table11.	Event Notification	48
Table12.	HF-LPX30 Web Access Default Setting.....	49
Table13.	Error Code Description	63
Table14.	AT+Instruction Set List	63
Table15.	Reflow Soldering Parameter	93

HISTORY

- Ed. V0.2** 07-25-2017 Internal Version.
- Ed. V0.2** 08-22-2017 Release Version
- Ed. V1.1** 13-10-2017 Add HF-LPT130A type module
- Ed. V1.2** 10-11-2017 Add HF-LPB130 type module
- Ed. V1.3** 03-01-2018 Update HF-LPT230 Pin, webpage config.
- Ed. V1.4** 03-01-2018 Add HF-LPT330 type, correct working temperature,voltage.
- Ed. V1.5** 04-28-2018 Add HF-LPB135 type, add 4.10.14 version software function. Add AT+TMODE, AT+PING, AT+BVER, AT+HWVER, AT+SMEM and others.
- Ed. V1.6** 06-15-2018 Delete 4MB version, add HF-LPT230-0 type
- Ed. V1.7** 08-08-2018 Add HF-LPT230-0 size, add HF-LPT130B type and 4.12.07 firmware new function(AT+CMDPW,AT+MDCH).
- Ed. V1.8** 10-10-2018 Add 4.12.14 version AT+SMARTAPCONFIG, AT+SMARTAPSTART, AT+BTWAIT command
- Ed. V1.9** 12-11-2018 Add AT+WLSKO command, fix LPB130 size picture error.
- Ed. V2.0** 04-12-2019 Add WeChat MiniAPP Config, add AT+NTPXXX command, AT+WSDNS, AT+WMAC, AT+DTIM, update AP MAC calculation, update power consumption
- Ed. V2.1** 08-05-2019 Update software 4.13.24 function. Add AT+WEL, AT+EVENT, MQTT, HTTP Function, Heartbeat, registration function.
- Ed. V2.2** 10-28-2019 Add LPT230-2 version.
- Ed. V2.3** 02-13-2020 Add socka HTTP and TCP TLS function, update AT+TCPDIS, AT+MQXX, AT+MQTOPIC, AT+HTPTP command.
- Ed. V2.4** 03-18-2020 Add baud rate 1Mbps ~ 4Mbps support.
- Ed. V2.5** 2022-06-18 Update AT+NTPSER, AT+NTPEN, AT+NTPTM command.

1. PRODUCT OVERVIEW

1.1. General Description

The HF-LPX30 is a fully self-contained small form-factor, single stream, 802.11b/g/n Wi-Fi module, which provide a wireless interface to any equipment with a Serial interface for data transfer. HF-LPX30 integrate MAC, baseband processor, RF transceiver with power amplifier in hardware and all Wi-Fi protocol and configuration functionality and networking stack, in embedded firmware to make a fully self-contained 802.11b/g/n Wi-Fi solution for a variety of applications.

The HF-LPX30 employs the world's lowest power consumption embedded architecture. It has been optimized for all kinds of client applications in the home automation, smart grid, handheld device, personal medical application and industrial control that have lower data rates, and transmit or receive data on an infrequent basis.

The HF-LPX30 series Wi-Fi modules provide different package with different size called HF-LPB130/HF-LPT230/HF-LPT130A/B(T means tiny). It is pin to pin compatible for HF-LPB100/HF-LPB120, HF-LPT200/HF-LPT220, HF-LPT100F/HF-LPT120A modules.

1.1.1 Key Application

- Remote equipment monitoring
- Asset tracking and telemetry
- Security
- Industrial sensors and controls
- Home automation
- Medical devices

1.1.2 Device Parameters

Table1. HF-LPX30 Module Technical Specifications

Class	Item	Parameters
Wireless Parameters	Certification	FCC/CE/SRRC/RoHS
	Wireless standard	802.11 b/g/n
	Frequency range	2.412GHz-2.484GHz
	Transmit Power	802.11b: +16 +/-2dBm (@11Mbps)
		802.11g: +14 +/-2dBm (@54Mbps)
		802.11n: +13 +/-2dBm (@HT20, MCS7)
	Receiver Sensitivity	802.11b: -87 dBm (@11Mbps ,CCK)
802.11g: -73 dBm (@54Mbps, OFDM)		
802.11n: -71 dBm (@HT20, MCS7)		
Antenna Option	HF-LPB130: Internal: PCB antenna External: IPEX antenna HF-LPT230: Internal: PCB antenna External: IPEX antenna HF-LPT130A: Internal: Copper Line antenna External: IPEX antenna HF-LPT130B: Internal: PCB antenna HF-LPT330: Internal: PCB antenna HF-LPB135: Internal: PCB antenna External: IPEX antenna	
Hardware Parameters	Data Interface	UART GPIO,SPI
	Operating Voltage	2.9~4.2V
	Operating Current	Peak (Continuous TX): 260mA Average(STA, No data): 18mA(DTIM=1), 14mA(DTIM=3) Average(STA, Continuous TX): 24mA Average(AP): 80mA Shutdown(reset pull low):60uA
	Operating Temp.	-40°C- 85°C 0°C- 105°C(High Temperate Version)
	Storage Temp.	-40°C- 125°C
	Density	<85%
	Dimensions and Size	HF-LPB130: 23.1mm x 32.8mm x 3.5mm HF-LPT230: 22mm x 13.5mm x 3mm HF-LPT130A: 22mm x 14.3mm x 8mm HF-LPT130B: 22mm x 15.6mm x 8mm HF-LPT330:

		24 mm x 16mm x 3mm HF-LPB135: 41.3mm x 24.1mm x 6mm
Software Parameters	Network Type	STA/AP/AP+STA
	Security Mechanisms	WEP/WPA-PSK/WPA2-PSK
	Encryption	WEP64/WEP128/TKIP/AES
	Update Firmware	Local Wireless, Remote OTA
	Customization	Support SDK for application develop
	Network Protocol	IPv4, TCP/UDP/HTTP/MQTT
	User Configuration	AT+instruction set. Android/ iOS SmartLink APP tools

1.2. Hardware Introduction

HF-LPX30 series Wi-Fi module appearance is as following.



Figure 1. HF-LPB130-1 Appearance

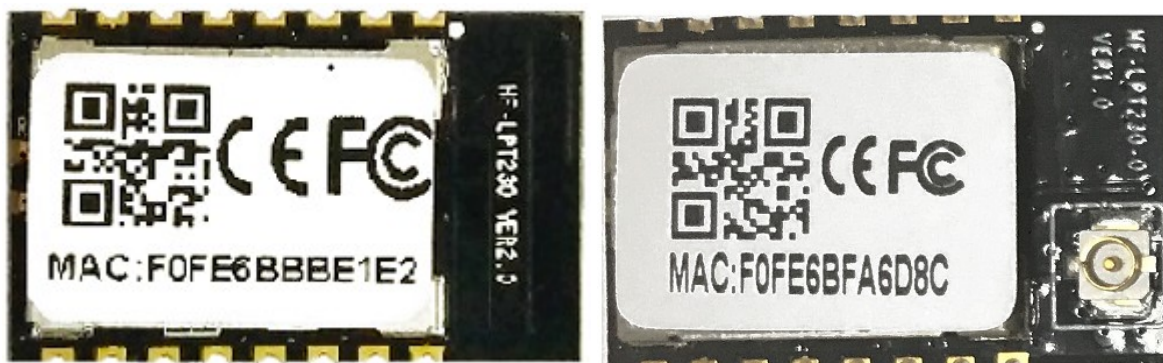

Figure 2. HF-LPT230-1 and HF-LPT230-0 Appearance

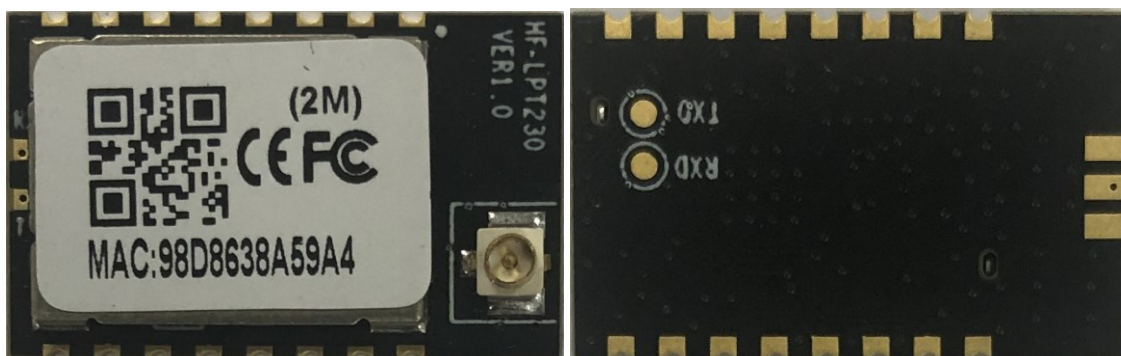

Figure 3. HF-LPT230-2 Appearance

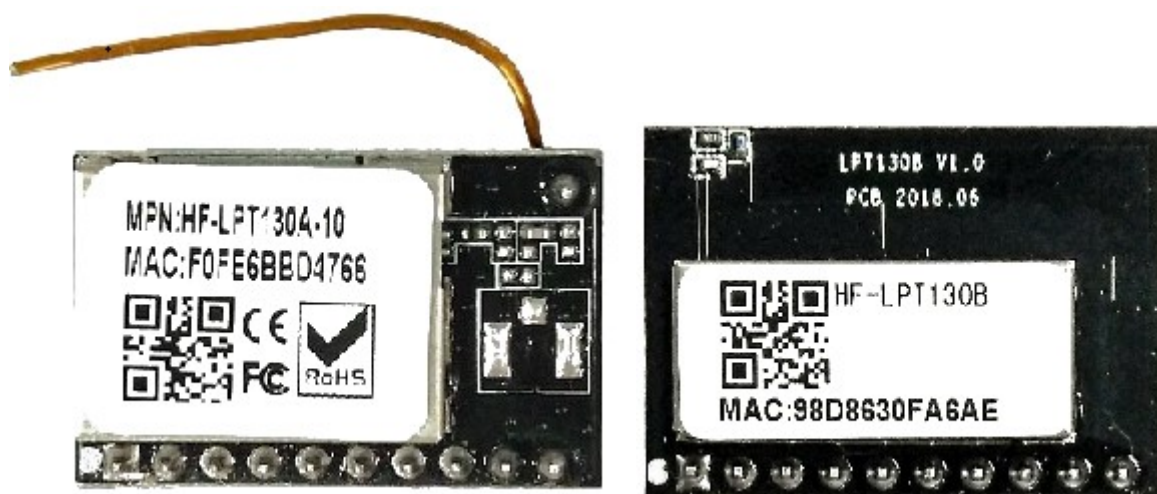

Figure 4. HF-LPT130A-10 and HF-LPT130B-10 Appearance



Figure 5. HF-LPT330-1 Appearance



Figure 6. HF-LPB135-10 Appearance

1.2.1. HF-LPB130 Pins Definition

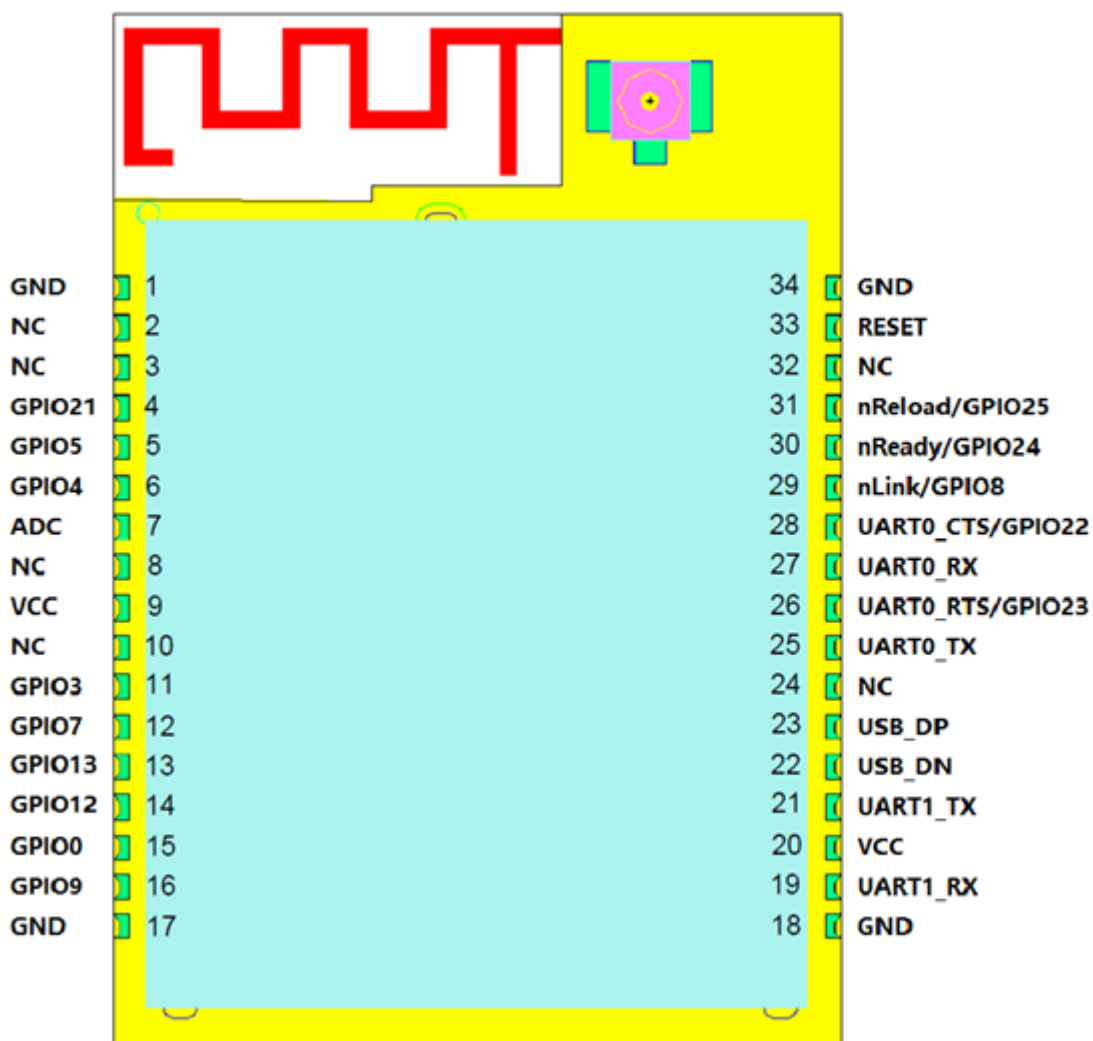

Figure 7. HF-LPB130 Pins Map

Table2. HF-LPB130 Pins Definition

Pin	Description	Net Name	Signal Type	Comments
1,17,18,34	Ground	GND	Power	
2		N.C		
3		N.C		
4	GPIO21	GPIO21	I/O	Output Low when boot
5	GPIO5	GPIO5	IPD/O	Can be used as SPI_CS
6	GPIO4	GPIO4	IPD/O	Can be used as SPI_CLK
7	ADC	ADC	IPD/O	GPADC0,ADC Function
8		N.C		
9,20	+3.3V Power	DVDD	Power	
10		N.C		
11	GPIO3	GPIO3	I/P/U/O	There will be 2ms output low when bootup, after then it works as input pull high. Can be used as PWM4
12	GPIO7	GPIO7	IPD/O	Can be used as SPI_MISO
13	GPIO13	GPIO13	I/O	
14	GPIO12	GPIO12	IPD/O	Can be used as SPI_MOSI
15	GPIO0	GPIO0	I/O	
16	GPIO9	GPIO9	I/O	
19	UART1_RXD	UART1_RXD	I	3.3V UART1 Debug Input GPIO26, Leave it if not use Detailed functions see <Notes>
21	UART1_TXD	UART1_TXD	O	3.3V UART1 Debug Output GPIO27, Leave it if not use Detailed functions see <Notes>
22	USB_DN	USB_DN		
23	USB_DP	USB_DP		
24		N.C		
25	UART0	UART0_TX	O	3.3V UART0 Communication Output GPIO2
26	UART0_RTS	UART0_RTS	I/P/U/O	GPIO23, PWM1
27	UART0	UART0_RX	I	3.3V UART0 Communication Input GPIO1
28	UART0_CTS	UART0_CTS	I/P/U/O	GPIO22, PWM0
29	Wi-Fi Status	nLink	IPD/O	“0” – Wi-Fi connect to router “1” – Wi-Fi unconnected; Detailed functions see <Notes> GPIO8
30	Module Boot Up Indicator	nReady	I/P/U/O	“0” – Boot-up OK; “1” – Boot-up No OK; GPIO24, PWM2
31	Multi-Function	nReload	I/P/U/O	Detailed functions see <Notes> GPIO25, PWM3

Pin	Description	Net Name	Signal Type	Comments
32		N.C		
33	Module Reset	EXT_RESETn	I,PU	“Low” effective reset input. There is RC reset circuit internally. External pull-up resistor is not allowed.

1.2.2. HF-LPT230 Pins Definition

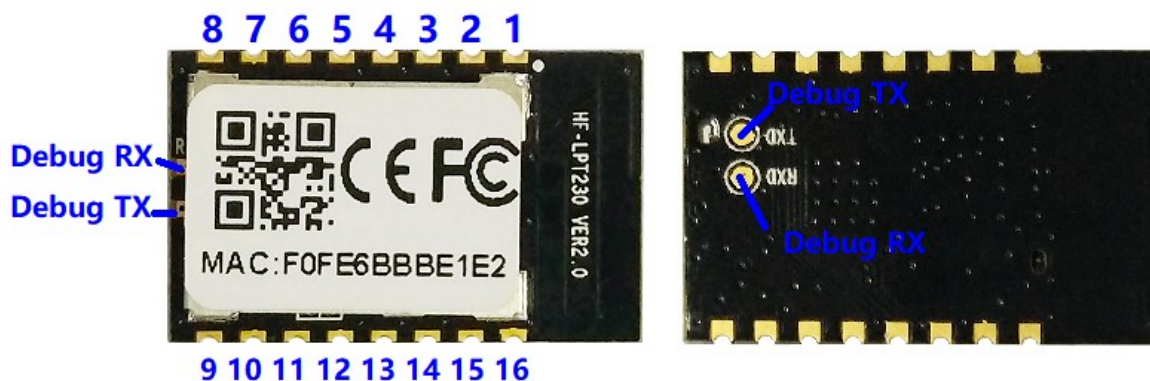

Figure 8. HF-LPT230 Pins Map

Table3. HF-LPT230 Pins Definition

Pin	Description	Net Name	Signal Type	Comments
1	SPI_MOSI	SPI_MOSI	O	GPIO12,
2	SPI_CLK	SPI_CLK	I/O	GPIO4,
3	SPI_MISO	SPI_MISO	I	GPIO7
4	SPI_CS	SPI_CS	I/O	GPIO5,
5	UART0	UART0_TX	O,PU	3.3V UART0 Communication Output GPIO2
6	UART0	UART0_RX	I	3.3V UART0 Communication Input GPIO1
7	UART0_CTS	UART0_CTS	I/O	GPIO22, PWM0
8	UART0_RTS	UART0_RTS	I/O,PU	GPIO23, PWM1
9	ADC	ADC	I/O,PU	GPADC0,ADC function
10	Module Reset	EXT_RESETn	I,PU	“Low” effective reset input. There is RC reset circuit internally. External pull-up resistor is not allowed.
11	Module Boot Up Indicator	nReady	O	“0” – Boot-up OK; “1” – Boot-up No OK; GPIO24, PWM2
12	Multi-Function	nReload	I,PU	Detailed functions see <Notes> GPIO25, PWM3
13	Wi-Fi Status	nLink	O	“0” – Wi-Fi connect to router “1” – Wi-Fi unconnected;

Pin	Description	Net Name	Signal Type	Comments
				Detailed functions see <Notes> GPIO8
14	GPIO3	GPIO3	I/O	GPIO3,PWM4 There will be 2ms output low when bootup, after then it works as input pull high.
15	+3.3V Power	DVDD	Power	
16	Ground	GND	Power	
	Debug RX	UART1_RXD	I	3.3V UART1 Debug Input GPIO26, Leave it if not use
	Debug TX	UART1_TXD	O	3.3V UART1 Debug Output GPIO27, Leave it if not use

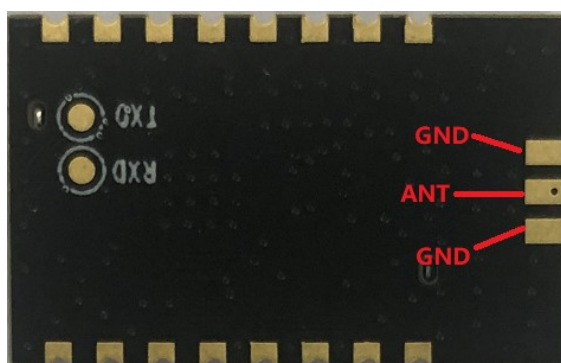

Figure 9. HF-LPT230-2 Antenna Pin

1.2.3. HF-LPT130A&B Pins Definition

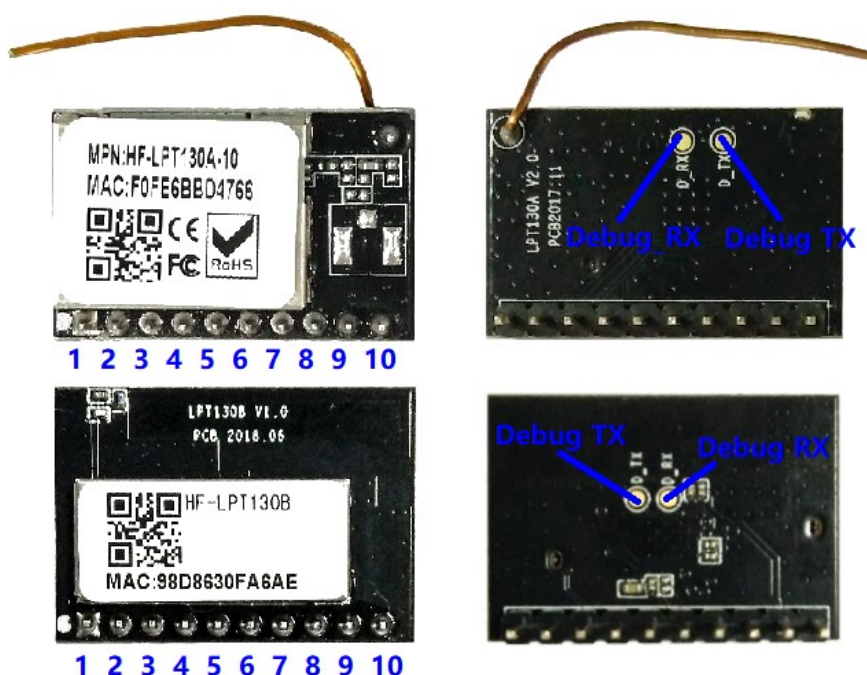

Figure 10. HF-LPT130A&B Pins Map

Table4. HF-LPT130A&B Pins Definition

Pin	Description	Net Name	Signal Type	Comments
1	Ground	GND	Power	
2	+3.3V Power	DVDD	Power	
3	Multi-Function	nReload	I,PU	Detailed functions see <Notes> GPIO3, PWM4 There will be 2ms output low when bootup, after then it works as input pull high.
4	Module Reset	EXT_RESETn	I,PU	“Low” effective reset input. There is RC reset circuit internally. External pull-up resistor is not allowed.
5	UART0	UART0_RX	I	3.3V UART0 Communication Input GPIO1
6	UART0	UART0_TX	O,PU	3.3V UART0 Communication Output GPIO2
7	GPIO25	GPIO25	I/O	GPIO25,PWM3
8	GPIO24	GPIO24	I/O	GPIO24,PWM2
9	Module Boot Up Indicator	nReady	O	“0” – Boot-up OK; “1” – Boot-up No OK; GPIO23, PWM1
10	Wi-Fi Status	nLink	O	“0” – Wi-Fi connect to router “1” – Wi-Fi unconncted; Detailed functions see <Notes> GPIO22,PWM0
	Debug RX	UART1_RX	I	3.3V UART1 Debug Input GPIO26, Leave it if not use
	Debug TX	UART1_TX	O	3.3V UART1 Debug Output GPIO27, Leave it if not use

1.2.4. HF-LPT330 Pins Definition

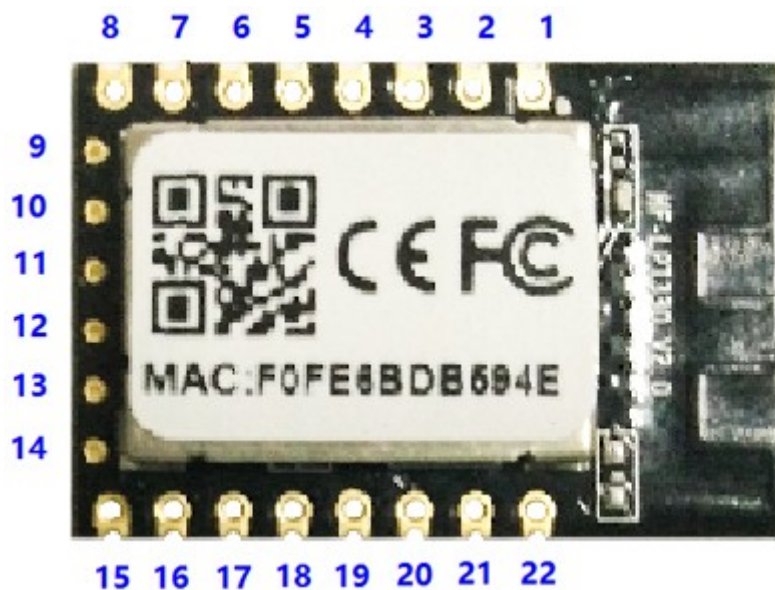

Figure 11. HF-LPT330 Pins Map

Table5. HF-LPT330 Pins Definition

Pin	Description	Net Name	Signal Type	Comments
1	Module Reset	EXT_RESETh	I,PU	“Low” effective reset input. There is RC reset circuit internally. External pull-up resistor is not allowed.
2	ADC	ADC	IPD/O	GPADC0,ADC Function
3	GPIO0	GPIO0	I/O	
4	GPIO13	GPIO13	I/O	
5	Module Boot Up Indicator	nReady	IPU/O	“0” – Boot-up OK; “1” – Boot-up No OK; GPIO24, PWM2
6	UART0_RTS	UART0_RTS	IPU/O	GPIO23, PWM1
7	UART0_CTS	UART0_CTS	IPU/O	GPIO22, PWM0
8	+3.3V Power	DVDD	Power	
9	GPIO21	GPIO21	I/O	Output Low when boot
10	SPI_MOSI	SPI_MOSI	O	GPIO12,
11	SPI_CLK	SPI_CLK	I/O	GPIO4,
12	SPI_CS	SPI_CS	I/O	GPIO5,
13	SPI_MISO	SPI_MISO	I	GPIO7
14	UART1_RXD	UART1_RXD	I	3.3V UART1 Debug Input GPIO26, Leave it if not use Detailed functions see <Notes>
15	Ground	GND	Power	
16	Wi-Fi Status	nLink	IPD/O	“0” – Wi-Fi connect to router “1” – Wi-Fi unconnected; Detailed functions see <Notes> GPIO8
17	UART1_TXD	UART1_TXD	O	3.3V UART1 Debug Output GPIO27, Leave it if not use Detailed functions see <Notes>
18	GPIO9	GPIO9	I/O	GPIO9
19	GPIO3	GPIO3	IPU/O	There will be 2ms output low when bootup, after then it works as input pull high. Can be used as PWM4
20	Multi-Function	nReload	IPU/O	Detailed functions see <Notes> GPIO25, PWM3
21	UART0	UART0_RX	I	3.3V UART0 Communication Input GPIO1
22	UART0	UART0_TX	O	3.3V UART0 Communication Output GPIO2

1.2.5. HF-LPB135 Pins Definition

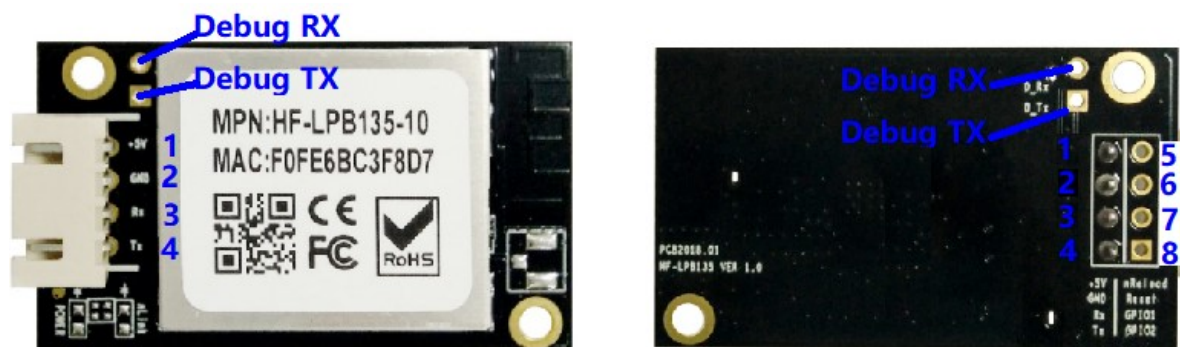

Figure 12. HF-LPB135 Pins Map

Table6. HF-LPB135 Pins Definition

Pin	Description	Net Name	Signal Type	Comments
1	+5V Power	DVDD	Power	5V@300mA
2	Ground	GND	Power	Ground
3	UART0_RX	UART0_RX	I	5V UART0 Communication Input GPIO1
4	UART0_TX	UART0_TX	O	5V UART0 Communication Output GPIO2
5	Multi-Function	nReload	I/P/O	Detailed functions see <Notes> GPIO25, PWM3
6	Module Reset	EXT_RESETn	I,PU	“Low” effective reset input. There is RC reset circuit internally. External pull-up resistor is not allowed.
7	GPIO0	GPIO0	I/O	GPIO0
8	GPIO13	GPIO13	I/O	GPIO13
	Debug RX	UART1_RXD	I	3.3V UART1 Debug Input
	Debug TX	UART1_TXD	O	3.3V UART1 Debug Output

<Notes>

I — Input; O — Output

PU—Internal Resistor Pull Up; I/O: Digital I/O; Power—Power Supply

nReload Pin (Button) function:

1. When this pin is set to “low” during module boot up, the module will enter wireless firmware and config upgrade mode. This mode is used for customer manufacture. (See Appendix to download software tools for customer batch configuration and upgrade firmware during mass production)
2. After module is powered up, short press this button (0.2s < “Low” < 1.5s) and loose to make the module go into “SmartLink “ config mode, waiting for APP to set

password and other information. (See Appendix to download SmartLink V8 and SmartAPLink APP)

3. After module is powered up, long press this button (“Low” > 4s) and loose to make the module recover to factory setting.

High-Flying strongly suggest customer fan out this pin to connector or button for “Manufacture” upgrade or “ SmartLink” application.

nReady Pin (LED) function(Low effective):

1. OS initial finished indicator. Only after this pin output low, can the UART function be used.

nLink Pin (LED) function(Low effective):

1. At wireless firmware and config upgrade mode , this LED used to indicate configure and upgrade status.
2. At “SmartLink” config mode, this LED is used to indicate APP to finish setting.
3. At normal mode, it’s Wi-Fi link status indicator. Output Low when STA mode connect to router AP or other STA connect to it when in AP mode.

High-Flying strongly suggest customer fan out this pin to LED.

PWM function:

PWM0~PWM3 100ns period(if duty is from 0~255, then the maximum frequency is $10M/256=39KHz$), PWM4 support 800ns period.

Due to PWM pin is internal weak pull-up. So when these pins are used for LED bulb application, suggest to add strong pull-down resistor to revert the lulb on when boot.

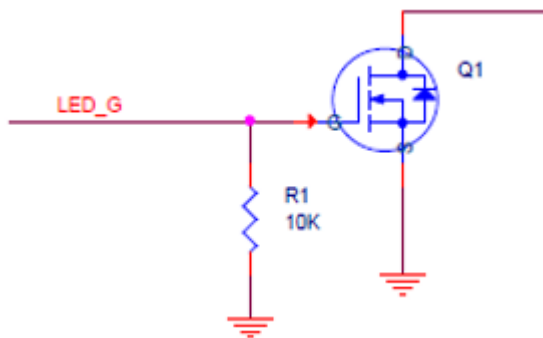

Note: nReload pin is also used for special function, when use this pin for PWM bulb application and add external pull-down resistor, this will cause the module wait 1 second when bootup(wait “space” key to etner bootloader). Contact us to provice special bootloader in order to remove this wait time.

UART1 Debug :

1. Is used for debug log or firmware program, baud rate 921600.
2. Can be used for communication in SDK.

1.2.6. Electrical Characteristics

Table7. Absolute Maximum Ratings:

Parameter	Condition	Min.	Typ.	Max.	Unit
Work temperature range		-40		105	°C
Maximum soldering temperature	IPC/JEDEC J-STD-020			260	°C
ESD (Human Body Model HBM)	TAMB=25°C			2.5	KV
ESD (MM)	TAMB=25°C			0.25	KV

Table8. Power Supply & Power Consumption:

Parameter	Condition	Min.	Typ.	Max.	Unit
Operating Supply voltage		2.9	3.3	4.2	V
Supply current, peak	Continuous Tx		260		mA
Supply current,	STA No data transfer		27		mA
Supply current,	STA Continuous data transfer		35		mA
Supply current,	AP		80		mA
GPIO sink current	GND+0.5V		3		mA
GPIO pull current	VCC-0.5V		3		mA

1.2.7. HF-LPB130 Mechanical Size

HF-LPB130 modules physical size (Unit: mm) as follows:

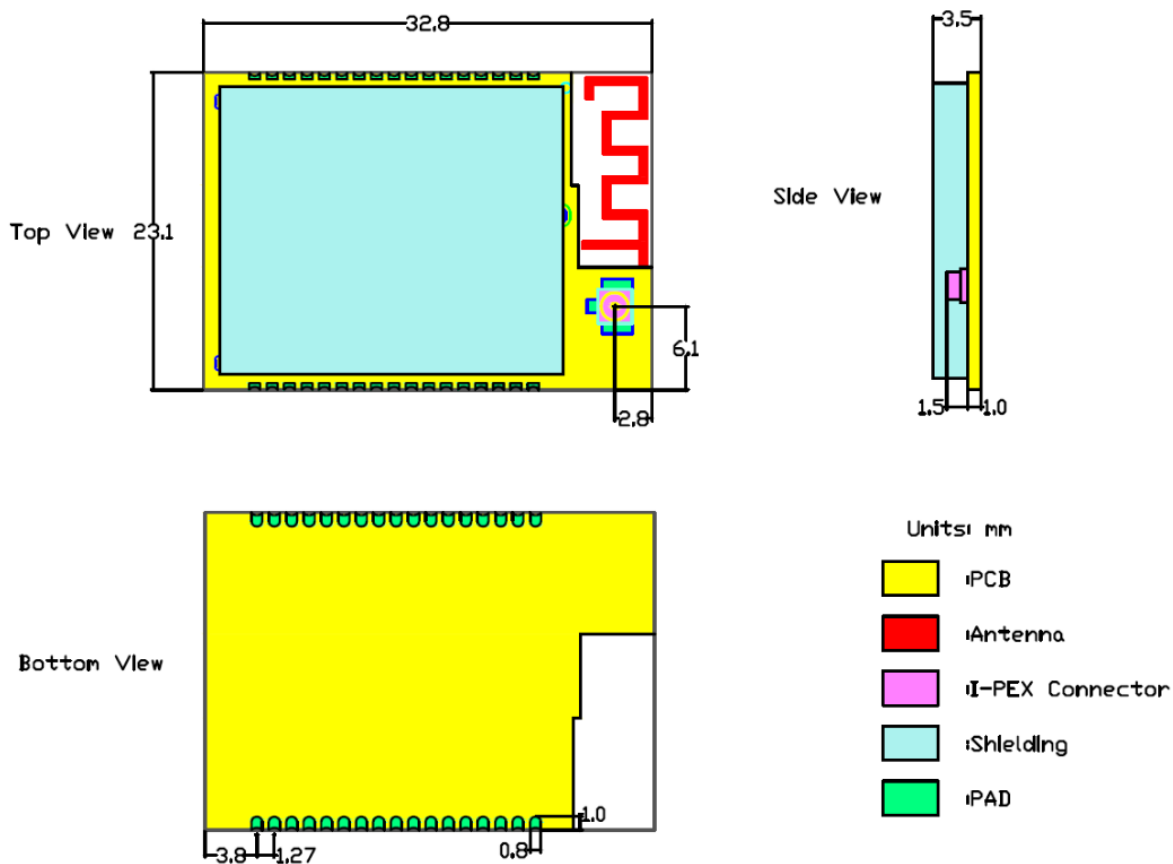

Figure 13. HF-LPB130 Mechanical Dimension

1.2.8. HF-LPT230 Mechanical Size

The size of HF-LPT230-1 and HF-LPT230-0 is the same. HF-LPT230-1 does not have IPEX connector. HF-LPT230 modules physical size (Unit: mm) as follows:

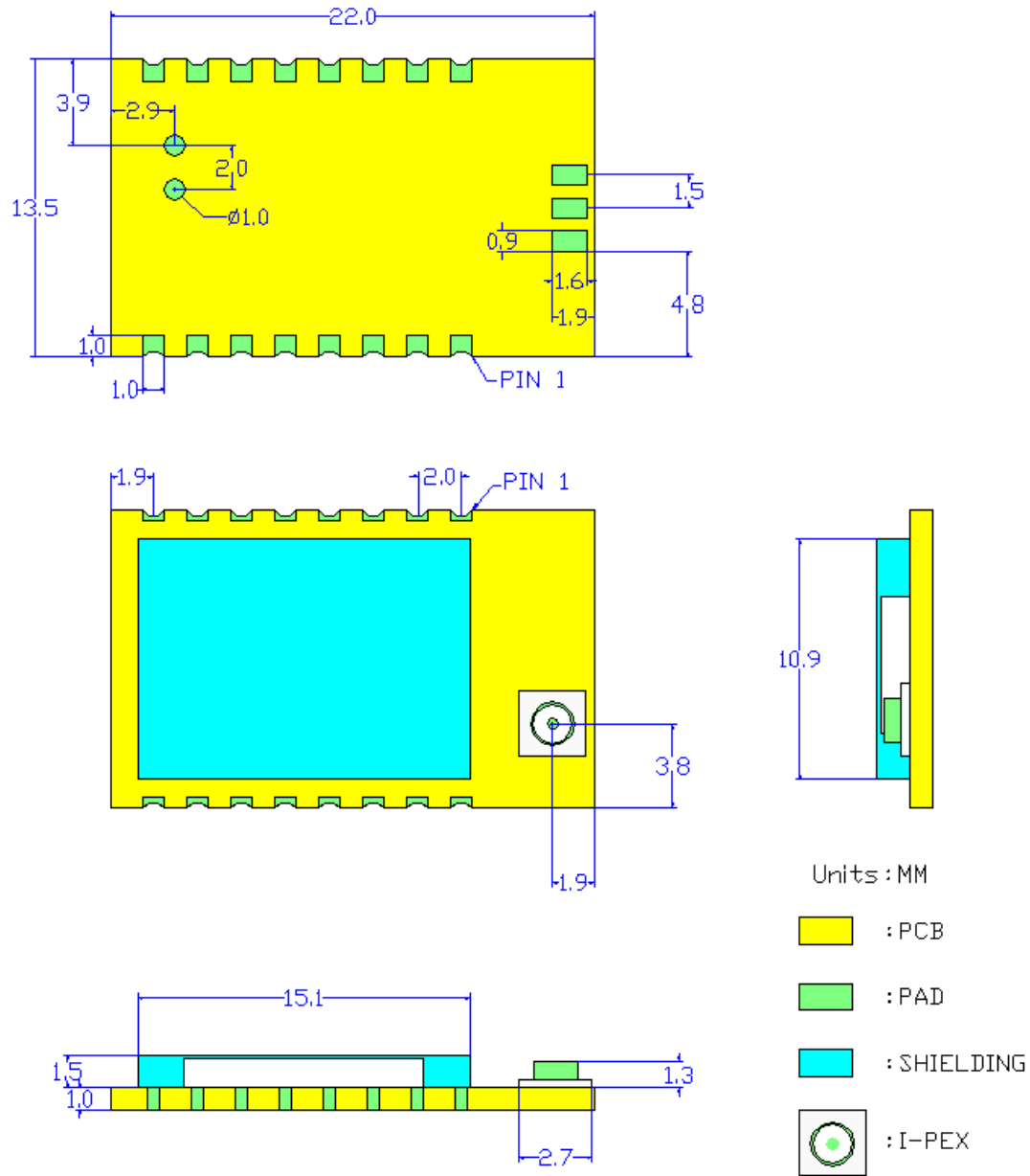

Figure 14. HF-LPT230 Mechanical Dimension

1.2.9. HF-LPT130A Mechanical Size

HF-LPT130A modules physical size (Unit: mm) as follows:

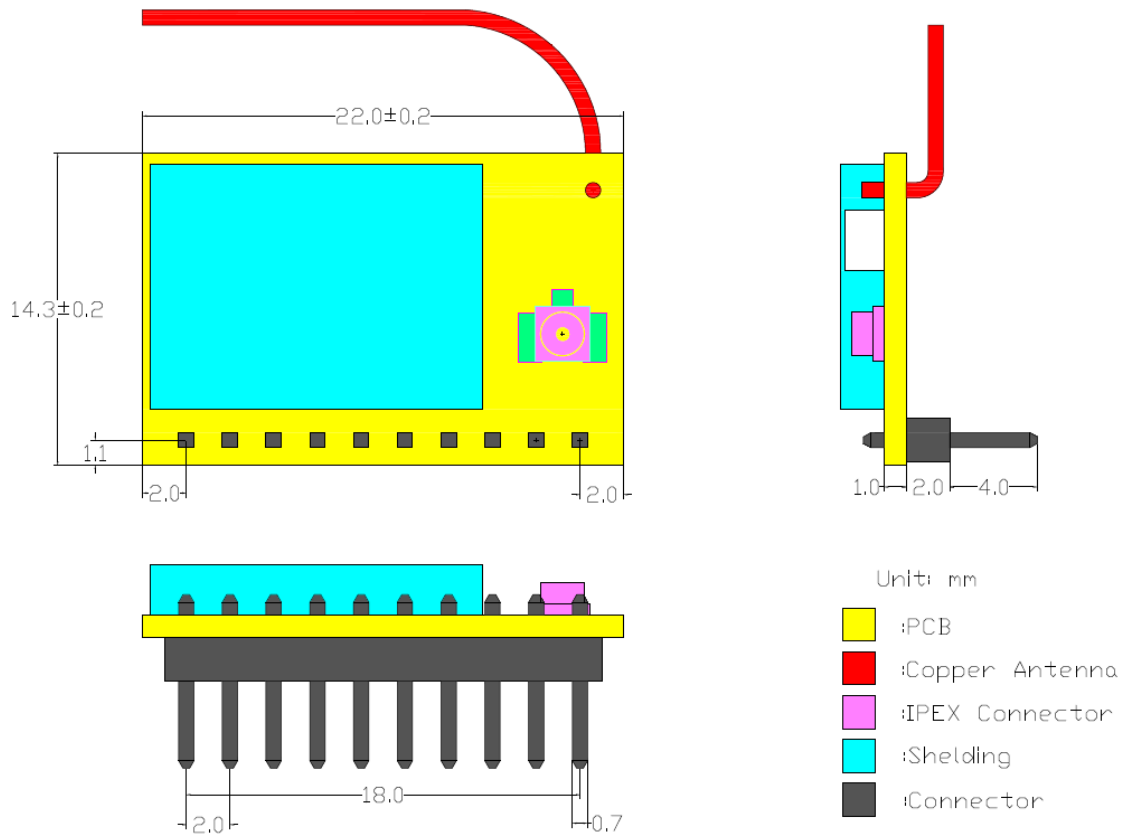

Figure 15. HF-LPT130A Mechanical Dimension

1.2.10. HF-LPT130B Mechanical Size

HF-LPT130B modules physical size (Unit: mm) as follows:

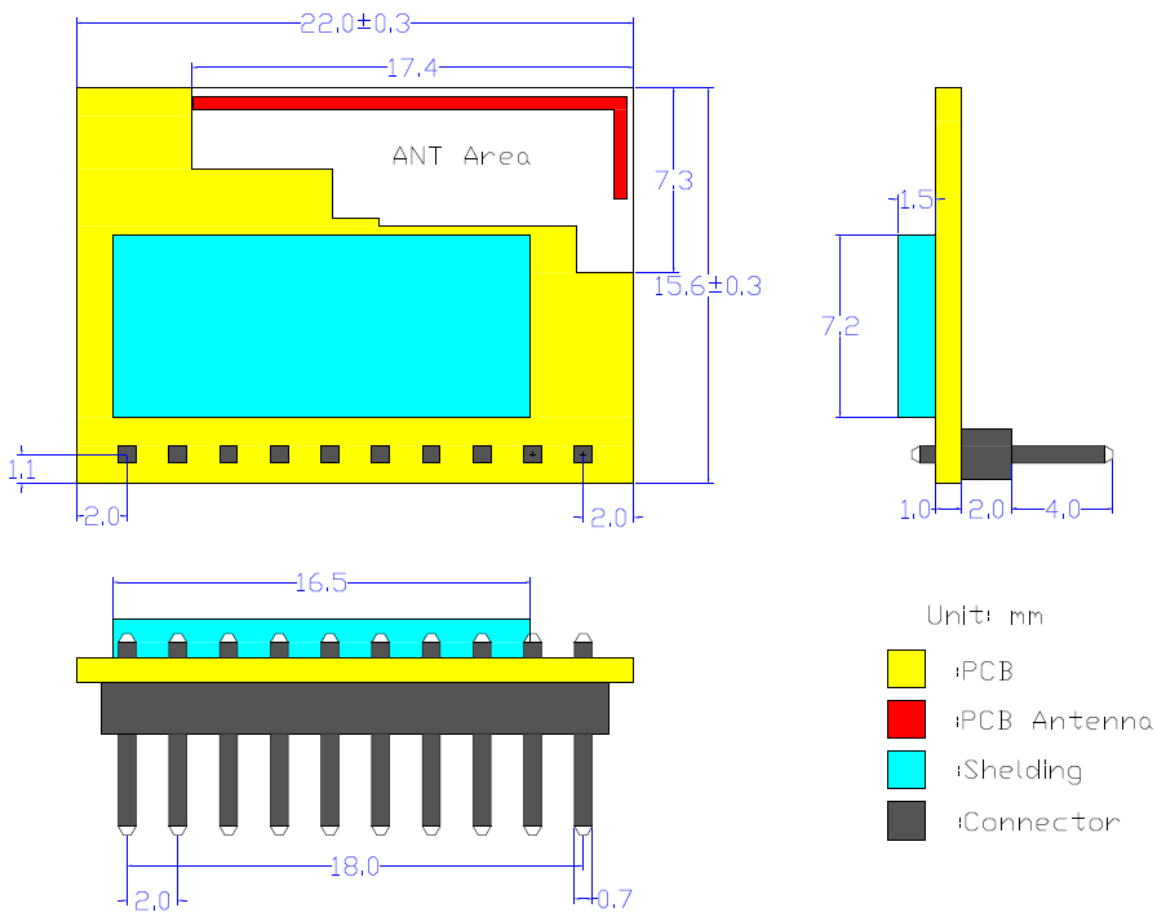

Figure 16. HF-LPT130B Mechanical Dimension

1.2.11. HF-LPT330 Mechanical Size

HF-LPT330 modules physical size (Unit: mm) as follows:

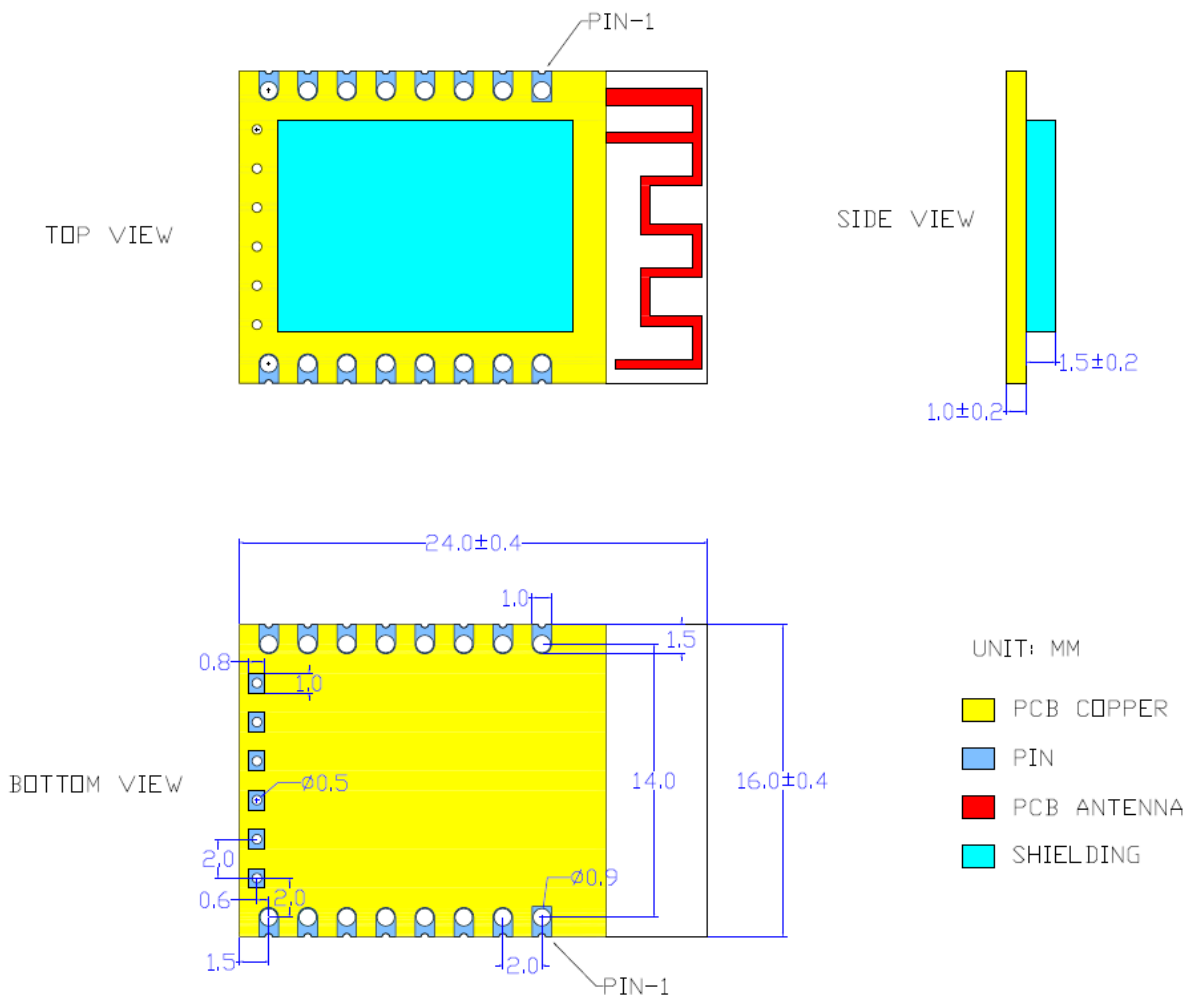

Figure 17. HF-LPT330 Mechanical Dimension

1.2.12. HF-LPB135 Mechanical Size

HF-LPB135 modules physical size (Unit: mm) as follows:

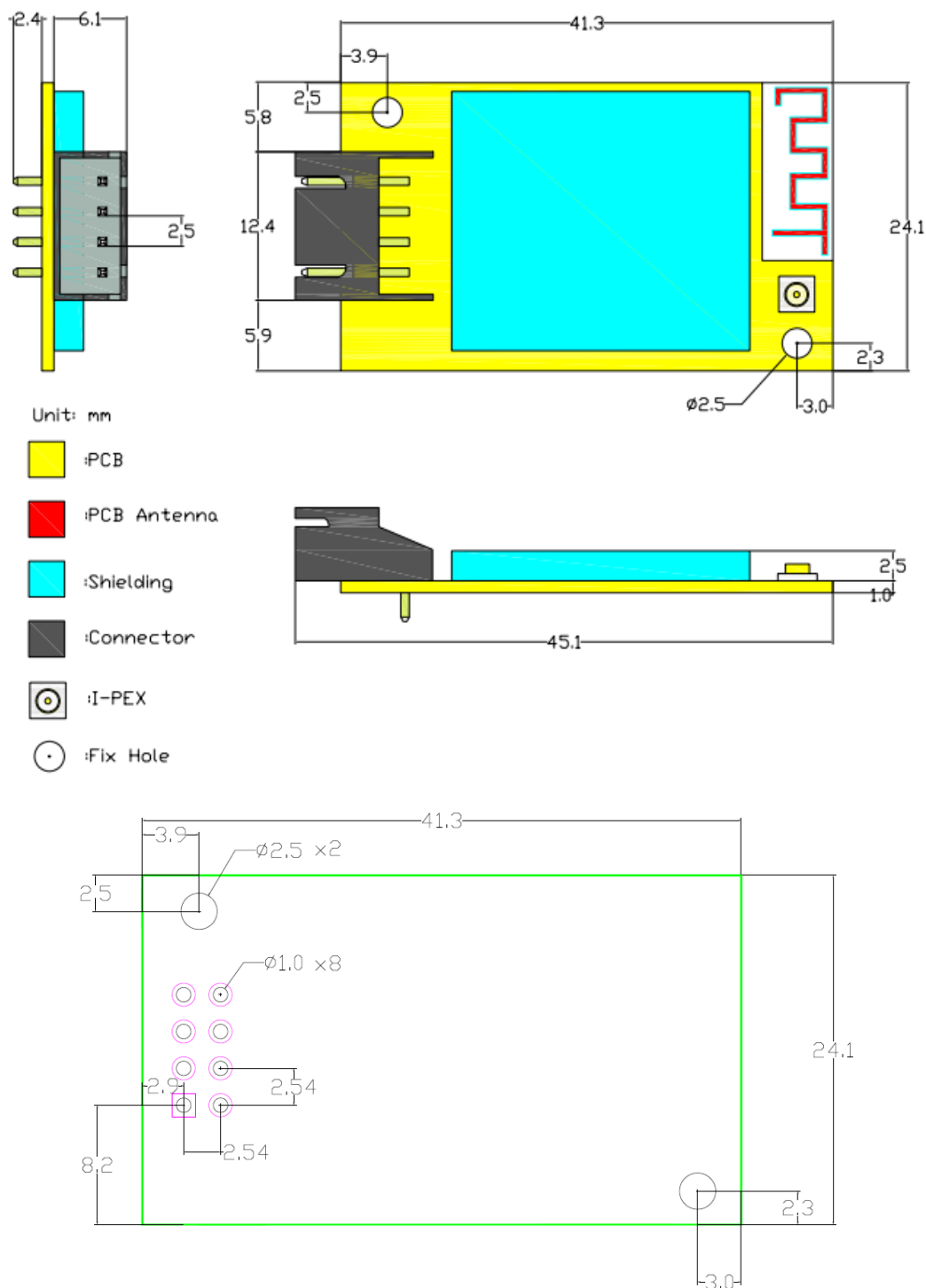

Figure 18. HF-LPB135 Mechanical Dimension

1.2.13. HF-LPB130 On-board PCB Antenna

HF-LPB130 module support internal on-board PCB antenna option. When customer select internal antenna, you shall comply with following antenna design rules and module location suggestions:

- For customer PCB, RED color region (8.3x18.4mm) can't put componet or paste GND net;
- Antenna must away from metal or high components at least 10mm;
- Antenna can't be shielded by any metal enclosure;

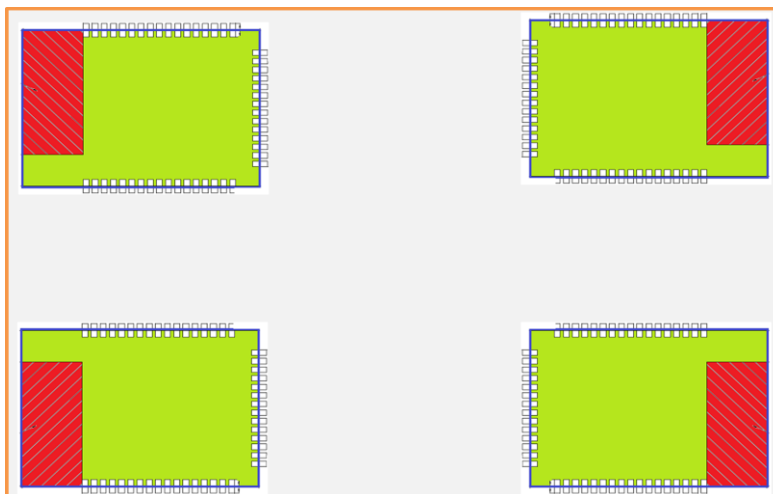

Figure 19. Suggested Module Placement Region

High-Flying suggest module better locate in following region at customer board, which to reduce the effect to antenna and wireless signal, and better consult High-Flying technical people when you structure your module placement and PCB layout.

1.2.14. HF-LPT230/HF-LPT330 On-board Chip Antenna

HF-LPT230/HF-LPT330 module support internal on-board chip antenna option. When customer select internal antenna, you shall comply with following antenna design rules and module location suggestions:

- For customer PCB, RED color region (HF-LPT230:5x13.5mm, HF-LPT330 6.2x12mm) can't put componet or paste GND net;
- Antenna must away from metal or high components at least 10mm;
- Antenna can't be shielded by any meal enclosure; All cover, include plastic, shall away from antenna at least 10mm;

High-Flying suggest module better locate in following region at customer board, which to reduce the effect to antenna and wireless signal, and better consult High-Flying technical people when you structure your module placement and PCB layout.

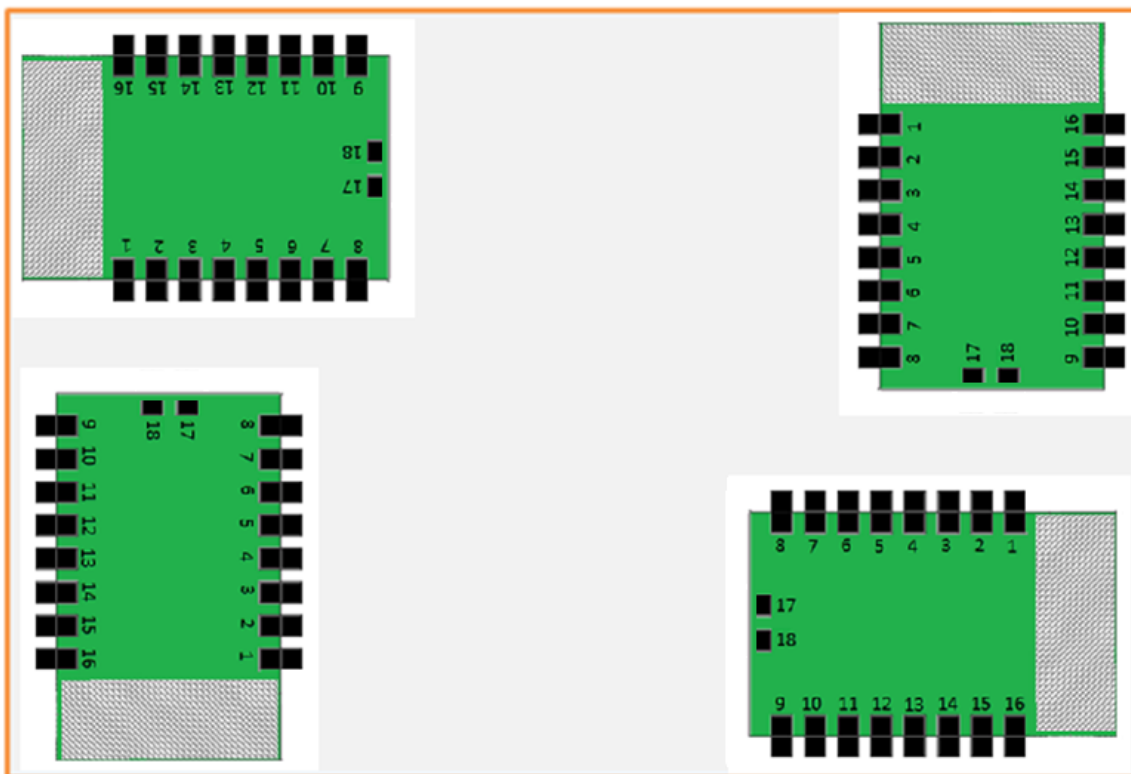

Figure 20. Suggested Module Placement Region

1.2.15. HF-LPT130A&B On-board Chip Antenna

HF-LPT130A&B module support internal copper line antenna option. When customer select internal antenna, you shall comply with following antenna design rules and module location suggestions:

- For customer PCB, RED color region (copper line antenna area) can't put componet or paste GND net;
- Antenna must away from metal or high components at least 10mm;
- Antenna can't be shieldedby any meal enclosure; All cover, include plastic, shall away from antenna at least 10mm;

High-Flying suggest module better locate in following region at customer board, which to reduce the effect to antenna and wireless signal, and better consult High-Flying technical people when you structure your module placement and PCB layout.

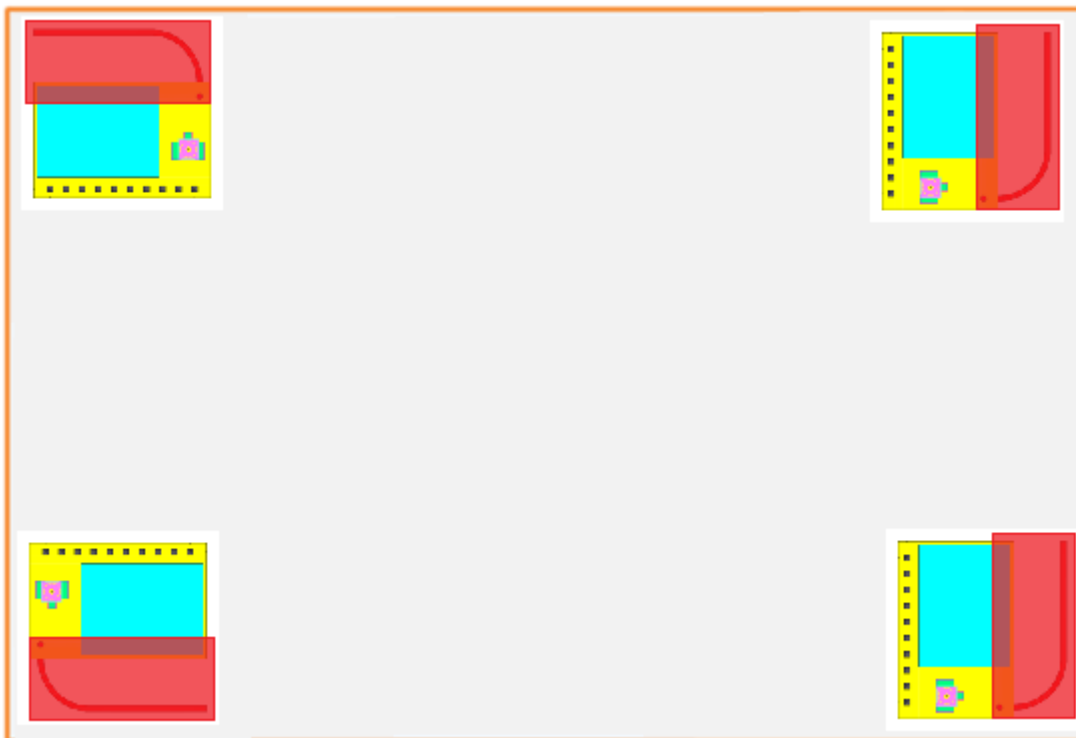

Figure 21. HF-LPT130A suggested Module Placement Region

1.2.16. External Antenna

HF-LPX30 series module supports external antenna(I-PEX) option for user dedicated application. If user select external antenna, HF-LPX30 series Wi-Fi modules must be connected to the 2.4G antenna according to IEEE 802.11b/g/n standards. We can provide external antenna if needed. Contact with our salesman.

The antenna parameters required as follows:

Table9. HF-LPX30 External Antenna Parameters

Item	Parameters
Frequency range	2.4~2.5GHz
Impedance	50 Ohm
VSWR	2 (Max)
Return Loss	-10dB (Max)
Connector Type	I-PEX or populate directly

1.2.17. Evaluation Kit

High-Flying provides the evaluation kit to promote user to familiar the product and develop the detailed application. The evaluation kit shown as below, user can connect to HF-LPX30 series module with the RS-232 UART, USB (Internal USB to UART convetor) or Wireless interface to configure the parameters, manage the module or do the some functional tests.

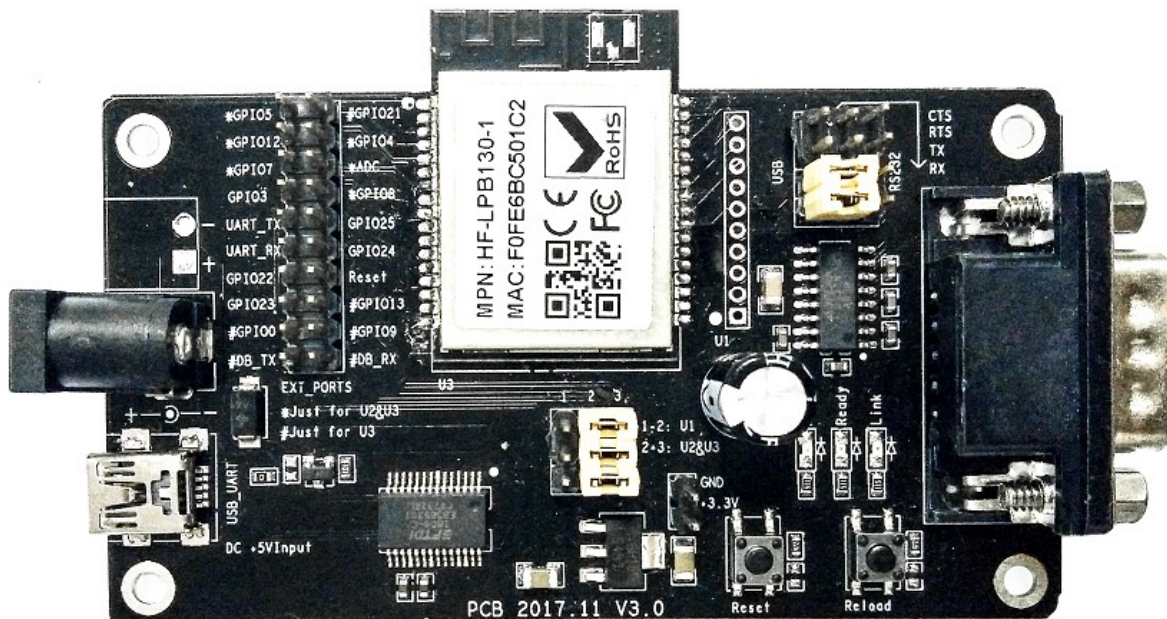

Figure 22. HF-LPB130 EVK

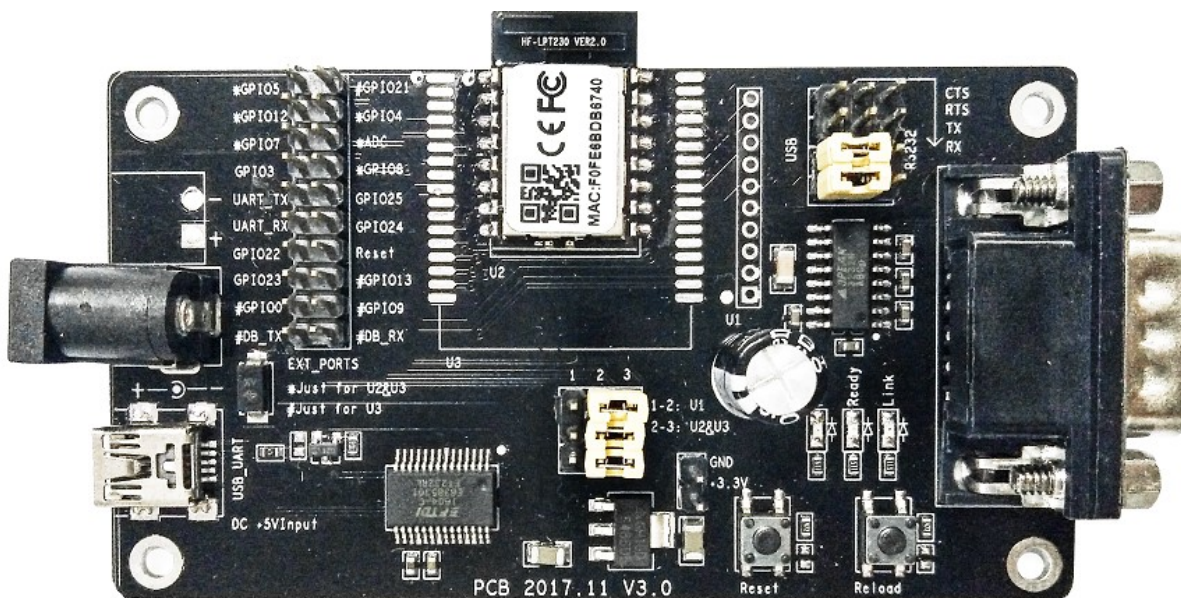

Figure 23. HF-LPT230 EVK

Notes: User need download USB to UART port driver from High-Flying web or contact with technical support people for more detail.

The external interface description for evaluation kit as follows:

Table10. HF-LPX30 Evaluation Kit Interface Description

Function	Name	Description
External Interface	RS232	Main data/command RS-232 interface, this interface maximum baud rate is 460800. Can not be used for debug UART log(It need 921600)
	USB	USB to UART interface, can be used for debug UART log

	DC5V	DC jack for power in, 5~9V input.
LED	Power	Power LED
	Ready	nReady LED
	Link	nLink LED
Button	nReload	Smartlink and Restore factory default configuration. See more for PIN Definition

1.2.18. Order Information

Base on customer detailed requirement, HF-LPX30 series modules provide different variants and physical type for detailed application.

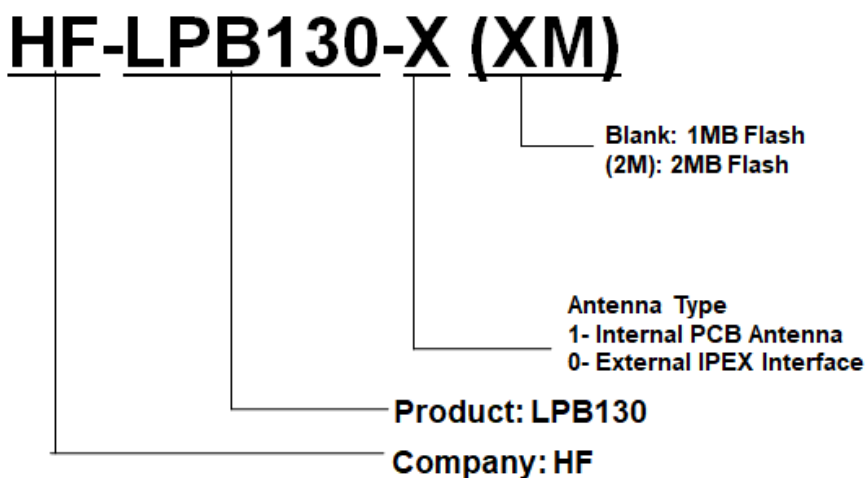

Figure 24. HF-LPB130 Order Information

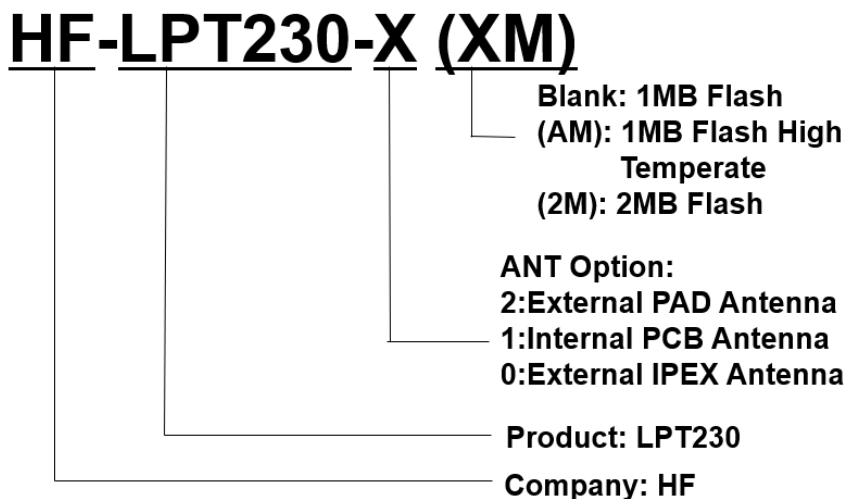

Figure 25. HF-LPT230 Order Information

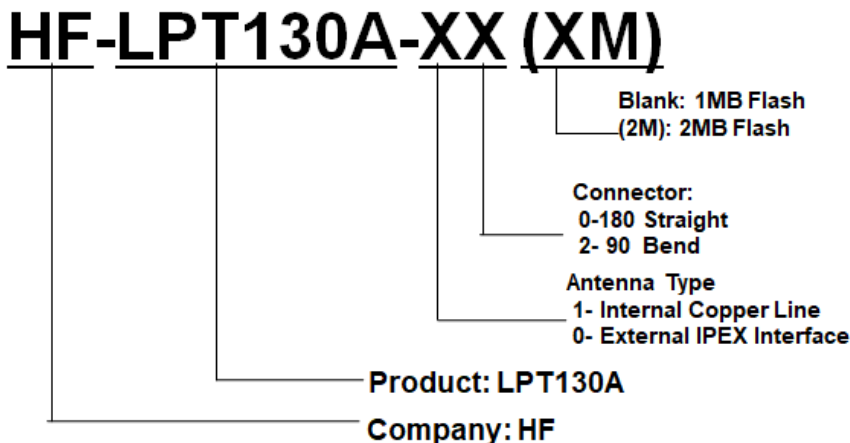

Figure 26. HF-LPT130A Order Information

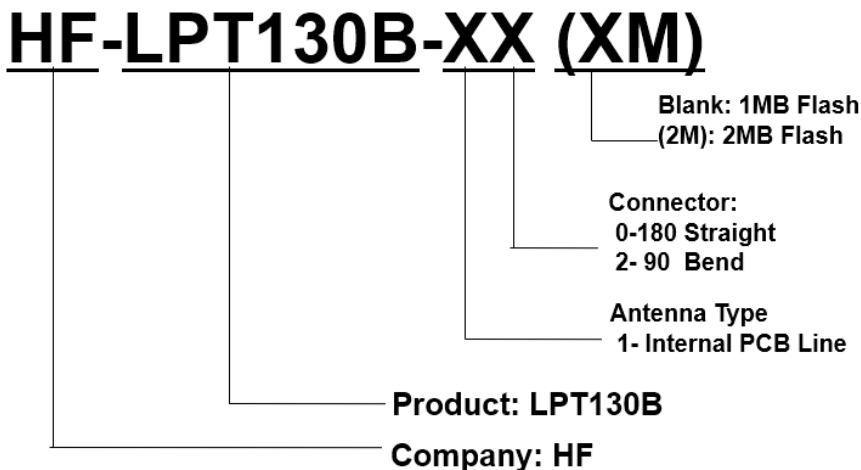

Figure 27. HF-LPT130B Order Information

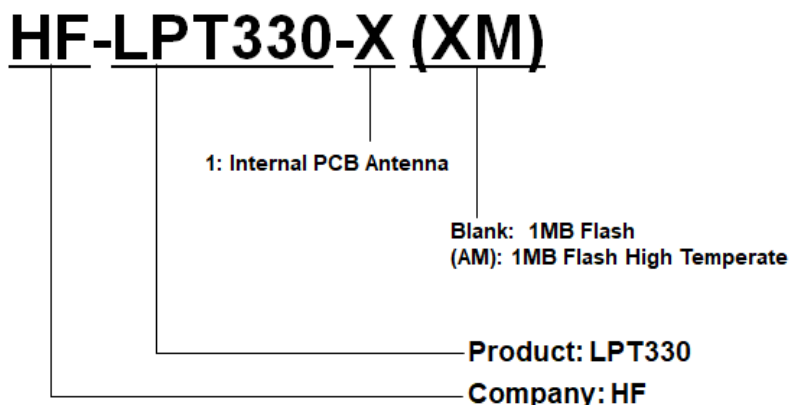

Figure 28. HF-LPT330 Order Information

HF-LPB135-XX (XM)

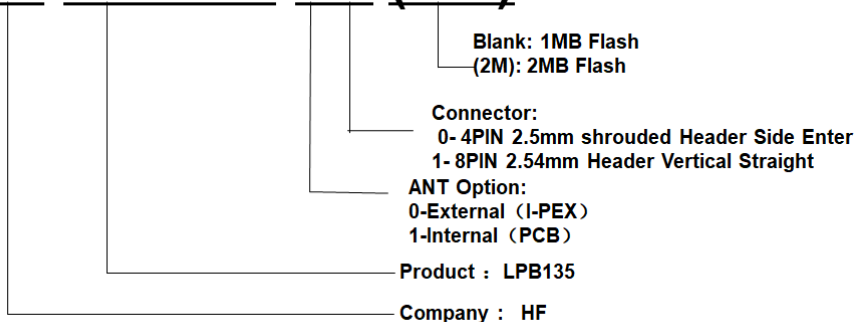

Figure 29. HF-LPB135 Order Information

1.2.19. Hardware Typical Application

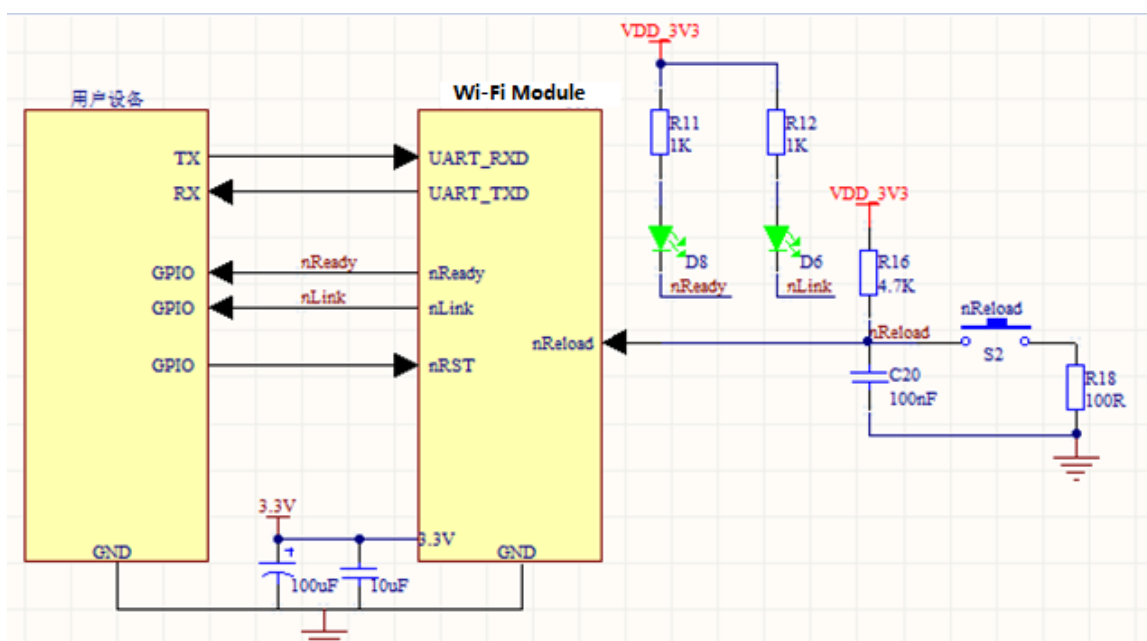

Figure 30. HF-LPX30 Hardware Typical Application

Notes:

nReset- Module hardware reset signal. Input. Logics “0” effective.
There is pull-up resistor internal and no external pull-up required. When module power up or some issue happened, MCU need assert nRST signal “0” at least 10ms, then set” 1” to keep module fully reset.

nLink- Module WIFI connection status indication. Output.
(This pin is recommend to connect to LED, indicate status when the module in wireless upgrade mode)

When module connects to AP (AP associated), this pin will output “0”. This signal used to judge if module already at WiFi connection status. There is pull-up resistor internal and no external pull-up required. If nLink function not required, can leave this pin open.

nReady- Module boot up ready signal. Output. Logics “0” effective.

The module will output “0” after normal boot up. This signal used to judge if module finish boot up and ready for application or working at normal mode. If nReady function not required, can leave this pin open.

nReload- Module restore to factory default configuration. Input. Logics “0” effective.

(This pin is recommend to connect to button, is used to enter wireless upgrade mode)

User can de-assert nReload signal “0” more than 4s through button or MCU pin, then release, module will restore to factory default configuration and re-start boot up process.. If nReload function not required, can leave this pin open.

UART0_TXD/RXD- UART port data transmit and receive signal.

2. FUNCTIONAL DESCRIPTION

2.1. Wireless Networking

HF-LPX30 module can be configured as both wireless STA and AP base on network type. Logically there are two interfaces in HF-LPX30. One is for STA, and another is for AP. When HF-LPX30 works as AP, other STA equipments are able to connect to HF-LPX30 module directly. Wireless Networking with HF-LPX30 is very flexible.

Notes:

AP: that is the wireless Access Point, the founder of a wireless network and the centre of the network nodes. The wireless router we use at home or in office may be an AP.

STA: short for Station, each terminal connects to a wireless network (such as laptops, PDA and other networking devices) can be called with a STA device.

2.1.1. Basic Wireless Network Based On AP

Infrastructure: it's also called basic network. It built by AP and many STAs which join in. The characters of network of this type are that AP is the centre, and all communication between STAs is transmitted through the AP. The figure following shows such type of networking.

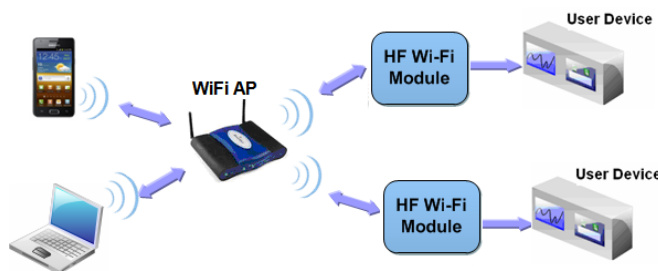

Figure 31. HF-LPX30 Basic Wireless Network Structure

2.1.2. Wireless Network Based On STA

HF-LPX30 module support STA network mode.

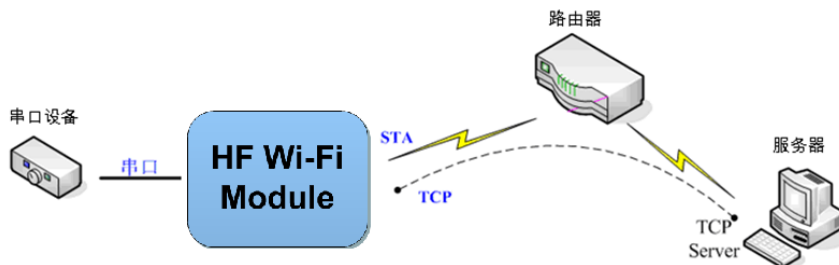

Figure 32. HF-LPX30 STA Network Structure

2.2. Work Mode : Transparent Transmission Mode

HF-LPX30 module support serial interface transparent transmission mode. The benefit of this mode is achieves a plug and play serial data port, and reduces user complexity furthest. In this mode, user should only configure the necessary parameters. After power on, module can automatically connect to the default wireless network and server.

As in this mode, the module's serial port always work in the transparent transmission mode, so users only need to think of it as a virtual serial cable, and send and receive data as using a simple serial. In other words, the serial cable of users' original serial devices is directly replaced with the module; user devices can be easy for wireless data transmission without any changes.

The transparent transmission mode can fully compatible with user's original software platform and reduce the software development effort for integrate wireless data transmission.

The parameters which need to configure include:

- **Wireless Network Parameters**
 - Wireless Network Name (SSID)
 - Security Mode
 - Encryption Key
- **TCP/UDP Linking Parameters**
 - Protocol Type
 - Link Type (Server or Client)
 - Target Port ID Number
 - Target Port IP Address
- **Serial Port Parameters**
 - Baud Rate
 - Data Bit
 - Parity (Check) Bit
 - Stop Bit
 - Hardware Flow Control

2.3. Registration Package Function

Under the transparent transmission mode, the registration package function can be enabled. When the connection is established (TCP only) or the serial port data is received, the content of the registration package is automatically added to the server, and the content of the registration package can be used with the signal strength, MAC, etc. Details refer to AT+NREGDT command.

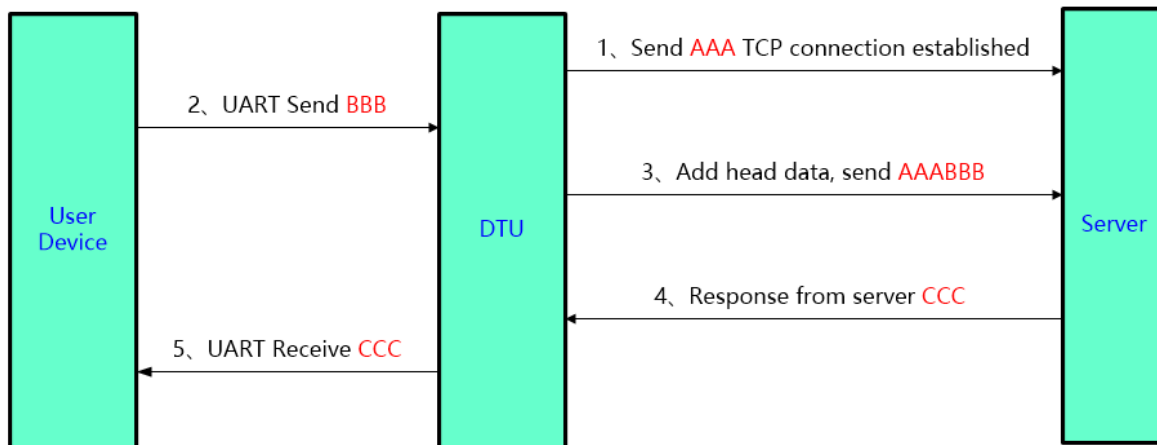

Figure 33. Transparent Transmission Mode Registration Packet Function Transmission

The example of registration package function is as follows: The following commands respectively enable the registration function of SOCKA, set the content of the registration package to MAC+ ABCD, enable the registration package when establishing connection and sending data.

```

AT+NREGEN=A, on
+ok

AT+NREGDT=A, %MACABCD
+ok

AT+NREGSND=A, both
+ok
    
```

Figure 34. Transparent Transmission Mode Registration Package Function Example

2.4. Heartbeat Package Function

In the transparent transmission mode, the heartbeat packet function can be enabled, and the module periodically sends heartbeat data to the server or the serial port. For details, refer to the AT+HEART command.

The user can also choose to send a heartbeat packet to the serial device.

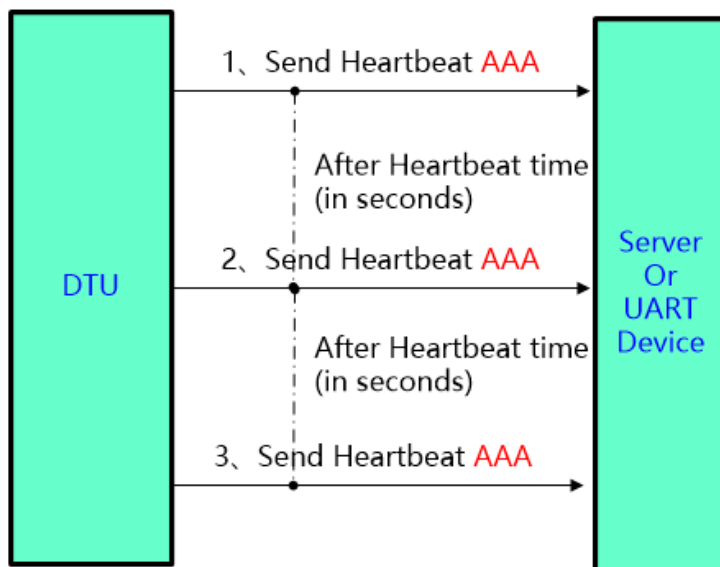

Figure 35. Transparent Transmission Mode Heartbeat Packet Function Transmission

2.5. SOCKA HTTP Mode

SOCKA channel support HTTP protocol. Under this mode, the user's terminal device can send request data to the specified HTTP server through this module. The module will receive the data from the HTTP server, parses the data and sends the results to the serial device. The user does not need to pay attention to the data conversion process between the serial port data and the network data packet, and the data request of the serial port device to the HTTP server can be realized by simple parameter setting.

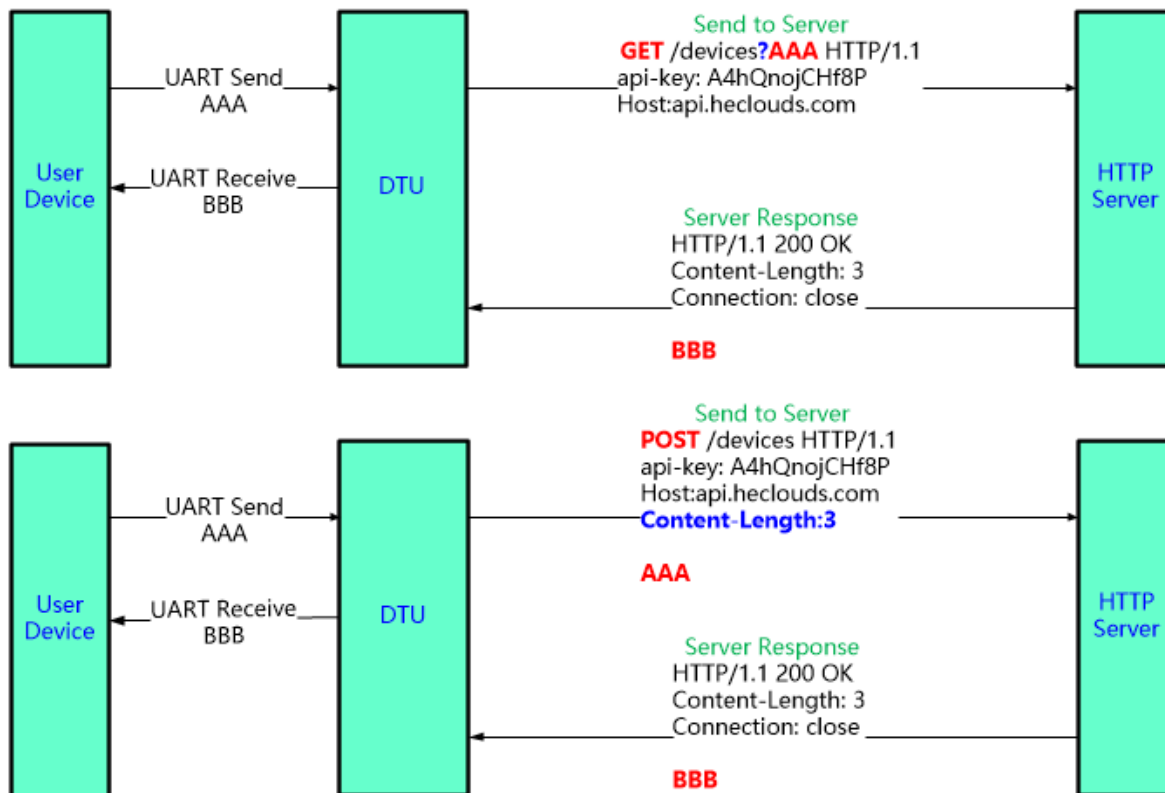

Figure 36. HTTP Mode Transmission

For GET request, the received UART packet AAA will put after the HTTP path (auto add “?” between path and parameters), for POST request, packet is put in the content (auto add Content-Length header information).

Product will send the below data to HTTP Server when UART receive “pppp” data for GET request.

```
GET /1111?pppp HTTP/1.1
Host: 192.168.83.107
```

Product will output “DDDDD” when get response from the HTTP server.

```
HTTP/1.1 200 OK
Server: nginx
Content-Length: 5
```

```
DDDDD
```

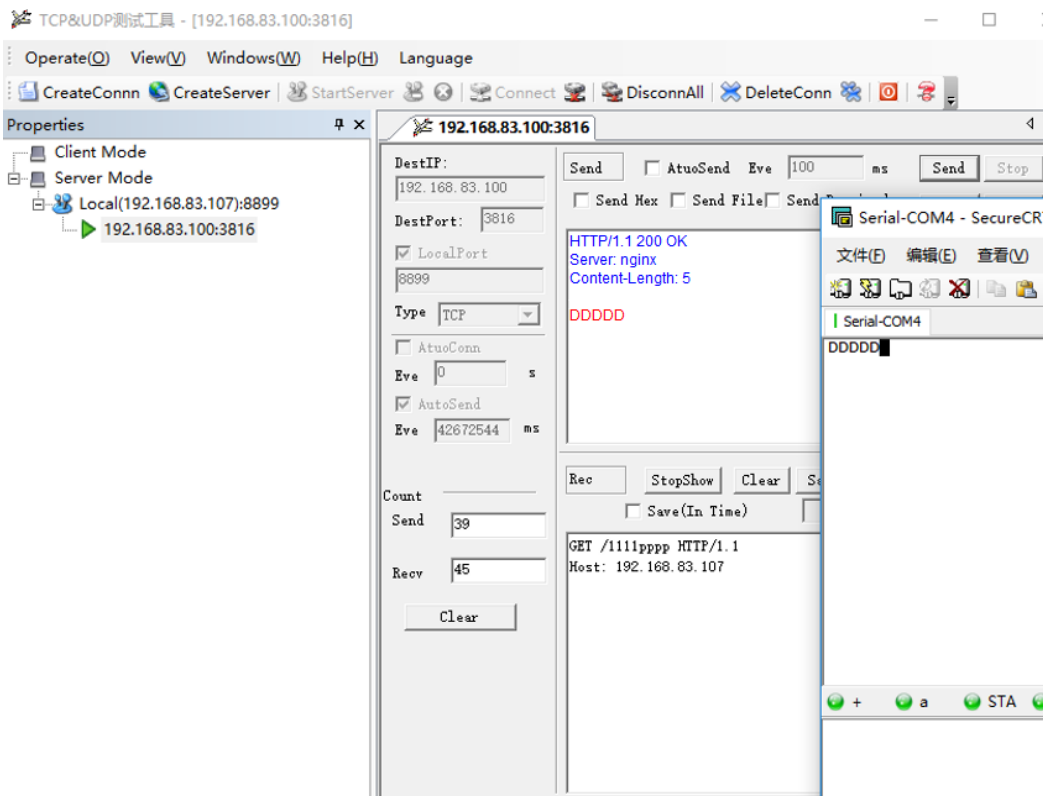

Figure 37. HTTP GET Request Example

Product will send the below data to HTTP Server when UART receive “pppp” data for POST request.

POST /1111 HTTP/1.1
 Host: 192.168.83.107
 Content-Length:4

pppp

Product will output “DDDD” when get response from the HTTP server.

HTTP/1.1 200 OK
 Content-Length: 4
 Connection: close

DDDD

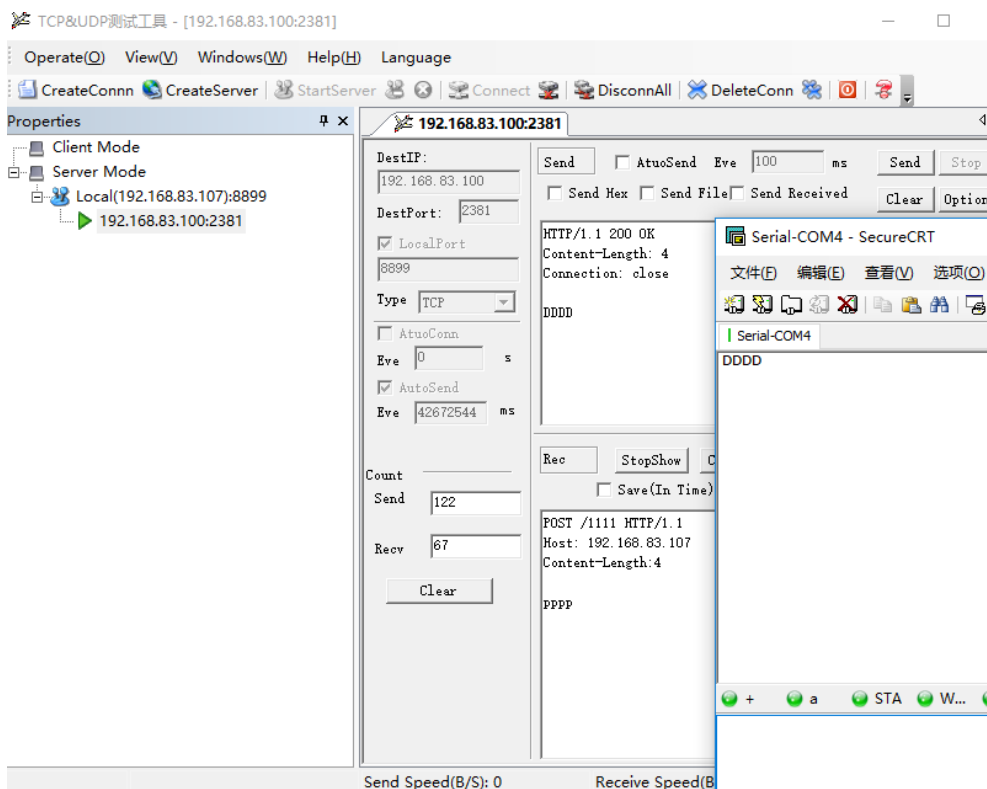

Figure 38. HTTP POST Request Example

The HTTP AT command example is as following.

- AT+NETP=HTTP, 8899,192.168.83.106,8899
- AT+HTPTP=POST
- AT+HTPURL=/abcde,1.1
- AT+HTPHEAD=Host:192.168.83.106:8899<CRLF><CRLF>Connection: keep-alive<CRLF><CRLF>

If need put received packet to URL in POST request ilke GETrequest, config it with AT+HTPTP command.

2.6. SOCKA MQTT Mode

Device support MQTT Client send data to MQTT Server.

More MQTT Case refer to following link.

<http://www.hi-flying.com/download-center-1/application-notes-1/download-item-industry-products-application-manual-20180415>

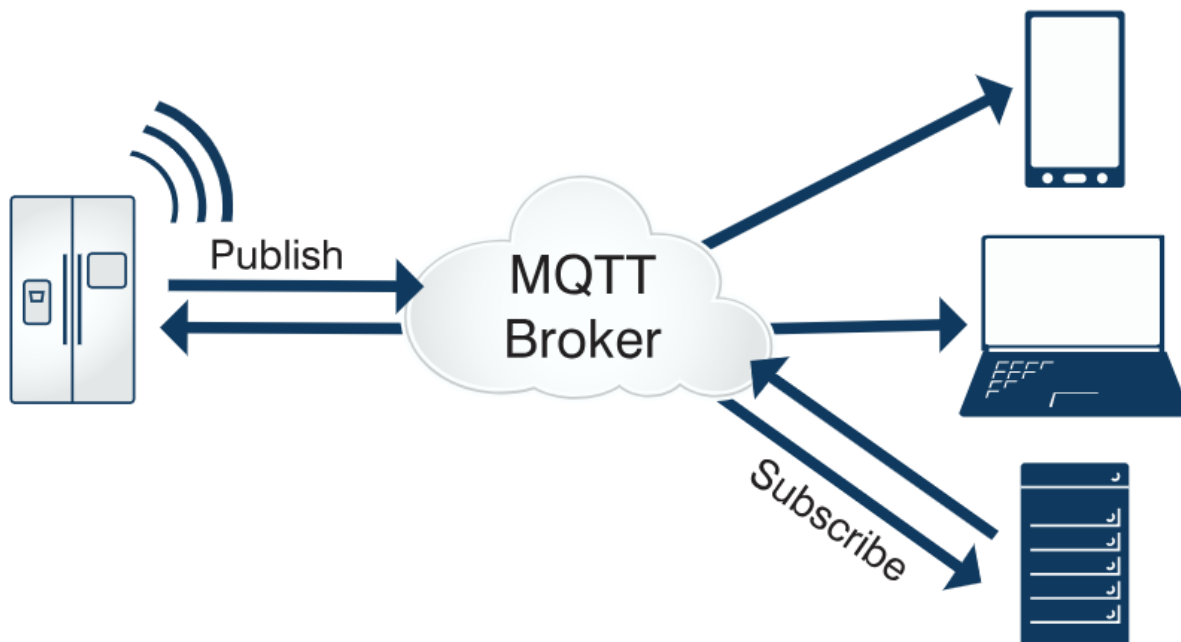

Figure 39. MQTT Concept

Setting example

- AT+NETP=MQTT,1883,47.99.135.189
- AT+MQLOGIN=admin,public
- AT+MQID=F0FE6BEF8702
- AT+MQTOPIC=deviceid/up,deviceid/down
- AT+MQTOPIC=%MAC/up,%MAC/down
- AT+HEART=A,120,abcde

2.7. UART Frame Scheme

Support UART free-frame function. If user select open this function, module will check the intervals between any two bytes when receiving UART data. If this interval time exceeds defined value (50ms default), module will think it as the end of one frame and transfer this free-frame to WiFi port, or will receive UART data until 1000 bytes, then transfer 1000 bytes frame to WiFi port.

2.8. Encryption

Encryption is a method of scrambling a message that makes it unreadable to unwanted parties, adding a degree of secure communications. There are different protocols for providing encryption, and the HF-LPX30 module supports following:

- ◆ WEP
- ◆ WPA-PSK/TKIP
- ◆ WPA-PSK/AES
- ◆ WPA2-PSK/TKIP
- ◆ WPA2-PSK/AES

2.9. Parameters Configuration

HF-LPX30 module supports two methods to configuration parameters: **AT+instruction set**.
 AT+instruction set configuration means user configure parameters through serial interface command.
 Refer to “AT+instruction set” chapter for more detail.

2.10. Firmware Update

HF-LPX30 module supports multiple upgrade methods:

- UART upgrade
- Local Network upgrade

2.11. SOCKB Function

HF-LPX30 support double socket communication, the SOCKB function is disabled by default.

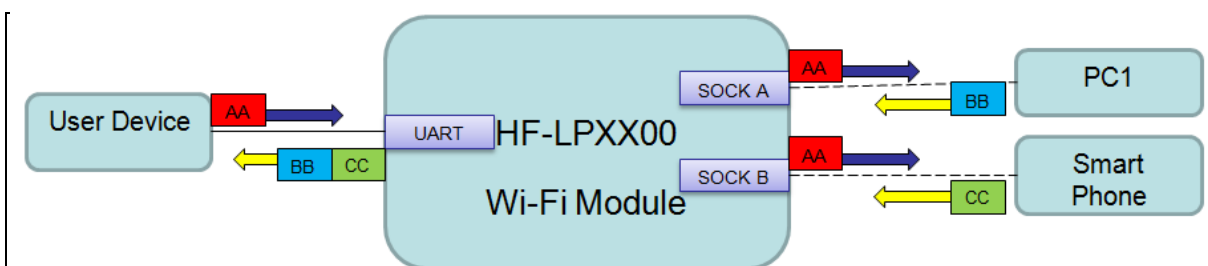
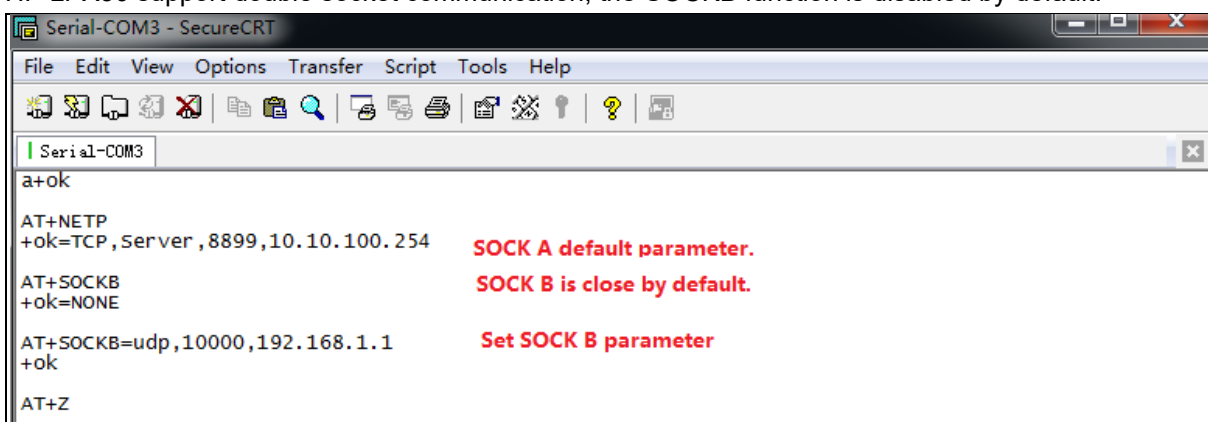

Figure 40. SOCKB function demo

Use AT+NETPIDEN, AT+NETPID command to distinguish the data packet.

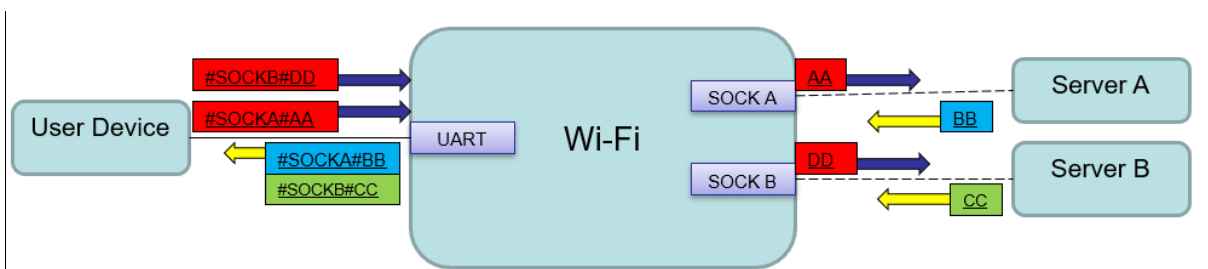

Figure 41. Two Socket Data Separation

2.12. Multi-TCP Link Connection

When HF-LPX30 module SOCK A configured as TCP Server, it supports Multi-TCP link connection, and maximum 5 TCP clients permitted to connect to HF-LPX30 module. User can realize multi-TCP link connection at each work mode.

Multi-TCP link connection will work as following structure:

Upstream: All dates from different TCP connection or client will be transmitted to the serial port as a sequence.

Downstream: All data from serial port (user) will be replicate and broadcast to every TCP connection or client.

Detailed multi-TCP link data transmission structure as following figure:

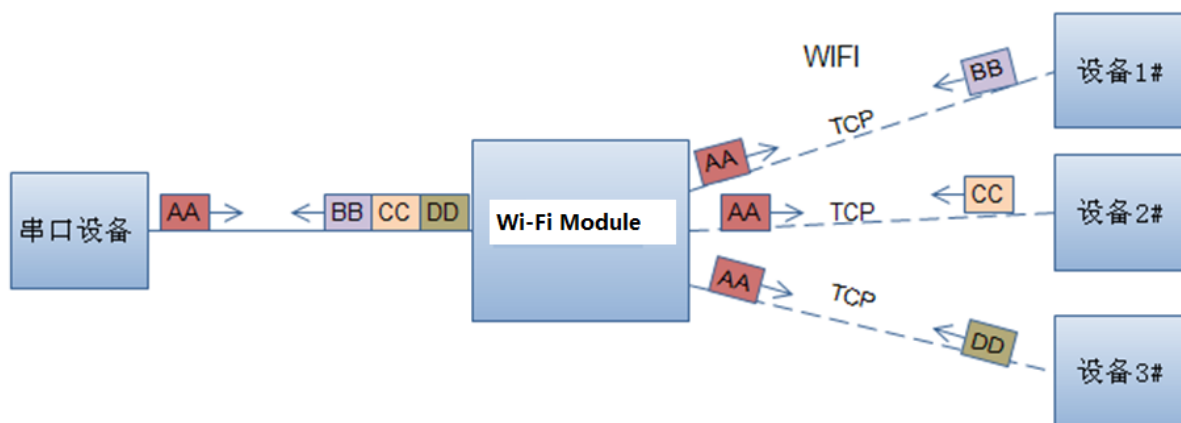

Figure 42. Multi-TCP Link Data Transmission Structure

2.13. Event Notification Function

AT+EVENT=on to enable event notification function, if module working status changed, it will output UART data initiatively.

Table11. Event Notification

Event Notification Data	Condition
+EVENT=SOCKA_ON	SOCKA connection success (TCP Client/Server, HTTP, MQTT)
+EVENT=SOCKA_OFF	SOCKA connection break (TCP Client/Server, HTTP, MQTT)
+EVENT=SOCKB_ON	SOCKB connection success (TCP Client)
+EVENT=SOCKB_OFF	SOCKB connection break (TCP Client)
+EVENT=CON_ON	STA Connect to router success
+EVENT=CON_OFF	STA Disconnect with router
+EVENT=DHCP_OK	STA DHCP got IP

3. OPERATION GUIDELINE

3.1. Configuration

When first use HF-LPX30 series modules, user may need some configuration. User can connect to HF-LPX30 module’s wireless interface with following default setting information and configure the module through laptop.

Table12. HF-LPX30 Web Access Default Setting

Parameters	Default Setting
SSID	HF-LPB130 HF-LPT230 HF-LPT130A HF-LPT130B HF-LPT330
IP Address	10.10.100.254
Subnet Mask	255.255.255.0
Account	admin
Password	admin

3.1.1. Open Web Management Interface

There is internal webpage and external webpage in modules. The external webpage is for web management. The internal webpage is only for upgrading. 1MB Flash external webpage is different from 2MB/4MB Flash version, but the internal webpage is the same.

- Step 1: Connect laptop to SSID “HF-LPT230” of HF-LPT230 module via wireless LAN card;
- Step 2: After wireless connection OK. Open Wen browser and access “<http://10.10.100.254>”;
- Step 3: Then input user name and password in the page as following and click “OK” button.



Figure 43. Open Web Management page

The 1MB Flash version has the simple config page while the 2MB/4MB Flash version has the full config page. 1MB Flash version webpage is as following(By default is Chinese language, upgrade via internal webpage to upgrade English language).

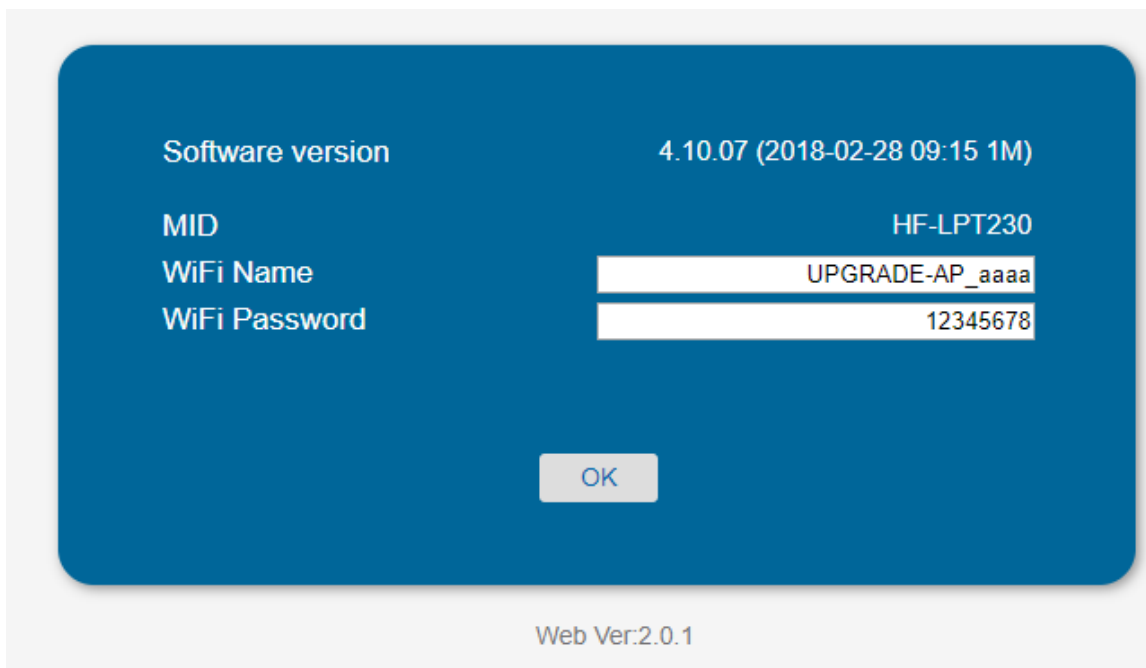

Figure 44. 1MB Flash Version webpage

The HF-LPX30 web management page support English and Chinese language. User can select language environment at the top right corner and click “Apply” button.

The main menu include nine pages: “System”, “Work Mode”, “STA Setting”, “AP Setting”, “Other Setting”, “Account”, “Upgrade SW”, “Restart”, “Restore”.

3.1.2. System Page

At this page, user can check current device’s important information and status such as: device ID (MID), software version, wireless work mode and related Wi-Fi parameters.

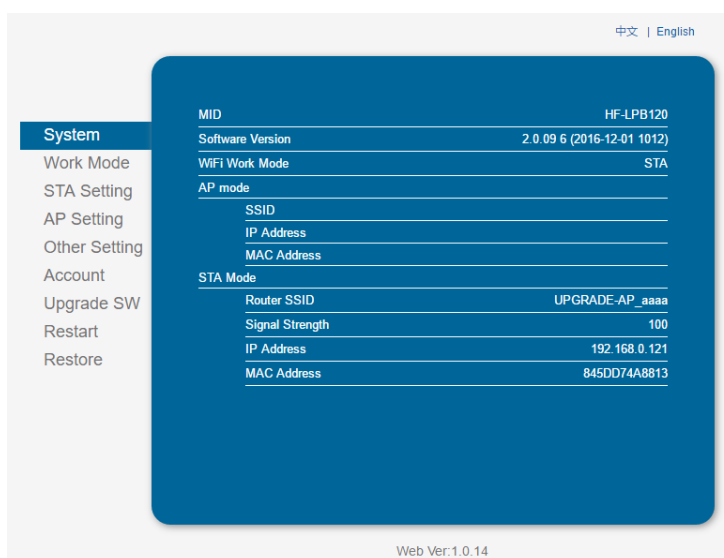

Figure 45. System Web Page

3.1.3. Work Mode Page

HF-LPX30 module can works at AP mode to simplify user's configuration, can also works at STA to connect remote server through AP router.

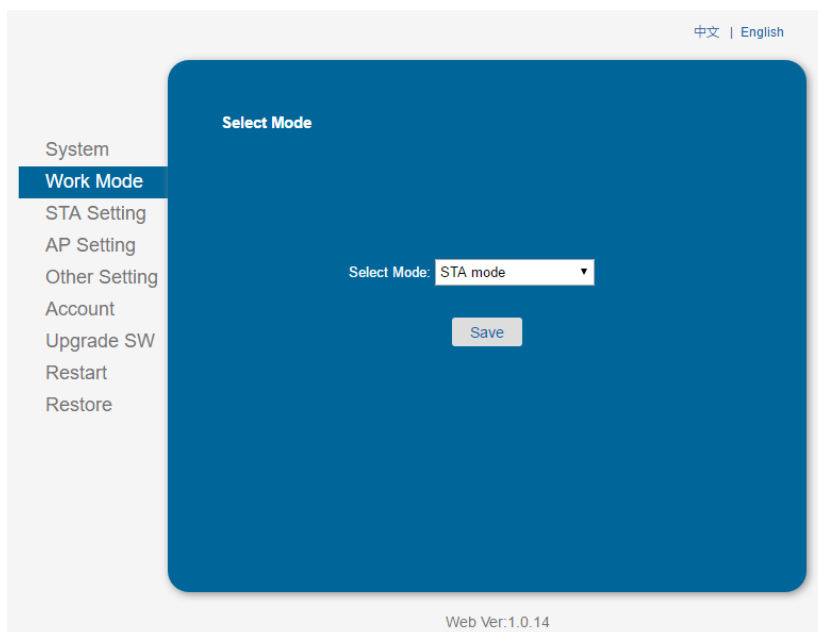

Figure 46. Work Mode Page

3.1.4. STA Setting Page

User can push "Scan" button to auto search Wi-Fi AP router nearby, and can connect with associate AP through some settings. Please note the encryption information input here must be fully same with Wi-Fi AP router's configuration, and then it can link with AP correctly.

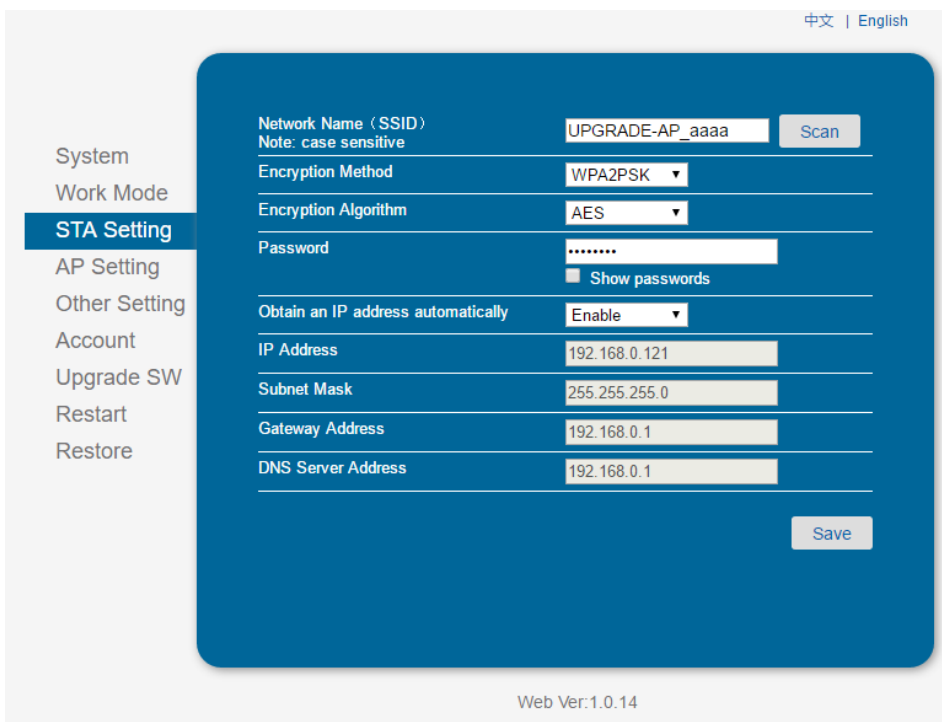

Figure 47. STA Setting Page

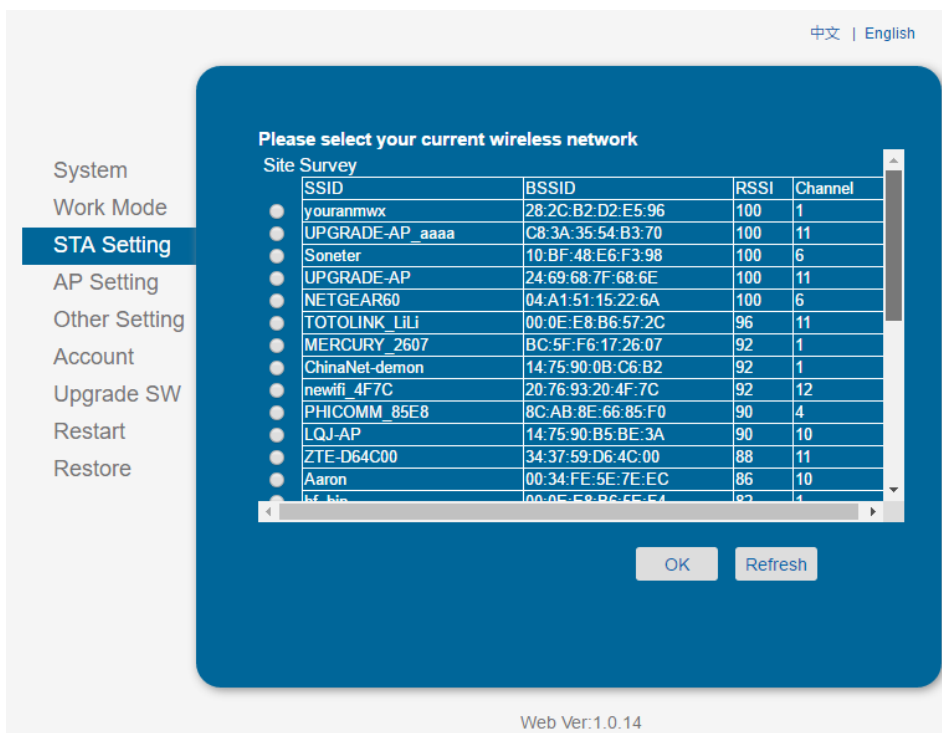

Figure 48. STA Scan Page

3.1.5. AP Setting Page

When user select module works at AP and AP+STA mode, then need setting this page and provide wireless and network parameters. Most of the system support DHCP to achieve IP address, so we suggest to “Enable” DHCP server in most applications.

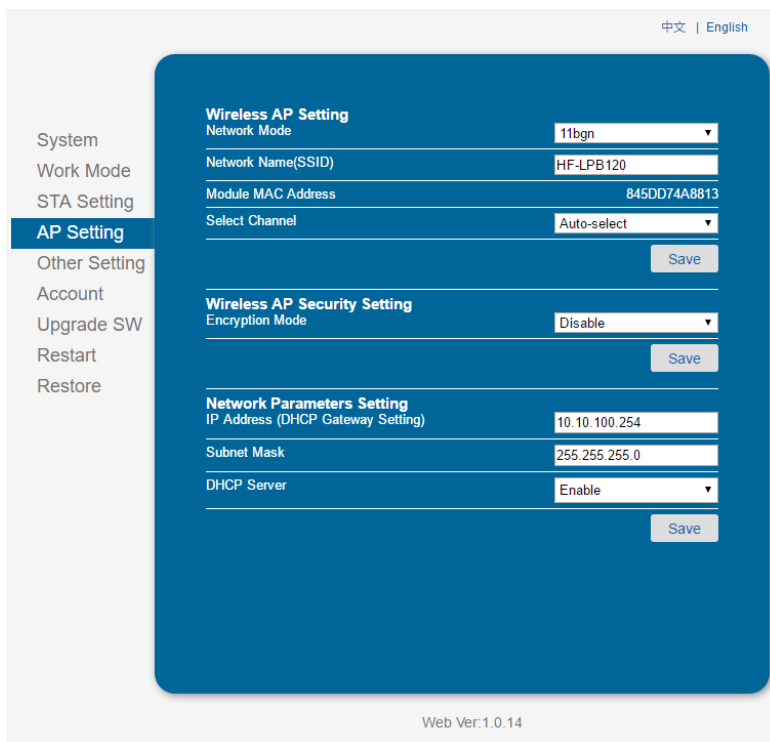

Figure 49. AP Setting Page

3.1.6. Other Setting Page

HF-LPX30 usually works at data transparent transmission mode. At this mode, the user device which connected with HF-LPX30 will connect and communicate with remote PC or server. At this page, user need setting serial port communication parameters and defines TCP related protocol parameters.

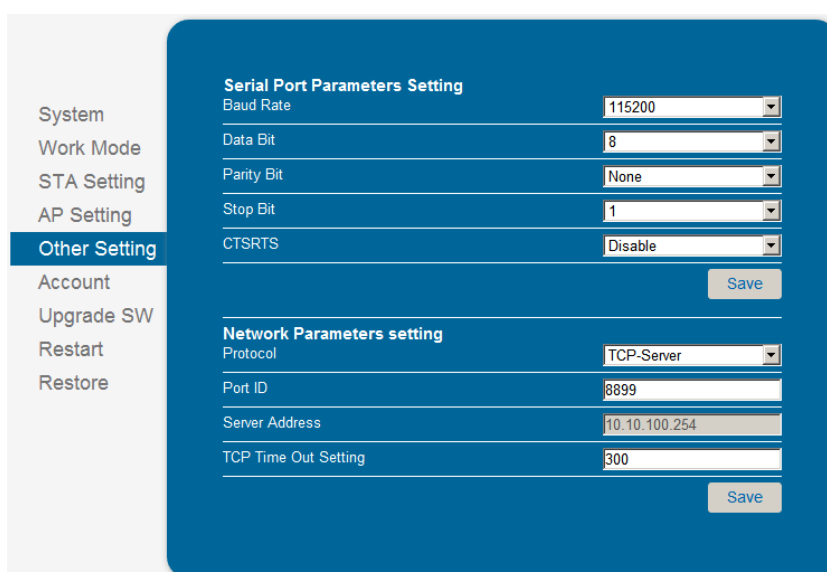

Figure 50. Other Setting Page

3.1.7. Account Management Page

This page set web server's user name and password.

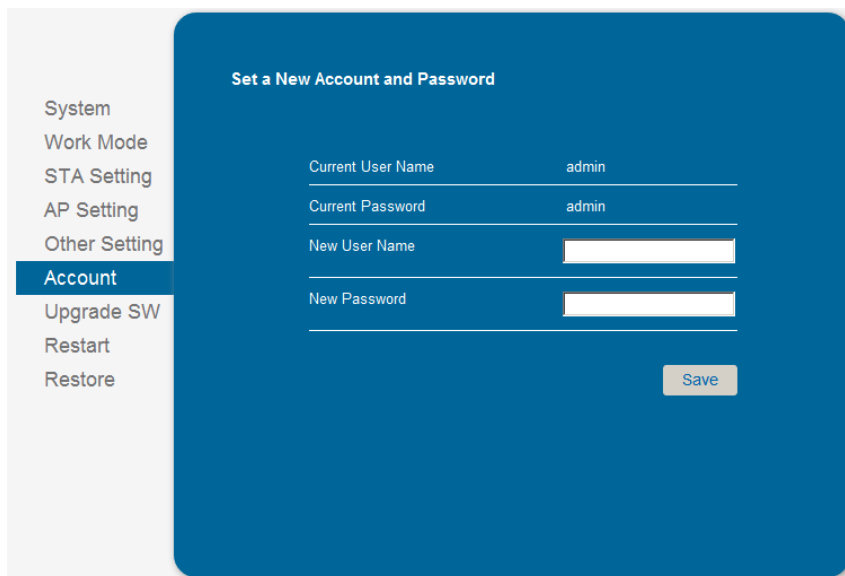

Figure 51. Account Page

3.1.8. Upgrade Software Page

User can upgrade new software (firmware) version through Wi-Fi. After upgrade success, need reboot it manually before new firmware valid.

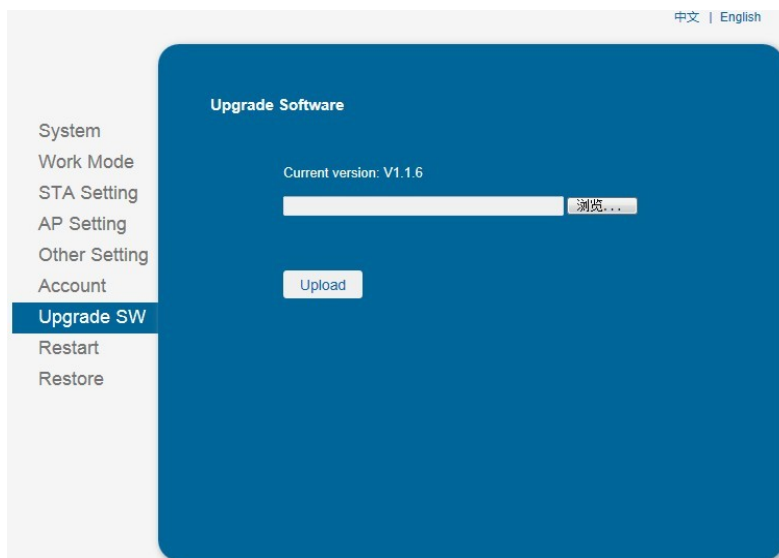

Figure 52. Upgrade SW page

3.1.9. Restart Page

Most of the setting and configuration can only effective after system restart. User shall restart after finish all setting.

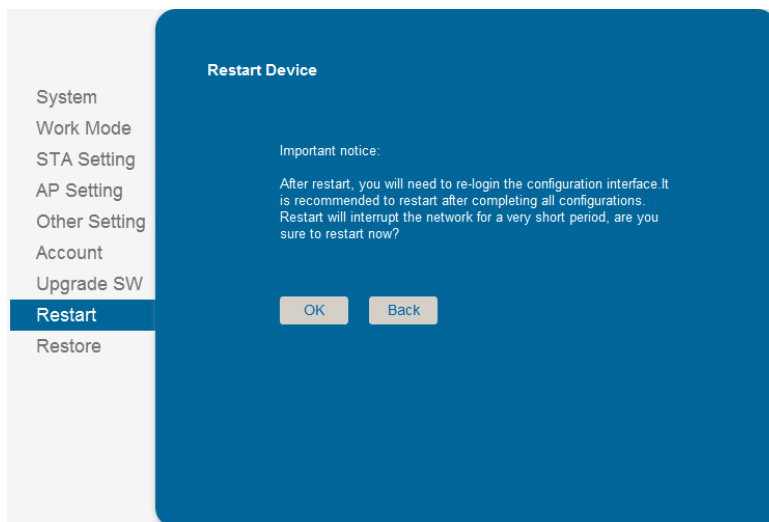

Figure 53. Restart Page

3.1.10. Restore Page

After module restore factory default setting, all user configuration profile will lose.

User can access <http://10.10.100.254> to set again, and user name and password is “admin”. HF-LPX30 will restore to AP mode for factory default setting.

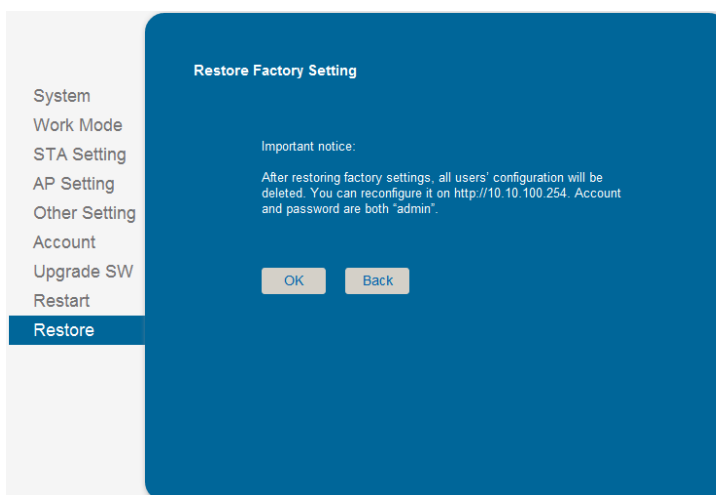

Figure 54. Restore Page

3.1.11. Internal Webpage

After wireless connection is OK. Open Wen browser and access “<http://10.10.100.254/iweb.html>”; It is for upgrading application and external webpage..

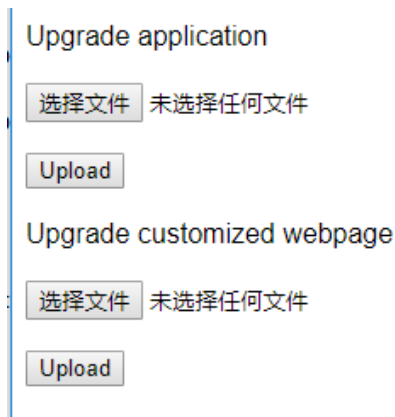

Figure 55. Internal Webpage

3.2. Usage Introduction

3.2.1. Software Debug Tools

High-Flying use two common software tools debugging and applying HF-LPX30 module. (User can also select other tools used to debug serial port).

- Serial Debugging Software: ComTools ComTools.exe
- Ethernet Debugging Software: TCPUDPDbg TCPUDPDbg.exe

3.2.2. Network Connection

User can select two methods to connect HF-LPX30 module base on dedicated application.

- **Use HF-LPX30 STA interface.** HF-LPX30 and debug PC2 connect to a wireless AP, another PC1 (or user device) connect to HF-LPX30 module with serial port:



Figure 56. STA Interface Debug Connection

- **Use HF-LPX30 AP interface.** Debug PC2 connect to HF-LPX30 through wireless connection, another PC1 (or user device) connect to HF-LPX30 module with serial port.



Figure 57. AP Interface Debug Connection

3.2.3. Default Parameter Setting

- Default SSID: HF-LPX30;

- Deault security mode: open,none;
- User UART parameter setting:115200,8,1,None;
- Default network parameter setting:TCP,Server,8899,10.10.100.254;
- Module IP address: dhcp,0.0.0.0,0.0.0.0,0.0.0.0;

3.2.4. Module Debug

PC1 open “CommTools” program, setting the same serial port parameters with HF-LPX30 module and open serial port connection.

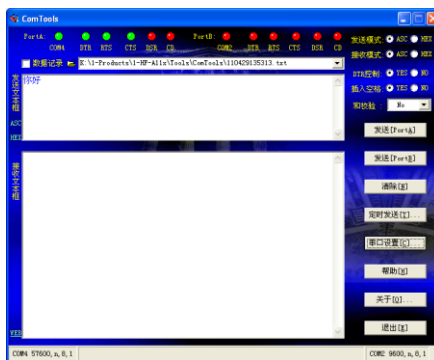

Figure 58. “CommTools” Serial Debug Tools

PC2 open “TCPUDPDbg” program, and create a new connection. If HF-LPX30 configured as Server mode, “TCPUDPDbg” Tools shall create “Client” mode connection. Or otherwise, create a “Server” mode connection.

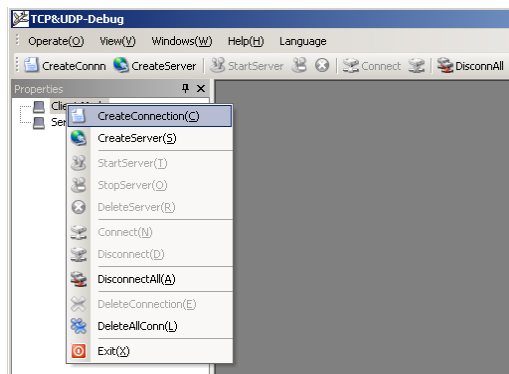

Figure 59. “TCPUDPDbg” Tools Create Connection

Then setting the TCP/UDP connection parameters. Default as following:

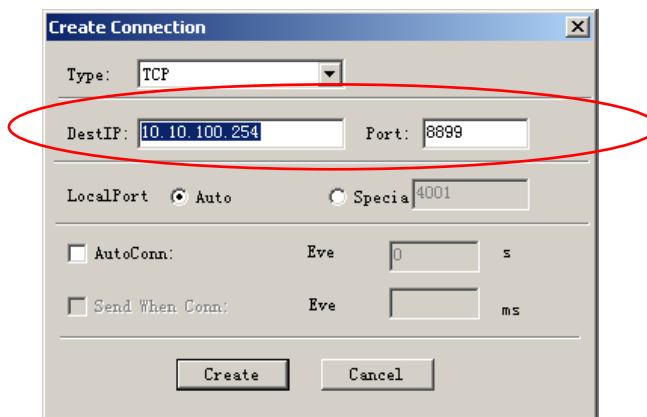

Figure 60. “TCPUDPDbg” Tools Setting

Then, click “Create” button to create a connection.

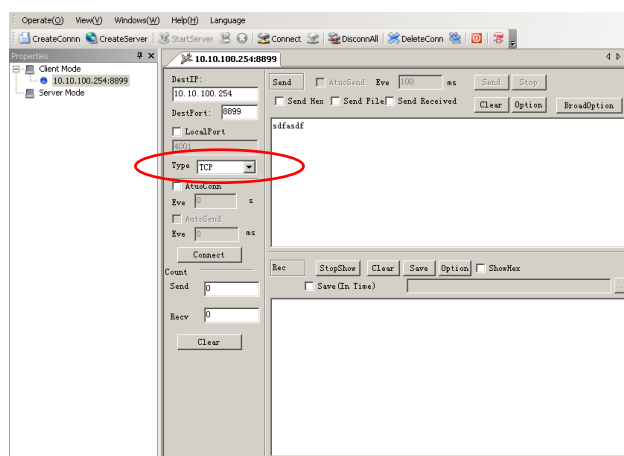

Figure 61. “TCPUDPDbg” Tools Connection

Now, in transparent transmission mode, data can be transferred from “CommTools” program to “TCPUDPDbg” program, or in reverse. You can see data in receiver side will keep same as in sender side.

3.3. Typical Application Examples

3.3.1. Wireless Control Application



Figure 62. Wireless Control Application

For this wireless control application, HF-LPX30 works as AP mode. Module’s serial port connects to user device. So, control agent (Smart phone for this example) can manage and control the user device through the wireless connection with HF-LPX30 module.

3.3.2. Remote Management Application

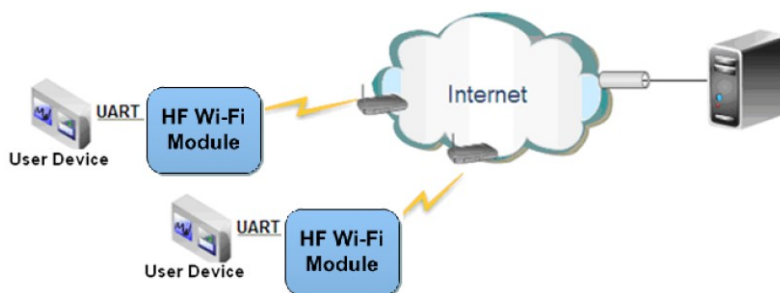

Figure 63. Remote Management Application

For this remote management application, HF-LPX30 works as STA mode and connects to Internet through wireless AP. Module configured as TCP Client and communicates with remote TCP server at Internet. Module’s serial port connects to user device.

So, user device’s data or sampling information can send to remote TCP server for storage or processing. Also remote TCP server can send command to control and manage the user device through the wireless network.

3.3.3. Transparent Serial Port Application

For this transparent serial port application, two HF-LPX30 modules connect as below figures to build up a transparent serial port connection. One HF-LPX30 works as AP mode, another HF-LPX30 works as STA mode. Make the STA device connects to AP.



Figure 64. Transparent Serial Port Application

4. AT+INSTRUCTION INTRODUCTION

4.1. Configuration Mode

When HF-LPX30 power up, it will default works as transparent transmission mode, then user can switch to configuration mode by serial port command. HF-LPX30 UART default parameters setting as below figure,

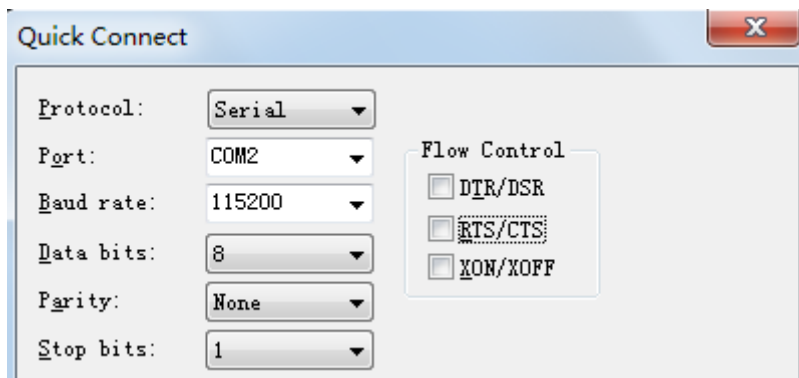

Figure 65. HF-LPX30 Default UART Port Parameters

In configuration mode, user can setting the module through AT+instruction set, which cover all web page setting function.

4.1.1. Switch to Configuration Mode

Two steps to finish switching from transparent transmission mode to configuration mode.

- **UART input “+++”, after module receive “+++”, and feedback “a” as confirmation.**
- **UART input “a”, after module receive “a” and feedback “+ok” to go into AT+instruction set configuration mode.**

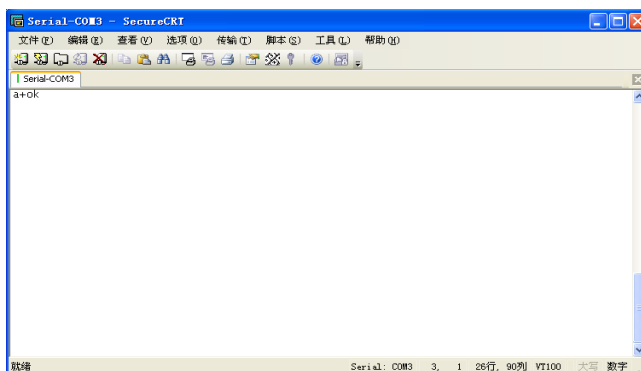
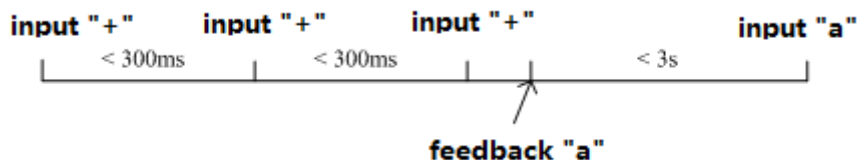

Figure 66. Switch to Configuration Mode

Notes:

1. When user input “+++” (No “Enter” key required), the UART port will display feedback information “a”, and not display input information”+++” as above UART display.

2. Any other input or wrong step to UART port will cause the module still works as original mode (transparent transmission).
3. “+++” and “a” should be input in a certain period of time to make the module switch to configuration mode. Like the following sequence.



4.1.2. Send AT Command in Transparent Transmission Mode

After set AT+CMDPW command value, the module support response AT command for special data format as “prefix”+“AT comman”+“\r”, it is very useful for query some status in transparent transmission mode. It saves the steps of changing to AT command mode.

The following example, we first set AT+CMDPW=HF, then send the following data in transparent mode, and get the AT command response. This data won't be sent to socket.

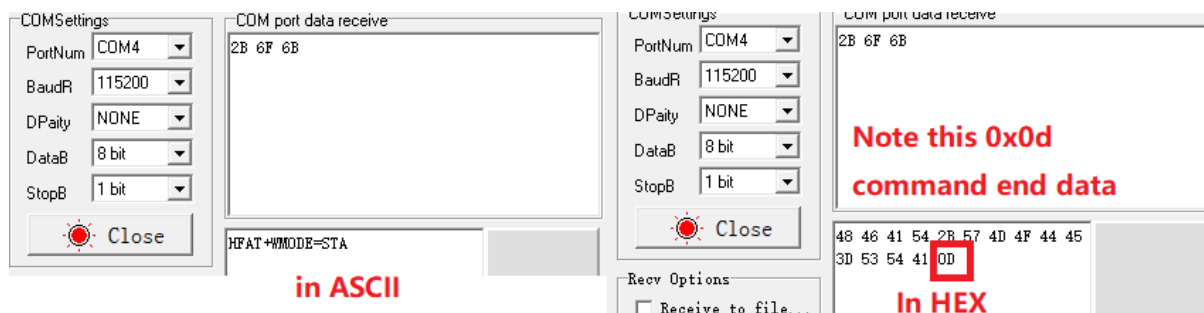

4.2. AT+Instruction Set Overview

User can input AT+Instruction through hyper terminal or other serial debug terminal, also can program the AT+Instruction to script. User can also input “AT+H” to list all AT+Instruction and description to start.

```

AT+H
+ok

AT+: NONE command, reply "+ok".
AT+ASWD: Set/Query wifi configuration code.
AT+E: Echo ON/off, to turn on/off command line echo function.
AT+ENTM: Goto Through Mode.
AT+NETP: Set/Get the Net Protocol Parameters.
AT+UART: Set/Get the UART Parameters.
AT+UARTF: Enable/disable UART AutoFrame function.
AT+UARTFT: Set/Get time of UART AutoFrame.
AT+UARTFL: Set/Get frame length of UART AutoFrame.
AT+UARTTE: Set/Query UART free-frame triggerf time between two byte.
AT+PING: General PING command.
AT+WAP: Set/Get the AP parameters.
AT+WKEY: Set/Get the Security Parameters of WIFI AP Mode.
AT+WMODE: Set/Get the WIFI Operation Mode (AP or STA).
AT+WSKEY: Set/Get the Security Parameters of WIFI STA Mode.
AT+WSSSID: Set/Get the AP's SSID of WIFI STA Mode.
AT+WSLK: Get Link Status of the Module (Only for STA Mode).
AT+WSQLQ: Get Link Quality of the Module (Only for STA Mode).
AT+WSCAN: Get The AP site Survey (only for STA Mode).
AT+WEBU: Set/Get the Login Parameters of WEB page.
AT+TCPK: Get The state of TCP link.
AT+TCPTO: Set/Get TCP time out.
AT+TCPDIS: Connect/Dis-connect the TCP client link
AT+RCV: Rcv data from UART
AT+SEND: Send data to UART
AT+WANN: Set/Get The WAN setting if in STA mode.
AT+LANN: Set/Get The LAN setting if in ADHOC mode.
AT+RELD: Reload the default setting and reboot.
AT+RLDEN: Put on/off the GPIO12.
AT+Z: Reset the Module.
AT+MID: Get The Module ID.
AT+VER: Get application version.
AT+H: Help.

```

Figure 67. "AT+H" Instruction for Help

4.2.1. Instruction Syntax Format

AT+Instruction protocol is based on the instruction of ASCII command style, the description of syntax format as follow.

- **Format Description**
 - < >: Means the parts must be included
 - []: Means the optional part

- **Command Message**

AT+<CMD>[op][para-1,para-2,para-3,para-4...]<CR>

- AT+: Prefix of command message;
- CMD: Command string;
- [op]: Symbol of command operator,
 - ◆ "=" : The command requires parameters input;
 - ◆ "NULL": Query the current command parameters setting;
- [para-n]: Parameters input for setting if required;
- <CR>:"Enter" Key, it's 0x0a or 0x0d in ASCII;

Notes: When input AT+Instruction, "AT+<CMD>" character will display capital letter automatic and other_parts will not change as you input.

- **Response Message**

+<RSP>[op] [para-1,para-2,para-3,para-4...]<CR><LF><CR><LF>

- +: Prefix of response message;
- RSP: Response string;
 - ◆ “ok” : Success
 - ◆ “ERR”: Failure
- [op] : =
- [para-n]: Parameters if query command or Error code when error happened;
- <CR>: ASCII 0x0d;
- <LF>: ASCII 0x0a;

➤ **Error Code**

Table13. Error Code Description

Error Code	Description
-1	Invalid Command Format
-2	Invalid Command
-3	Invalid Operation Symbol
-4	Invalid Parameter
-5	Operation Not Permitted

4.2.2. AT+Instruction Set

Table14. AT+Instruction Set List

Instruction	Description
<null>	NULL
Management Instruction Set	
E	Open/Close show back function
CMDPW	Set/Query AT command prefix character for sending AT command in throughput mode
WEL	Set/Query boot welcome message
EVENT	Set/Query event notification function
WMODE	Set/Query Wi-Fi work mode (AP/STA)
ENTM	Set module into transparent transition mode
TMODE	Set/Query module data transfer mode
MID	Query module ID information
VER	Query module software version information
BVER	Query Bootloader version
HWVER	Query Wi-Fi chip hardware version
RELD	Restore to factory default setting
FCLR	Erase factory setting
Z	Re-start module
H	Help
Configure Parameters Instruction Set	
CFGTF	Copy User Parameters to Factory Default Parameters
UART Instruction Set	
UART	Set/Query serial port parameters
Network Instruction Set	

Instruction	Description
PING	Network "Ping" Instruction
NETP	Set/Query SOCKA network protocol parameters
NETPIDEN	Set/query whether display from which communication channel the data comes from
NETPID	Set/query the communication channel number tag value.
MAXSK	Set/Query SOCKA TCP Client connection number
TCPLK	Query if SOCKA TCP link already build-up
TCPTO	Set/Query SOCKA TCP timeout
TCPDIS	Open/Close SOCKA TCP link
SEND	Send Data at Command Mode
RECV	Receive Data at Command Mode
SOCKB	Set/Query SOCKB parameters
TCPDISB	Open/Close SOCKB TCP link
TCPTOB	Set/Query SOCKB TCP timeout
TCPLKB	Query if SOCKB TCP link already build-up
SNDB	Send data to SOCKB in Command Mode
RCVB	Receive data from SOCKB in Command Mode
UDPLCPT	Set/Query UDP local port of SOCKA and SOCKB
NREGEN	Set/Query Communication Channel Number Registration Package Function
NREGDT	Set/Query Communication Channel Number Registration Package Custom Data
NREGSND	Set/Query the Transmission Method of the Communication Channel Number Registration Package
HEART	Set/Query Communication Channel Number Heartbeat Packet Data
HTPTP	Set/query HTTP request type
HTPURL	Set/query HTTP url resources and version
HTPHEAD	Set/query HTTP header
MQTOPIC	Set/query MQTT topic content
MQLOGIN	Set/query MQTT login content.
MQID	Set/query MQTT login content.
Wi-Fi STA Instruction Set	
WSKEY	Set/Query STA security parameters
WSSID	Set/Query associated AP SSID parameters
WANN	Set/Query STA's network parameters
WSMAC	Set/Query module STA MAC address
WSLK	Query STA Wi-Fi link status
WSLQ	Query STA Wi-Fi signal strength
WSCAN	Scan AP
WSDNS	Set/Query STA static DNS server address
Wi-Fi AP Instruction Set	
LANN	Set/Query AP's network parameters
WAMAC	Set/Query Module AP MAC address parameters.
WAP	Set/Query AP Wi-Fi parameters
WAKEY	Set/Query AP security parameters
WADHCP	Set/Query AP DHCP Server status
WALK	Query MAC address of STA device connecting to module AP
WALKIND	Enable/Disable indication of connection status.

Instruction	Description
WAPMXSTA	Set/Query max STA devices supported for AP.
Remote Upgrade Instruction Set	
OTA	Upgrade Firmware
UPURL	Set/Query remote upgrade URL address
Network Time Set	
NTPRF	Set/Query time calibration interval
NTPEN	Enable/Disable time calibration function
NTPTM	Query time
NTPSER	Set/Query NTP server IP
Webpage Set	
PLANG	Set/Query webpage language
WEBU	Set/Query webpage login account
Others Instruction Set	
WRMID	Set module ID
ASWD	Set/Query WiFi configuration code
WPS	Start WPS function
SMTLK	Start SmartLink function
NDBGL	Set UART debug information
SMEM	Query RAM malloc status
WIFI	Enable/Disable Wi-Fi
SMARTAPCONFIG	Config SmartAPLink function
SMARTAPSTART	Start SmartAPLink function, only valid if SmartAPLink is enabled
BTWAIT	Enable/Disable UART bootloader function
DTIM	Set/Query Wi-Fi DTIM

4.2.2.1. AT+

- Function: Null command, used for if module in AT command mode;
- Format:
 - ◆ Query Operation

AT+<CR>

+ok<CR><LF><CR><LF>

If response with +ok, then module is in AT command mode.

4.2.2.2. AT+E

- Function: Open/Close show back function;
- Format:
 - ◆ Set Operation

AT+E=<status><CR>

+ok<CR><LF><CR><LF>

- Parameters:
 - ◆ status: Echo status
 - ◇ on: Open echo
 - ◇ off: Close echo

When HF-LPX30 module firstly switch from transparent transmission to configuration mode, show back status is open, input “AT+E” to close show back function, input“AT+E” again to open show back function, use AT+E=on/off command to save the echo status..

4.2.2.3. AT+CMDPW

- Function: Set/Query AT command prefix character for sending AT command in throughput mode. Setting is valid after reset;
- Format:
 - ◆ Query Operation
AT+CMDPW<CR>
+ok=<data><CR><LF><CR><LF>
 - ◆ Set Operation
AT+CMDPW=<data><CR>
+ok<CR><LF><CR><LF>
- Parameters:
 - ◆ mode: Default is blank for disable t 是 his function. The maximum is 20 chacter length, once has been set, the AT command in transparent transmission mode function is enabled (AT+H and AT+WSCAN are not supported). Do restore to factory operation to disable and clear the setting

When set this value to “HF”, then can get response of “+ok=STA”(Hex: 2B 6F 6B 3D 53 54 41) for send “HFAT+WMODE\r”(Hex: 48 46 41 54 2B 57 4D 4F 44 45 0D, AT command should end with 0D or 0A).

4.2.2.4. AT+WEL

- Function: Set/Query boot welcome message.
- Format:
 - ◆ Query Operation:
AT+WEL<CR>
+ok=<message><CR><LF><CR><LF>
 - ◆ Set Operation:
AT+WEL=<message><CR>
+ok<CR><LF><CR><LF>
- Parameter:
 - ◆ message: Bootup welcome message output, default is product type such as 【HF-LPT230】 ; If it is 【off】 , means this function be closed, max 10 bytes.

4.2.2.5. AT+EVENT

- Function: Set/Query event notification function. Setting is valid after reset.
- Format:
 - ◆ Query Operation:
AT+EVENT<CR>
+ok=<status><CR><LF><CR><LF>
 - ◆ Set Operation:
AT+EVENT=<status><CR>
+ok<CR><LF><CR><LF>
- Parameter:
 - ◆ status: Enable/Disable event notification function
 - off: Disable, default value.
 - on: Enable event notification funciton.

Meet with following condition, module output UART data initiatively.

Event Notification Data	Condition
+EVENT=SOCKA_ON	SOCKA connection success (TCP Client/Server, HTTP, MQTT)
+EVENT=SOCKA_OFF	SOCKA connection break (TCP Client/Server, HTTP, MQTT)

+EVENT=SOCKB_ON	SOCKB connection success (TCP Client)
+EVENT=SOCKB_OFF	SOCKB connection break (TCP Client)
+EVENT=CON_ON	STA Connect to router success
+EVENT=CON_OFF	STA Disconnect with router
+EVENT=DHCP_OK	STA DHCP got IP

4.2.2.6. AT+WMODE

- Function: Set/Query Wi-Fi work mode. Setting is valid after reset;

- Format:

- ◆ Query Operation

AT+WMODE<CR>

+ok=<mode><CR><LF><CR><LF>

- ◆ Set Operation

AT+WMODE=<mode><CR>

+ok<CR><LF><CR><LF>

- Parameters:

- ◆ mode:Wi-Fi work mode

- ◇ AP
- ◇ STA
- ◇ APSTA

4.2.2.7. AT+ENTM

- Function: Set module into transparent transmission mode;

- Format:

AT+ENTM<CR>

+ok<CR><LF><CR><LF>

When operate this command, module switch from configuration mode to transparent transmission mode.

4.2.2.8. AT+TMODE

- Function: Set/Query module data transfer mode. Setting is valid after reset.

- Format:

- ◆ Query Operation

AT+TMODE<CR>

+ok=<tmode><CR><LF><CR><LF>

- ◆ Set Operation

AT+TMODE=<tmode><CR>

+ok<CR><LF><CR><LF>

- Parameters:

- ◆ tmode: data transfer mode, include:

- ◇ throughput: throughput mode
- ◇ cmd: command mode

4.2.2.9. AT+MID

- Function: Query module ID information;
- Format:
 - ◆ Query Operation

AT+MID<CR>

+ok=<module_id><CR><LF><CR><LF>

- Parameters:
 - ◆ module_id: Module ID information;
 - ◇ HF-LPX30;

Notes: User can set this parameter through AT+WRMID.

4.2.2.10. AT+VER

- Function: Query module software version information;
- Format:
 - ◆ Query Operation

AT+VER<CR>

+ok=<ver><CR><LF><CR><LF>

- Parameters:
 - ◆ ver: Module software version information;

4.2.2.11. AT+BVER

- Function: Query Bootloader software version information;
- Format:
 - ◆ Query Operation

AT+BVER<CR>

+ok=<ver><CR><LF><CR><LF>

- Parameters:
 - ◆ ver: Ex:1M_U06 V3.0.06, 0xC09F8

4.2.2.12. AT+HWVER

- Function: Query Bootloader software version information;
- Format:
 - ◆ Query Operation

AT+HWVER<CR>

+ok=<ver><CR><LF><CR><LF>

- Parameters:
 - ◆ ver: Ex: U06,5

4.2.2.13. AT+RELD

- Function: module restore to factory default setting;
- Format:
 - ◆ Set Operation

AT+RELD<CR>

+ok=rebooting...<CR><LF><CR><LF>

When operate this command, module will restore to factory default setting and reboot.

4.2.2.14. AT+FCLR

- Function: Erase factory setting;
- Format:
 - ◆ Query Operation

AT+FCLR<CR>

+ok=<status><CR><LF><CR><LF>

4.2.2.15. AT+Z

- Function: Re-start module;
- Format:

AT+Z<CR>

4.2.2.16. AT+H

- Function: Help;
- Format:
 - ◆ Query Operation

AT+H<CR>

+ok=<command help><CR><LF><CR><LF>

- Parameters:
 - ◆ command help: command introduction;

4.2.2.17. AT+CFGTF

- Function: Copy User Parameters to Factory Default Parameters;
- Format:
 - ◆ Query Operation

AT+CFGTF<CR>

+ok=<status><CR><LF><CR><LF>

- Parameters:
 - ◆ status: feedback operation status;

4.2.2.18. AT+UART

- Function: Set/Query serial port parameters. Setting is valid after reset.
- Format:
 - ◆ Query Operation

AT+UART[=uart_num]<CR>

+ok=<baudrate,data_bits,stop_bit,parity,flowctrl><CR><LF><CR><LF>

- ◆ Set Operation

AT+UART=<baudrate,data_bits,stop_bit,parity,flowctrl>[,uart_num]<CR>

+ok<CR><LF><CR><LF>

- Parameters:
 - ◆ uart_num: UART Channel, the default is UART0.
 - 0: UART0 Channel

- ◆ baudrate:
 - ◇ 1200,1800,2400,4800,9600,19200,38400,56000,57600,115200,230400,380400,460800,921600,1000000,1500000,2000000,3000000,4000000
- ◆ data_bits:
 - ◇ 8
- ◆ stop_bits:
 - ◇ 1
- ◆ parity:
 - ◇ NONE
 - ◇ EVEN
 - ◇ ODD
- ◆ Flowctrl: (CTSRTS)
 - ◇ NFC: No hardware flow control
 - ◇ FC: hardware flow control

Our EVK USB to TTL support max 3Mbps, RS232 to TTL support 460800 max. When using high baud rate, first to check if other side device support such high rate.

4.2.2.19. AT+PING

- Function: Network “PING” Instruction.
- Format:
 - ◆ Set Operation

```
AT+PING=<ip[,count,size]><CR>
+ok=<sta><CR><LF><CR><LF>
```
- Parameters:
 - ◆ ip: ip address or domain name.
 - ◆ count: Ping command execute count times. Default is 1.
 - ◆ size: Ping packet size. Default is 32 bytes.
 - ◆ sta: feedback result
 - ◇ Success
 - ◇ Timeout
 - ◇ Unknown host

4.2.2.20. AT+NETP

- Function: Set/Query SOCKA network protocol parameters. Setting is valid immediately.
- Format:
 - ◆ Query Operation

```
AT+NETP<CR>
+ok=<protocol,CS,port,IP[,opt]><CR><LF><CR><LF>
```
 - ◆ Set Operation

```
AT+NETP=<protocol[,CS,port,IP[,opt]]><CR>
+ok<CR><LF><CR><LF>
```
- Parameters:
 - ◆ protocol:
 - ◇ TCP

- ◇ UDP
- ◇ HTTP
- ◇ MQTT
- ◆ CS: Network mode:
 - ◇ SERVER
 - ◇ CLIENT
- ◆ Port: protocol port ID: Decimal digit and less than 65535
- ◆ IP: Server's IP address when module set as client
- ◆ opt: optional parameter, **【TLS】**

If set as UDP SERVER, the module will save the IP address and port of the latest UDP packet received. The data will be sent to the saved IP address and port. If the module hasn't saved any IP address and port when power up. The data will be sent to the IP address and port which is set by this command.

If set as UDP,CLIENT, the data will always be sent to the IP address and port set by this command.

Setting Example

- AT+NETP=TCP,CLIENT,8899,192.168.1.1
- AT+NETP=TCP,CLIENT,80,www.baidu.com
- AT+NETP=MQTT,80,www.baidu.com
- AT+NETP=HTTP,80,www.baidu.com

2MB Flash version support TSL, setting is as following:

- AT+NETP=http,443,getman.cn,NULL,TLS
- AT+NETP=TCP,client,8899,192.168.1.1,TLS
- AT+NETP=TCP,client,443,getman.cn,TLS

4.2.2.21. AT+NETPIDEN

- Function: Set/query whether display from which communication channel the data comes from, and the setting will take effect after reset.
- Format:
 - ◆ Query Operation:
AT+NETPIDEN=<id><CR>
+ok=<id,status><CR><LF><CR><LF>
 - ◆ Set Operation:
AT+NETPIDEN=<id,status><CR>
+ok<CR><LF><CR><LF>
- Parameter:
 - ◆ id: Communication channel number, including the following parameters.
 - A: SOCKA channel.
 - B: SOCKB channel.
 - ◆ status: Status values, including the following parameters.
 - on: Enable.
 - off: Close, default **【off】** .

Under enabled status, increase the communication channel number tag value in the received data header, such as receiving data **【abc】** , and the actual serial port output **【#SOCKA#abc】** .

Under serial port transmission mode, user must increase the communication channel number tag value in the header, so that the data will only be sent to the specified channel. For example, you need to send data **【abc】** to the SOCKA channel, and the actual serial port needs to send **【#SOCKA#abc】** .

Under disabling mode, the data output by the serial port does not distinguish the communication channel number, and the data received by the serial port is sent to all communication channels pointing to the serial port number.

4.2.2.22. AT+NETPID

- Function: Set/query the communication channel number tag value.
- Format:
 - ◆ Query Operation:
AT+NETPID=<id><CR>
+ok=<id,value><CR><LF><CR><LF>
 - ◆ Set Operation:
AT+NETPID=<id,value><CR>
+ok<CR><LF><CR><LF>
- Parameter:
 - ◆ id: Communication channel number, including the following parameters.
 - A: SOCKA channel.
 - B: SOCKB channel.
 - ◆ value: Communication channel number mark, SOCKA default **【#SOCKA#】** , SOCKB default **【#SOCKB#】** , and so on, up to 10 characters.

4.2.2.23. AT+MAXSK

- Function: Set/ Query SOCKA TCP Client connection number.
- Format:
 - ◆ Query Operation
AT+MAXSK<CR>
+ok=<num><CR><LF><CR><LF>
 - ◆ Set Operation
AT+MAXSK=<num><CR>
+ok<CR><LF><CR><LF>
- Parameters:
 - ◆ num: TCP Client connection number. Range: 1~5. 5 is the default value it means when the module work in TCP server , it accepts max 5 TCP client connect to it.

4.2.2.24. AT+TCPLK

- Function: Query if SOCKA TCP link already build-up;
- Format:
 - AT+TCPLK<CR>**
+ok=<sta><CR><LF><CR><LF>
- Parameters:
 - ◆ sta.: if module already setup TCP link;
 - ◇ on: TCP link setup;
 - ◇ off: TCP link not setup;

4.2.2.25. AT+TCPTO

- Function: Set/Query SOCKA TCP timeout; Setting is valid after reset.
- Format:
 - ◆ Query Operation
AT+TCPTO<CR>
+ok=<time><CR><LF><CR><LF>
 - ◆ Set Operation
AT+TCPTO=<time ><CR>
+ok<CR><LF><CR><LF>

- Parameters:
 - ◆ time: TCP timeout time.
 - ◇ ≤ 600, (600s);
 - ◇ ≥ 0, (0 means no timeout);
 - ◇ Default, 300s;

Module begin to count time when TCP channel don't receive any data, clecherar time counter when TCP channel receive any data. If the time counter reaches the TCPTO, the tcp channel will be break. If the module work in TCP Client, it will connect the TCP server instantly and when the module work in TCP Server, the TCP client device should make the connection itself.

4.2.2.26. AT+TCPDIS

- Function: Open/Close SOCKA TCP client link;
- Format:
 - ◆ Query Opera

```
AT+TCPDIS<CR>
+ok=<sta><CR><LF><CR><LF>
```

- ◆ Set Operation

```
AT+TCPDIS =<sta[,opt]><CR>
+ok<CR><LF><CR><LF>
```

- Parameters:
 - ◆ sta.: Response with TCP client connection setting status,
 - ◇ On: Allow TCP client connection, default value.
 - ◇ off: Forbidden or break TCP Client connection
 - ◆ opt: function code, save to flash or not, option parameter. if not fill in, default is 0.
 - ◇ 0: setting not saved to flash
 - ◇ 1: setting saved to flash

When setting, “off” means close TCP client link. After finish this command, module disconnect TCP link and not connect again. “On” means open TCP link. After finish this command, module re-connect TCP server right away.

If set opt to 0, the setting won't saved to flash, module AT+TCPDIS is on by default, if set opt to 1, setting saved to flash, AT+TCPDIS status depends on previous setting.

4.2.2.27. AT+SEND

- Function: Send Data to SOCKA at Command Mode.
- Format:

```
AT+SEND=<data_lenth><CR>
+ok<CR><LF><CR><LF>
```

- Parameters:
 - ◆ data_lenth: Lenth of send data. Range: 0~1000 Byte

The UART port will wait 3 seconds for input after this command is sent OK. The data received from UART port is sent to SOCKA. If the interval of two bytes is more than 10ms, the data will be sent instantly.

4.2.2.28. AT+RECV

- Function: Receive Data from SOCKA at Command Mode.
- Format:
 - AT+RECV=<data_lenth><CR>**
 - +ok=< data_lenth, data_content><CR><LF><CR><LF>**
- Parameters:
 - ◆ data_lenth: Lenth of receive data. Range: 0~1000 Byte
 - ◆ data_content: contents of receive data.

If not receive any data in 3 second, then feedback +ok=0.

4.2.2.29. AT+SOCKB

- Function: Set/Query SOCKB parameters. Setting is valid immediately.
- Format:
 - ◆ Query Operation
 - AT+SOCKB<CR>**
 - +ok=<protocol,port,IP><CR><LF><CR><LF>**
 - ◆ Set Operation
 - AT+SOCKB=<protocol,port,IP><CR>**
 - +ok<CR><LF><CR><LF>**

- Parameters:
 - ◆ Protocol: Protocol type:
 - ◇ TCP: Only for TCP Client
 - ◇ UDP: UDP Client
 - ◇ UDPS: UDP Server
 - ◆ Port: Protocol Port in decimal, less than 65535
 - ◆ IP: Destination IP address, domain name is support

If set as UDP SERVER, the module will save the IP address and port of the latest UDP packet received. The data will be sent to the saved IP address and port. If the module hasn't saved any IP address and port when power up. The data will be sent to the IP address and port which is set by this command.

If set as UDP,CLIENT, the data will always be sent to the IP address and port set by this command.

4.2.2.30. AT+TCPDISB

- Function: Open/Close SOCKB TCP client link;
- Format:
 - ◆ Query Opera
 - AT+TCPDISB<CR>**
 - +ok=<sta><CR><LF><CR><LF>**
 - ◆ Set Operation
 - AT+TCPDISB=<sta[,opt]><CR>**
 - +ok<CR><LF><CR><LF>**
- Parameters:
 - ◆ sta.: Response with SOCKB TCP client connection setting status,

- ✧ On: Allow TCP client connection, default value.
- ✧ off: Forbidden or break TCP Client connection
- ◆ opt: function code, save to flash or not, option parameter. if not fill in, default is 0.
 - ✧ 0: setting not saved to flash
 - ✧ 1: setting saved to flash

When setting, “off” means close TCP client link. After finish this command, module disconnect TCP link and not connect again. “On” means open TCP link. After finish this command, module re-connect TCP server right away.

If set opt to 0, the setting won't saved to flash, module AT+TCPDISB is on by default, if set opt to 1, setting saved to flash, AT+TCPDISB status depends on previous setting.

4.2.2.31. AT+TCPTOB

- Function: Set/Query Operation SOCKB TCP timeout. Setting is valid after reset.
- Format:

- ◆ Query Operation

```
AT+TCPTOB<CR>
+ok=<time><CR><LF><CR><LF>
```

- ◆ Set Operation

```
AT+TCPTOB=<time ><CR>
+ok<CR><LF><CR><LF>
```

- Parameters
 - ◆ Time: TCP timeout
 - ✧ <= 600:600s
 - ✧ >=0:0 means no timeout
 - ✧ Default:300s

If the SOCKB TCP don't receive any data from TCP server for TCP tmeout setting, the module will break and reconnect the TCP server. If it receive data from server, the timeout counter will be clear.

4.2.2.32. AT+TCPLKB

- Function:Query SOCKB connection status
- Format:

```
AT+TCPLKB<CR>
+ok=<sta><CR><LF><CR><LF>
```

- Parameters:
 - ◆ sta.: SOCKB connection status
 - ✧ on: TCP connected
 - ✧ off: TCP disconnected

4.2.2.33. AT+SNDB

- Function: Send datas to SOCKB at Command Mode
- Format:

```
AT+SNDB=<data_lenth ><CR>
+ok<CR><LF><CR><LF>
```

- Parameters:
 - ◆ data_lenth: Lenth of send data. Range: 0~1000 Byte

The UART port will wait 3 seconds for input after this command is sent OK. The data received from UART port is sent to SOCKB. If the interval of two bytes is more than 10ms, the data will be sent instantly.

4.2.2.34. AT+RCVB

- Function: Receive datas from SOCKB at Command Mode
- Format:

AT+RCVB=<data_lenth><CR>

+ok=< data_lenth, data_content><CR><LF><CR><LF>

- Parameters:
 - ◆ data_lenth: Lenth of receive data. Range: 0~1000 Byte
 - ◆ data_content: contents of receive data.

If not receive any data in 3 second, then feedback +ok=0.

4.2.2.35. AT+UDPLCPT

- Function: Set/Query UDP local port of SOCKA and SOCKB.
- Format:

- ◆ Query Operation

AT+UDPLCPT<CR>

+ok=<porta,portb><CR><LF><CR><LF>

- ◆ Set Operation

AT+UDPLCPT=<porta,portb><CR>

+ok<CR><LF><CR><LF>

- Parameters
 - ◆ porta: UDP local port of SOCKA, 0: do not fix local UDP port.
 - ◆ portb: UDP local port of SOCKB, 0: do not fix local UDP port.

4.2.2.36. AT+NREGEN

- Function: Set/Query Communication Channel Number Registration Package Function
- Format:

- ◆ Query Operation:

AT+NREGEN=<id><CR>

+ok=<id,status><CR><LF><CR><LF>

- ◆ Set Operation:

AT+NREGEN=<id,status><CR>

+ok<CR><LF><CR><LF>

- Parameter:
 - ◆ id: Communication channel number, including the following parameters.
 - A: SOCKA channel.
 - B: SOCKB channel.
 - ◆ status: Status value, including the following parameter.
 - on: Enable.
 - off: Close, default **【off】** .

4.2.2.37. AT+NREGDT

- Function: Set/query communication channel number registration package function
- Format:

◆ Query Operation:

```
AT+NREGDT=<id><CR>
+ok=<id,value><CR><LF><CR><LF>
```

◆ Set Operation:

```
AT+NREGDT=<id,value><CR>
+ok<CR><LF><CR><LF>
```

■ Parameter :

- ◆ id: Communication channel number, including the following parameters.
 - A: SOCKA channel.
 - B: SOCKB channel.
- ◆ data: Custom data, up to 40bytes, % wildcard has special function, as an escape character, Use % to send data in HEX format(Ex. %25), it also support special strings as following.
 - %MAC: MAC address
 - %WSLQ: Wi-Fi status, 2 bytes, the first for Wi-Fi status(1: Connect router OK, 0: Not connect to router), the second for Wi-Fi signal strength, HEX format, Ex: 01 16

There are several ways to match custom data, such as:

The contents of the registration package are ASCII code 【ABCDEFGH】

➤ AT+NREGDT=A, ABCDEFGH

The contents of the registration package are hexadecimal 【0x01 0x02 0x03 0x04 0x05】

➤ AT+NREGDT=A,%01%02%03%04%05

The content of the registration package is MAC+ data 【355837089512343 0x00 0x01 0x02 0x03】

➤ AT+NREGDT=A,%MAC%00%01%02%03

4.2.2.38. AT+NREGSND

- Function: Set/Query the Transmission Method of the Communication Channel Number Registration Package
- Format:
 - ◆ Query Operation:

```
AT+NREGSND=<id><CR>
+ok=<id,type><CR><LF><CR><LF>
```
 - ◆ Set Operation:

```
AT+NREGSND=<id,type><CR>
+ok<CR><LF><CR><LF>
```
- Parameter:
 - ◆ id: Communication channel number, including the following parameters.
 - A: SOCKA channel.
 - B: SOCKB channel.
 - ◆ type: Sending method, including
 - link: Send when the connection is established, default 【link】
 - data: The registration packet as the header of each packet of data
 - both: Support both methods at the same time

4.2.2.39. AT+HEART

- Function: Set/query communication channel number heartbeat packet data
- Format:
 - ◆ Query Operation:

```
AT+HEART=<id><CR>
+ok=<id,time,mode,type,value><CR><LF><CR><LF>
```
 - ◆ Set Operation:

```
AT+HEART=<id,time,mode,type,value><CR>
+ok<CR><LF><CR><LF>
```
- Parameter:
 - ◆ id: channel number, send heartbeat packets to a specific channel, including the following parameters.

- A: SOCKA channel.
- B: SOCKB channel.
- 1: Serial port 1 channel.
- ◆ time: Heartbeat interval, default **【0】** seconds, disable heartbeat function, range 1~65535. When SOCKA is set as MQTT, this time is also used for MQTT heartbeat, default is 60
- ◆ data: Custom data, up to 38 bytes, support escape characters, please refer to AT+NREGDT command for details. When SOCKA is used for MQTT, this content is of no use.

4.2.2.40. AT+HTPTP

- Function: Set/query HTTP request type. Only valid for SOCKA for HTTP mode, setting will take effect after reset.
- Format:
 - ◆ Query Operation:
AT+HTPTP<CR>
+ok=<type,method><CR><LF><CR><LF>
 - ◆ Set Operation:
AT+HTPTP=<type[,method]><CR>
+ok<CR><LF><CR><LF>
- Parameter:
 - ◆ type: HTTP request type
 - GET: GET request
 - POST: POST request
 - ◆ method: HTTP data method, optional value, if not fill, default is 0 only POST request valid.
 - 0: Default value, received UART data is put in HTTP body.
 - 1: received UART data is put in HTTP url parameters, auto add “?” between url and parameters(UART received data)

4.2.2.41. AT+HTPURL

- Function: Set/query HTTP url resources and version. Only valid for SOCKA for HTTP mode, setting will take effect after reset.
- Format:
 - ◆ Query Operation:
AT+HTPURL<CR>
+ok=<path,version><CR><LF><CR><LF>
 - ◆ Set Operation:
AT+HTPURL=<path,version><CR>
+ok<CR><LF><CR><LF>
- Parameter:
 - ◆ path: url resource, 50 characters length maximum, default: /abcd
 - ◆ version: HTTP protocol version, 1.0 or 1.1 default: 1.1

4.2.2.42. AT+HTPHEAD

- Function: Set/query HTTP header. Only valid for SOCKA for HTTP mode, setting will take effect after reset.
- Format:
 - ◆ Query Operation:
AT+HTPHEAD<CR>
+ok=<header><CR><LF><CR><LF>
 - ◆ Set Operation:
AT+HTPURL=<header><CR>
+ok<CR><LF><CR><LF>
- Parameter:
 - ◆ header: HTTP header, for new line in header use “<CRLF><CRLF>”. 180 characters maximum.

```
AT+HTPHEAD=Host:1.1.1.1<CRLF><CRLF>
+ok
```

4.2.2.43. AT+MQTOPIC

- Function: Set/query MQTT topic content. Only valid for SOCKA for MQTT mode, setting will take effect after reset.
- Format:
 - ◆ Query Operation:

```
AT+MQTOPIC<CR>
+ok=<publish,subscribe><CR><LF><CR><LF>
```
 - ◆ Set Operation:

```
AT+MQTOPIC=<publish,subscribe[,opt]><CR>
+ok<CR><LF><CR><LF>
```
- Parameter:
 - ◆ publish: publish topic, default: %MAC/up, %MAC is module MAC address, show real MAC when query
 - ◆ subscribe: subscribe topic, default: %MAC/down

```
AT+MQTOPIC=%MAC/up,%MAC/down
+ok
AT+MQTOPIC
+ok=F0FE6BBD4656/up,F0FE6BBD4656/down
```
 - ◆ opt: option parameter, default is saved to flash if not fill in this.
 - ✧ 0: Not save to flash, used for scene that change topic frequently.
 - ✧ 1: Save to flash.

4.2.2.44. AT+MQLOGIN

- Function: Set/query MQTT login content. Only valid for SOCKA for MQTT mode, setting will take effect after reset.
- Format:
 - ◆ Query Operation:

```
AT+MQLOGIN<CR>
+ok=<user,password><CR><LF><CR><LF>
```
 - ◆ Set Operation:

```
AT+MQLOGIN=<user,password><CR>
+ok<CR><LF><CR><LF>
```
- Parameter:
 - ◆ user: login user
 - ◆ login: login password

4.2.2.45. AT+MQID

- Function: Set/query MQTT login content. Only valid for SOCKA for MQTT mode, setting will take effect after reset.
- Format:
 - ◆ Query Operation:

```
AT+MQID<CR>
+ok=<id><CR><LF><CR><LF>
```
 - ◆ Set Operation:

```
AT+MQID=<id><CR>
+ok<CR><LF><CR><LF>
```
- Parameter:
 - ◆ id: Client ID, must be different for each device, recommend to use MAC for this Client ID. Support %MAC for setting, show real MAC when query

```
AT+MQID=%MAC
+ok

AT+MQID
+ok=F0FE6BBD4656
```

4.2.2.46. AT+WSSSID

- Function: Set/Query Wi-Fi associated AP SSID parameters. Setting is valid after reset.
- Format:
 - ◆ Query Operation

```
AT+WSSSID<CR>
```

```
+ok=<ap's ssid><CR><LF><CR><LF>
```
 - ◆ Set Operation

```
AT+WSSSID=<ap's ssid ><CR>
```

```
+ok<CR><LF><CR><LF>
```
- Parameters:
 - ◆ ap's ssid: AP's SSID (Within 32 character);

4.2.2.47. AT+WSKEY

- Function: Set/Query STA security parameters. Setting is valid after reset.
- Format:
 - ◆ Query Operation

```
AT+WSKEY<CR>
```

```
+ok=<auth, encry, key><CR><LF><CR><LF>
```
 - ◆ Set Operation

```
AT+WSKEY=< auth, encry, key><CR>
```

```
+ok<CR><LF><CR><LF>
```
- Parameters:
 - ◆ auth: Authentication mode
 - ◇ OPEN
 - ◇ SHARED
 - ◇ WPAPSK
 - ◇ WPA2PSK
 - ◆ encry: Encryption algorithm
 - ◇ NONE: When “auth=OPEN”, effective
 - ◇ WEP-H: When “auth=OPEN” or “SHARED”, effective, in HEX format
 - ◇ WEP-A: When “auth=OPEN” or “SHARED”, effective, in ASCII format
 - ◇ TKIP: When “auth= WPAPSK” or “WPA2PSK”, effective
 - ◇ AES: When “auth= WPAPSK” “WPA2PSK”, effective
 - ◆ key: password. When encry is WEP-H, password is in HEX format, password length is 10 or 26. When encry is WEP-A, password is in ASCII format, password length is 5 or 13. When encry is TKIP or AES, password is in ASCII code, password length shall be 8~63.

4.2.2.48. AT+WANN

- Function: Set/Query STA network setting. Setting is valid after reset.

- Format:
 - ◆ Query Operation

```
AT+WANN<CR>
```

```
+ok=<mode,address,mask,gateway><CR><LF><CR><LF>
```
 - ◆ Set Operation

```
AT+WANN=< mode,address,mask,gateway ><CR>
```

```
+ok<CR><LF><CR><LF>
```
- Parameters:
 - ◆ mode: STA's IP network setting
 - ◇ static: Static IP
 - ◇ DHCP: Dynamic IP
 - ◆ address: STA IP address;
 - ◆ mask: STA subnet mask;
 - ◆ gateway: STA gateway address;

4.2.2.49. AT+WSMAC

- Function: Set/Query Module STA MAC address parameters. Setting is valid after reset.
- Format:
 - ◆ Query Operation

```
AT+WSMAC<CR>
```

```
+ok=<mac_address><CR><LF><CR><LF>
```
 - ◆ Set Operation

```
AT+WSMAC=<code,mac_address,key><CR>
```

```
+ok<CR><LF><CR><LF>
```
- Parameters:
 - ◆ code: security code
 - ◇ 8888 (default value)
 - ◆ Mac_address: module MAC address, such as ACCF23FF1234
 - ◆ key: encryption key. It is not allowed to change, contact us if need to change MAC.

4.2.2.50. AT+WSLK

- Function: Query STA WiFi link status
- Format:
 - ◆ Query Operation

```
AT+WSLK<CR>
```

```
+ok=<ret><CR><LF><CR><LF>
```
- Parameters:
 - ◆ ret
 - ◇ "Disconnected", if no WiFi connection;
 - ◇ "AP' SSID (AP's MAC") , if WiFi connection available;

4.2.2.51. AT+WSLKO

- Function: Query/Set STA WiFi connection order function.
- Format:

◆ Query Operation

AT+WSLKO<CR>

+ok=<order><CR><LF><CR><LF>

◆ Set Operation

AT+WSLKO=<order><CR>

+ok<CR><LF><CR><LF>

■ Parameters:

◆ Order: order scheme. When there is much same name and password SSID, If enable this order function, module will connect to the strongest signal strength. If disabled, it will connect to the first response AP(may connect to the weakest AP). Enable this function will cost 2 more seconds more first connect time.

- ◇ Enable: Enable order function.
- ◇ Disable: Disable order function.

4.2.2.52. AT+WSQL

■ Function: Query STA WiFi signal strength;

■ Format:

◆ Query Operation

AT+WSQL<CR>

+ok=<ret><CR><LF><CR><LF>

■ Parameters:

◆ ret

- ◇ "Disconnected", if no WiFi connection;
- ◇ "AP's WiFi signal strength" , if WiFi connection available;

4.2.2.53. AT+WSCAN

■ Function: Scan AP, max show 50 item;

■ Format:

AT+WSCAN<CR>

+ok=<ap_site><CR><LF><CR><LF>

■ Parameters:

◆ ap_site: AP searched.

```

AT+WSCAN
+ok=
Ch,SSID,BSSID,Security,Indicator
4,TP-LINK_686E,24:69:68:7F:68:6E,WPA2PSK/AES,100
7,Upd,7C:B5:40:4F:B2:CD,WPA2PSK/AES,100
5,UPGRADE-AP_aaaa,C8:3A:35:54:B3:70,WPA2PSK/AES,100
7,LBLINK,3C:33:00:A8:35:2C,WPA2PSK/AES,100
    
```

4.2.2.54. AT+WSDNS

■ Function: Set/Query STA static DNS server address;

■ Format:

◆ Query Operation

AT+WSDNS<CR>

+ok=<address><CR><LF><CR><LF>

- ◆ Set Operation

AT+WSDNS =<address><CR>

+ok<CR><LF><CR><LF>

- Parameters:

- ◆ address: STA's DNS server address; Effective right away.

4.2.2.55. AT+LANN

- Function: Set/Query AP's network parameters. Setting is valid after reset.

- Format:

- ◆ Query Operation

AT+LANN<CR>

+ok=<ipaddress,mask><CR><LF><CR><LF>

- ◆ Set Operation

AT+LANN=< ipaddress,mask><CR>

+ok<CR><LF><CR><LF>

- Parameters:

- ◆ ipaddress: AP's IP address;
- ◆ mask: AP's net mask;

4.2.2.56. AT+WAMAC

- Function: Set/Query Module AP MAC address parameters.

- Format:

- ◆ Query Operation

AT+WAMAC<CR>

+ok=<mac_address><CR><LF><CR><LF>

AP MAC is related to STA MAC. The calculation method is as following.

```
if(macaddr[0] & 0x04)
    macaddr[0] &= 0xFB;
else
    macaddr[0] |= 0x04;
```

Ex:

STA MAC: 98D86323D16E

AP MAC: 9CD86323D16E

STA MAC: 34EAE723D16E

AP MAC: 30EAE723D16E

4.2.2.57. AT+WAP

- Function: Set/Query AP Wi-Fi parameters. Support maximum 5 STA connection. Setting is valid after reset.

- Format:

- ◆ Query Operation

AT+WAP<CR>

+ok=<wifi_mode,ssid,channel><CR><LF><CR><LF>

- ◆ Set Operation

AT+WAP =<wifi_mode,ssid,channel><CR>

+ok<CR><LF><CR><LF>

- Parameters:
 - ◆ wifi_mode: Wi-Fi mode, include:
 - ◇ 11B
 - ◇ 11BG
 - ◇ 11BGN (Default Value)
 - ◆ ssid:SSID at AP mode, the maximum length is 32.
 - ◆ channel: Wi-Fi channel selection:
 - ◇ AUTO;(Default CH1)
 - ◇ CH1~CH11;

4.2.2.58. AT+WAKEY

- Function: Set/Query AP Wi-Fi security parameters. Setting is valid after reset.
- Format:
 - ◆ Query Operation

AT+WAKEY<CR>

+ok=<auth,encry,key><CR><LF><CR><LF>

- ◆ Set Operation

AT+WAKEY=< auth,encry,key><CR>

+ok<CR><LF><CR><LF>

- Parameters:
 - ◆ auth: include
 - ◇ OPEN
 - ◇ WPA2PSK
 - ◆ Encry: include
 - ◇ NONE: When “auth=OPEN” available;
 - ◇ AES: When “auth=WPA2PSK” available;
 - ◆ key: security code, ASCII code, 8~63 bytes.

4.2.2.59. AT+WADHCP

- Function: Set/Query AP DHCP server status; Setting is valid after reset.
- Format:
 - ◆ Query Operation

AT+WADHCP<CR>

+ok=<status>,<ip1>,<ip2><CR><LF><CR><LF>

- ◆ Set Operation

AT+WADHCP=<status>[,ip1,ip2]<CR>

+ok<CR><LF><CR><LF>

- Parameters:
 - ◆ status:AP’s DHCP server function status:
 - ◇ on:DHCP Server Open;
 - ◇ off:DHCP Server Close;
 - ◆ ip1: DHCP allocate IP start value.

- ◆ ip2: DHCP allocate IP end value.

4.2.2.60. AT+WALK

- Function: Query MAC address of STA device connecting to module AP

- Format:

- ◆ Query Operation

AT+WALK<CR>

+ok=<status> <CR><LF><CR><LF>

- Parameters:

- ◆ status: MAC address of STA device connecting to module AP.
 - ✧ No Connection: No STA device connecting to module AP;

4.2.2.61. AT+WALKIND

- Function: Enable/Disable indication of module AP connection status.

- Format:

- ◆ Query Operation

AT+WALKIND<CR>

+ok=<status> <CR><LF><CR><LF>

- ◆ Set Operation

AT+WALKIND=<status><CR>

+ok<CR><LF><CR><LF>

- Parameters:

- ◆ status: indication of module AP connection status.
 - ✧ on: Enable nLink indication function. When STA device connecting to module AP, nLink output Low, otherwise output High.
 - ✧ off: Disable nLink indication function. **(default mode)**.

4.2.2.62. AT+WAPMXSTA

- Function: Set/Query max STA number supported for AP.

- Format:

- ◆ Query Operation

AT+WAPMXSTA<CR>

+ok=<num> <CR><LF><CR><LF>

- ◆ Set Operation

AT+WAPMXSTA=<num><CR>

+ok<CR><LF><CR><LF>

- Parameters:

- ◆ num: max STA number supported for AP.
 - ✧ 1~5: Support max 1~5 STA devices connects to module AP. **5 is default value for max 5 STA device supported.**

4.2.2.63. AT+MDCH

- Function: Set Wi-Fi Auto Switch Function. Setting is valid after reset.

- Format:

- ◆ Query Operation

AT+MDCH<CR>

+ok=<mode><CR><LF><CR><LF>

- ◆ Set Operation

AT+MDCH=<mode> <CR><LF><CR><LF>

+ok<CR><LF><CR><LF>

- Parameters:

- ◆ mode: Wi-Fi Auto Switch Mode
 - ◇ off: Disable Wi-Fi auto switch. When response with auto, it is the same as off.
 - ◇ on: Enable Wi-Fi auto switch. When the module(STA mode) fail to connect to router, it will switch to AP mode itself in one minute.

4.2.2.64. AT+OTA

- Function: Set OTA Upgrade

- Format:

- ◆ Set Operation

AT+OTA<CR>

+ok=<CR><LF><CR><LF>

Note: See Appendix C Module Upgrade for detail

4.2.2.65. AT+UPURL

- Function: Set/ Query remote upgrade URL address;

- Format:

- ◆ Query Operation

AT+UPURL<CR>

+ok=<url><CR><LF><CR><LF>

- ◆ Set Operation

AT+UPURL=<url,filename><CR>

+ok=<result><CR><LF><CR><LF>

- Parameters:

- ◆ url: the upgrade file url address; the last charter shall be "/" (within 20 characters).
- ◆ filename: the upgrade file name, it's optional and not saved parameter. If provide this file name here, the module will start upgrade right away;
- ◆ result: the download operation result.
 - Download failed: Url is error or file is not valid.
 - Update success: Need reboot to run new the download new firmware.

4.2.2.66. AT+DISPS

- Function: Set/Query power save parameters;

- Format:

- ◆ Query Operation

AT+DISPS<CR>

+ok=<ret><CR><LF><CR><LF>

- ◆ Set Operation

AT+DISPS=<mode[,time]><CR><LF><CR><LF>

- Parameters:
 - ◆ ret:
 - ◇ No: Enable power save
 - ◇ Yes: Disable power save
 - ◇ Auto: Auto power save mode(default), enter power saving mode after receive or send data in time seconds.
 - ◆ mode:
 - ◇ No: Enable power save
 - ◇ Yes: Disable power save
 - ◇ Auto: Auto power save mode(default), enter power saving mode after receive or send data in time seconds.
 - ◆ time: Only valid in auto mode, >=2 integer value, default is 3 seconds. when value is 0, the default waiting time is still 3 seconds.

4.2.2.67. AT+PLANG

- Function: Set/Query webpage language option;
- Format:
 - ◆ Query Operation

```
AT+PLANG<CR>
```

```
+ok=<language><CR><LF><CR><LF>
```
 - ◆ Set Operation

```
AT+PLANG=<language> <CR>
```

```
+ok<CR><LF><CR><LF>
```
- Parameters:
 - ◆ language: webpage's language
 - ◇ CN: Chinese Version (Default);
 - ◇ EN: English Version;

4.2.2.68. AT+WEBU

- Function: Set/ Query webpage user name and password; Setting is valid after reset.
- Format:
 - ◆ Query Operation

```
AT+WEBU<CR>
```

```
+ok=<username,password> <CR><LF><CR><LF>
```
 - ◆ Set Operation

```
AT+WEBU=<username,password><CR>
```

```
+ok<CR><LF><CR><LF>
```
- Parameters:
 - ◆ username: User Name, within 15 characters, not support empty.
 - ◆ password: password, within 15 characters, support empty.

4.2.2.69. AT+NTPRF

- Function: Set /Query time calibration interval
- Format:

- ◆ Query Operation

AT+NTPRF<CR>

+ok=<num><CR><LF><CR><LF>

- ◆ Set Operation

AT+NTPRF=<num><CR>

+ok<CR><LF><CR><LF>

- Parameters:

- ◆ num: time calibration interval, range:0~720, default:30 minutes, 10 minutes for each step, set 0 means no time calibration automatically.

4.2.2.70. AT+NTPEN

- Function: Enable/Disable time calibration function. Setting is valid after reset.

- Format:

- ◆ Query Operation

AT+NTPEN<CR>

+ok=<status><CR><LF><CR><LF>

AT+NTPEN=tz<CR>

+ok=<timezone><CR><LF><CR><LF>

- ◆ Set Operation

AT+NTPEN=<status[,timezone]><CR>

+ok<CR><LF><CR><LF>

- Parameters:

- ◆ status: status of time calibration
 - on: Enable time calibration
 - off: Disable time calibration
- ◆ timezone: timezone, default is 8, range -12~12.

4.2.2.71. AT+NTPTM

- Function: Query network time,time zone is GMT+8 by default.

- Format:

- ◆ Query Operation

AT+NTPTM<CR>

+ok=<time><CR><LF><CR><LF>

AT+NTPTM=F<CR>

+ok=<time><CR><LF><CR><LF>

- Parameters:

- ◆ time: network time, for example: 2013-10-9 16:10:42 Wed, if it shows Not Available means that the time calibration function is not enabled or the module doesn't connect to the internet.

AT+NTPTM query command runs with internal time, when connect to network, access RTC time from NTP server, then calibrate every AT+NTPRF command time setting.

AT+NTPTM=F query command always get RTC time from NTP server.

4.2.2.72. AT+NTPSER

- Function: Set/Query NTP server IP address.
- Format:
 - ◆ Query Operation

```
AT+NTPSER<CR>
```

```
+ok=<server><CR><LF><CR><LF>
```
 - ◆ Set Operation

```
AT+NTPSER=<server><CR>
```

```
+ok<CR><LF><CR><LF>
```
- Parameters:
 - ◆ server: NTP network server IP address, cn.ntp.org.cn (default value), domain name supports max 50 bytes.

4.2.2.73. AT+WRMID

- Function: Set module ID;
- Format:
 - ◆ Set Operation

```
AT+WRMID=<wrmid> <CR><LF><CR><LF>
```
- Parameters:
 - ◆ wrmid: set module's ID (within 20 characters).

4.2.2.74. AT+ASWD

- Function: Set/Query WiFi Configuration Password;
- Format:
 - ◆ Query Operation

```
AT+ASWD<CR>
```

```
+ok=<aswd> <CR><LF><CR><LF>
```
 - ◆ Set Operation

```
AT+ASWD=<aswd><CR><LF><CR><LF>
```
- Parameters:
 - ◆ aswd: WiFi Configuration Password (within 20 characters).

4.2.2.75. AT+SMTLK

- Function: Start SmartLink function
- Format:
 - ◆ Query Operation

```
AT+SMTLK<CR>
```

SmartLink is a One-Key config function. Config the module connecting to router easily. After start SmartLink function , the module work in SmartLink status and nLink LED is fast flashing waiting for APP to push information. See the Appendix for more details.

4.2.2.76. AT+WPS

- Function: Start WPS function
- Format:

- ◆ Query Operation

AT+WPS<CR>

+ok<CR><LF><CR><LF>

Note: The router WPS function must be open first then enable module WPS Scan function. The module will always in WPS mode if WPS is started. Only with success or reset can the module recover normal working mode.

4.2.2.77. AT+NDBGL

- Function: Enable/Disable UART debug information

- Format:

- ◆ Query Operation

AT+NDBGL<CR>

+ok=<debug_level,uart_num> <CR><LF><CR><LF>

- ◆ Set Operation

AT+NDBGL=<debug_level,uart_num><CR>

+ok<CR><LF><CR><LF>

- Parameters:

- ◆ debug_level: UART debug level value

- ◇ 0: Disable debug information output
- ◇ 1~XX: Output internal UART debug information which is same or higher then this set value

- ◆ uart_num: UART debug information output channel

- ◇ 0: UART0
- ◇ 1: UART1, 921600bps, with more system information output.

4.2.2.78. AT+TYPE

- Function: Set/Query WeChat device type.

- Format:

- ◆ Query Operation

AT+TYPE<CR>

+ok=<type> <CR><LF><CR><LF>

- ◆ Set Operation

AT+TYPE=<type><CR><LF><CR><LF>

- Parameters:

- ◆ type: WeChat device type. Ex: gh_ba0c25259dca.

4.2.2.79. AT+S MEM

- Function: Query the RAM malloc status.

- Format:

- ◆ Query Operation

AT+S MEM<CR>

+ok=<status><CR><LF><CR><LF>

- Parameters:

- ◆ status: The RAM malloc status. Ex for 1MB:

current_size:47016, max_size:41696, total_size:89984, alloc_cnt:42968, alloc_fail_cnt:0

4.2.2.80. AT+WIFI

- Function: Enable/Disable Wi-Fi Command

- Format:

- ◆ Query Operation

AT+WIFI<CR>

+ok=<status> <CR><LF><CR><LF>

- ◆ Set Operation

AT+WIFI =<status><CR>

+ok<CR><LF><CR><LF>

- Parameters:

- ◆ status: Wi-Fi status.
 - ◇ UP(boot default status): Enable Wi-Fi Chip
 - ◇ DOWN: Disable Wi-Fi Chip, it will take several seconds(max 10) to disable the Wi-Fi, if response with +ERR=-5 means disable failed, usually it is already in disable status.

Note: Some Wi-Fi status change command(AT+WMODE and so on)need to reboot before valid. But may use this command only to reboot the Wi-Fi Chip to make the corresponding command valid.This is AT+WIFI=DOWN,AT+WSSSID to set router information and then AT+WIFI=UP.

4.2.2.81. AT+SMARTAPCONFIG

- Function: Config SmartAPLink function

- Format:

- ◆ Query Operation

AT+SMARTAPCONFIG<CR>

+ok=<status,[ap_prefix,ap_key]><CR>< LF><CR>< LF>

- ◆ Set Operation

AT+SMARTAPCONFIG=<status,[ap_prefix,ap_key]><CR>

+ok<CR>< LF><CR>< LF>

- Parameters:

- ◆ status: Enable/Disable SmartAPLink function
 - ◇ on: Enable SmartAPLink function, after enabled, use AT+SMARTAPSTART or nReload to start config.
 - ◇ off: Disable SmartAPLink. Default.
- ◆ ap_prefix: module AP SSID prefix, default is hiflying_softap
- ◆ ap_key: module AP password, blank for no password, password length 8~20.
- ◆ ..

4.2.2.82. AT+SMARTAPSTART

- Function: Start SmartAPLink function, only valid if SmartAPLink is enabled.

- Format:

- ◆ Query Operation

AT+SMARTAPSTART<CR>

+ok<CR>< LF><CR>< LF>

Note: Reset to quit this config mode.

4.2.2.83. AT+BTWAIT

- Function: Enable/Disable UART bootloader function
- Format:
 - ◆ Query Operation

AT+BTWAIT<CR>

+ok=<status><CR>< LF><CR>< LF>

- ◆ Set Operation

AT+BTWAIT=<status><CR>

+ok<CR>< LF><CR>< LF>

- Parameters:
 - ◆ status: Enable/Disable UART bootloader, 3.0.8 version bootloader support this config
 - ◇ Enable: Enable UART bootloader, default value.
 - ◇ Disable: Disable..

Note: For LED application using nReload PIN for PWM output, if disable this UART bootloader, it will save about 1 second for bootup make the LED on more quickly.

4.2.2.84. AT+DTIM

- Function: Set/Query Wi-Fi DTIM
- Format:
 - ◆ Query Operation

AT+DTIM<CR>

+ok=<value><CR>< LF><CR>< LF>

- ◆ Set Operation

AT+DTIM=<value><CR>

+ok<CR>< LF><CR>< LF>

- Parameters:
 - ◆ value: 1~3, default is 1, means DTIM is 100ms

Note: Set to 3 for lower power consumption.

5. PACKAGE INFORMATION

5.1. Recommended Reflow Profile

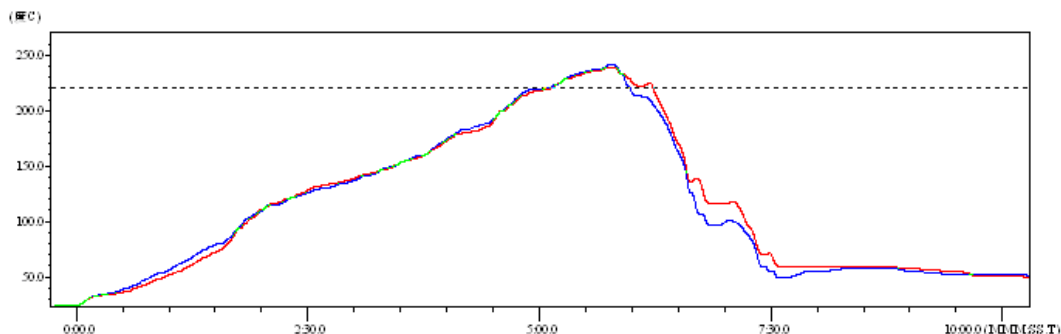

Figure 68. Reflow Soldering Profile

Table15. Reflow Soldering Parameter

NO.	Item	Temperature (Degree)	Time(Sec)
1	Reflow Time	Time of above 220	35~55 sec
2	Peak-Temp	260 max	

- Note:** 1. Recommend to supply N2 for reflow oven.
 2. N2 atmosphere during reflow (O2<300ppm)

5.2. Device Handling Instruction (Module IC SMT Preparation)

- Shelf life in sealed bag: 12 months, at <30°C and <60% relative humidity (RH).
- After bag is opened, devices that will be re-baked required after last baked with window time 168 hours.
- Recommend to oven bake with N2 supplied
- Recommend end to reflow oven with N2 supplied
- Baked required with 24 hours at 125+/-5°C before rework process.
- Recommend to store at ≤10% RH with vacuum packing
- If SMT process needs twice reflow:
 - Top side SMT and reflow
 - Bottom side SMT and reflow

Case 1: Wifi module mounted on top side. Need to bake when bottom side process over 168 hours window time, no need to bake within 168 hours

Case 2: Wifi module mounted on bottom side, follow normal bake rule before process

Note: Window time means from last bake end to next reflow start that has 168 hours space.

5.3. HF-LPB130/HF-LPT230 Shipping Information



Figure 69. HF-LPB130/HF-LPT230 Shipping Information

Note:

- 1 tape = 900pcs
- 1 box = 5 tapes = 5 * 900 pcs = 4500pcs

5.4. HF-LPT130A Shipping Information

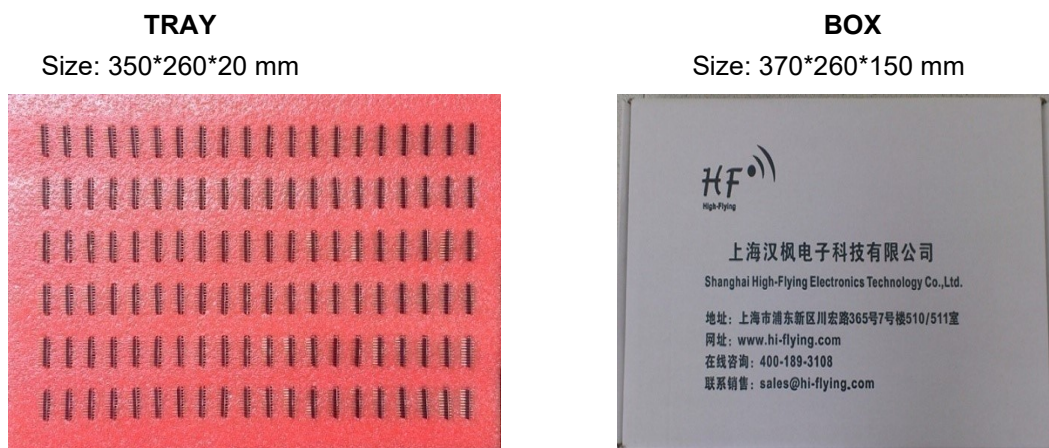
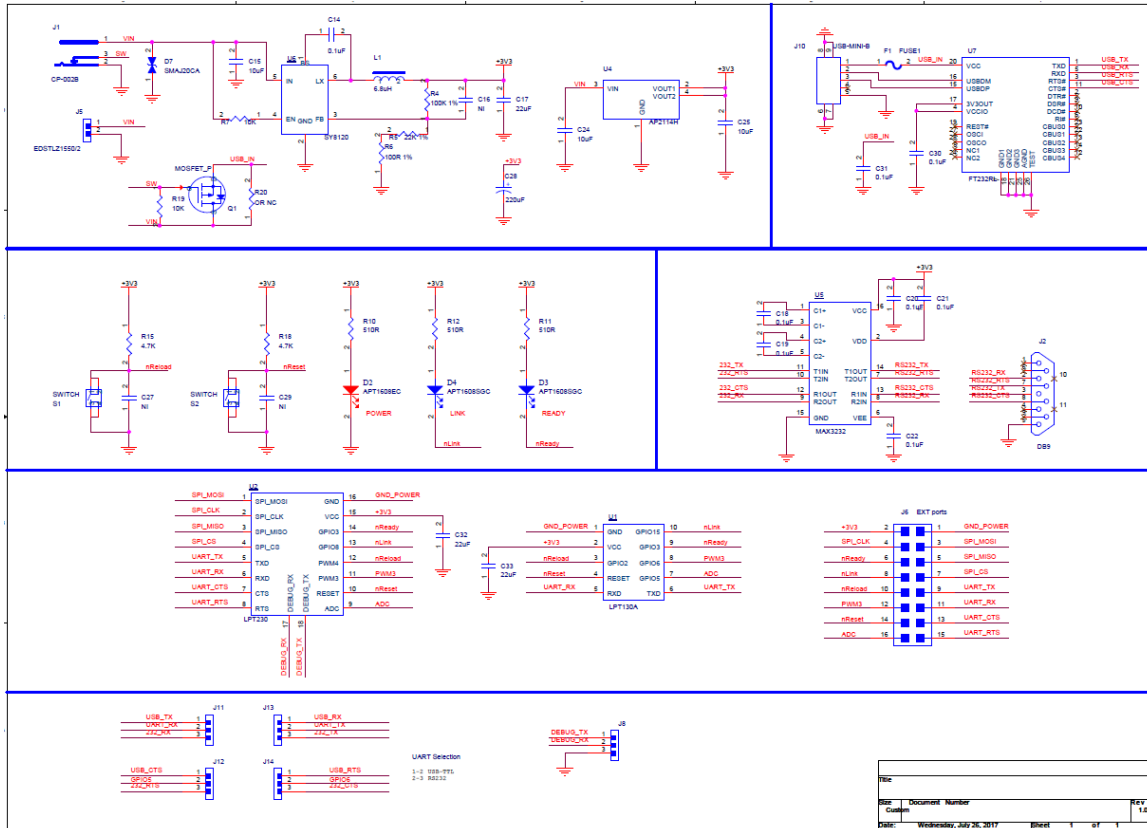

Figure 70. Shipping Information

Note:

- 1 tray = 20*6pcs = 120 pcs
- LPT130A: 1 box = 4 trays = 4 * 120 pcs = 480pcs

APPENDIX A: HW REFERENCE DESIGN



Detailed HF-LPX30 Evaluation Board design source files, pls access High-Flying web download page or contact with High-Flying technical support people to acquire.

APPENDIX B: HTTP PROTOCOL TRANSFER

HF-LPX30 module support http data transfer in throughput mode. If any detailed HTTP protocol, contact us and we may support customization.

B.1. Sending HTTP Raw Data in Throughput Mode

Step 1、Configure HTTP server information

```
AT+NETP=tcp,client,80,testnewjava.gotoip4.com
+ok
```

Step 2、Configure module connecting to router AP and reboot.

```
AT+WSSSID=Tenda_GYH
+ok

AT+WSKEY=wpa2psk,aes,12345678
+ok

AT+WMODE=sta
+ok

AT+Z
```

Step 3、Sending HTTP raw data via UART, end the data with<CR><LF><CR><LF>



APPENDIX C:REFERENCES

C.1. High-Flying Mass Production Tool

Download Address: <http://www.hi-flying.com/download-center-1/applications-1/download-item-production-tool>

C.2. SmartLink APP V8 Sniffer Config Tool

Download Address : <http://www.hi-flying.com/download-center-1/applications-1/download-item-smartlink-v8>

C.3. SDK

Download Address: <http://www.hi-flying.com/download-center-1/software-development-kit-1/download-item-hf-lpx30-hsf-sdk-1mb-2mb>

C.4. SmartAPLink APP

Download Address : <http://www.hi-flying.com/download-center-1/applications-1/download-item-smartaplink>

APPENDIX D: CONTACT INFORMATION

Web: www.hi-flying.com
Service Online: [400-189-3108/18616078755](tel:400-189-3108/18616078755)
Sales Contact: sales@hi-flying.com

For more information about High-Flying modules, applications, and solutions, please visit our web site
<http://www.hi-flying.com/en/>

<END OF DOCUMENT>

© Copyright High-Flying, May, 2011

The information disclosed herein is proprietary to High-Flying and is not to be used by or disclosed to unauthorized persons without the written consent of High-Flying. The recipient of this document shall respect the security status of the information.

The master of this document is stored on an electronic database and is "write-protected" and may be altered only by authorized persons at High-Flying. Viewing of the master document electronically on electronic database ensures access to the current issue. Any other copies must be regarded as uncontrolled copies.