

U_XPRO_Extension_TEMPLATE
88CKSCKT_XPRO_connector.SchDoc

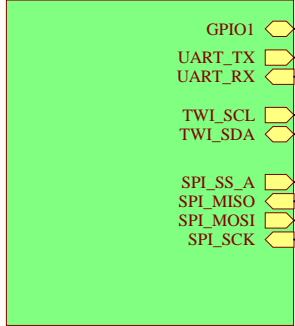

U_CryptoSheet
88CKSCKT_XPRO_Socket.SchDoc

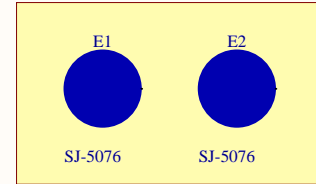
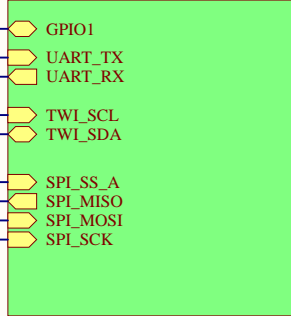

LABEL1

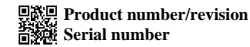

Label PCBA

BOM Variant Component Substitution Table

VARIANT NAME	PCBA DOC	TEST DOC	TEST SFTWR
SOIC Socket	A12-1175	A12-1172	A11-0350
UDFN Socket	A12-1176	A12-1173	A11-0351

Place PCB component here

PCB1

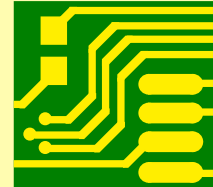

A08-2550
88CKSCKT PCB

Place PCBA, TEST, TESTDOC documentation components here

DOC1

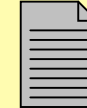

A12-1176

TESTDOC1

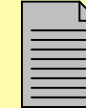

A12-1173

TEST1

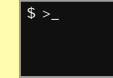

A11-0351

Drawn By:

Jim Boomer

Engineer:

Jim Boomer



Project Title

88CKSCKTSOIC-UDFN Socket boards

Sheet Title

XPRO_Extension_TopLevel_Template_4L

Size A4

PCB Assembly Number: *

PCBA Revision: 1

PCB Number: *

PCB Revision: *

Designed with

Altium

Altium.com

Date: 11/22/2017

Page: 1 of 3

Extension Identification

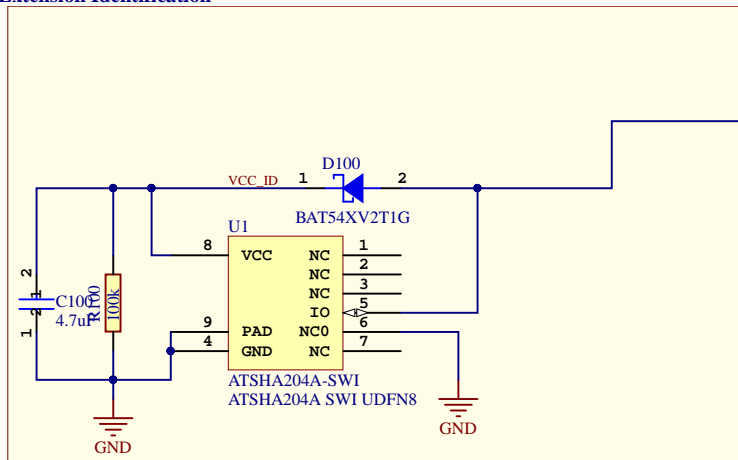

[DESIGN NOTE]
 The ATSHA204 is powered through an IO Pin from the EDBG on an MCU board.
 R100 is present to drain the capacitor C100 when power is removed from an MCU board.

Standard Extension Header (Female)

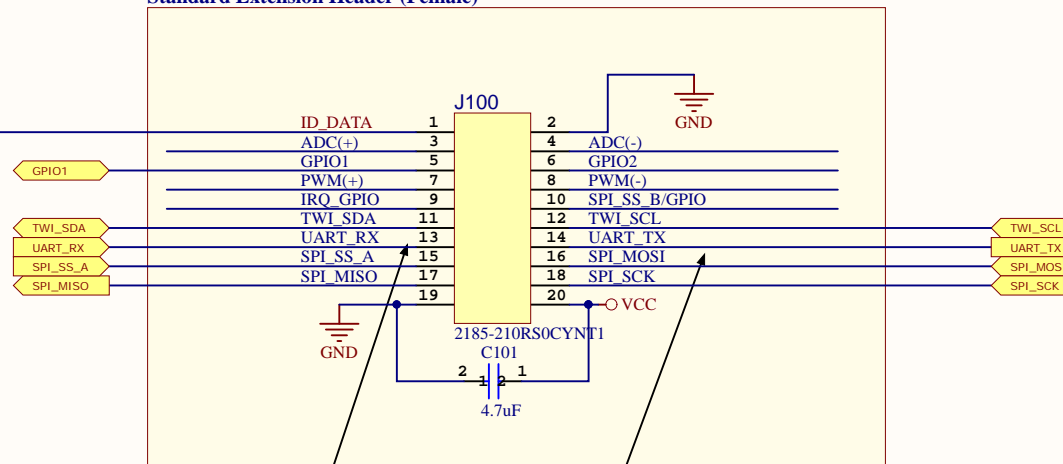

[DESIGN NOTE]
IMPORTANT NOTICE:
 UART_RX and UART_TX refer to RX (input) and TX (output) at the target device side. Connect UART_RX to TX of the UART device on the extension board and UART_TX to RX of the UART device on the extension board.

LED Power Circuit

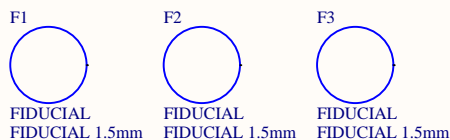
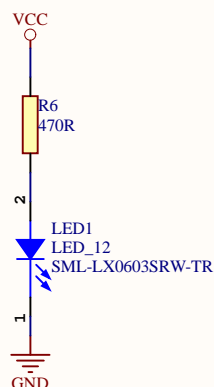

Drawn By: Jim Boomer		
Engineer: Jim Boomer		
Project Title *	Designed with 	
Sheet Title XPRO_Extension_Connector_Template_4L	Altium.com	
Size A4	PCB Assembly Number: *	PCBA Revision: 1
	PCB Number: *	PCB Revision: *
File: 88CKSKCT_XPRO_Connector.SchDoc	Date: 11/22/2017	Page: 2 of 3

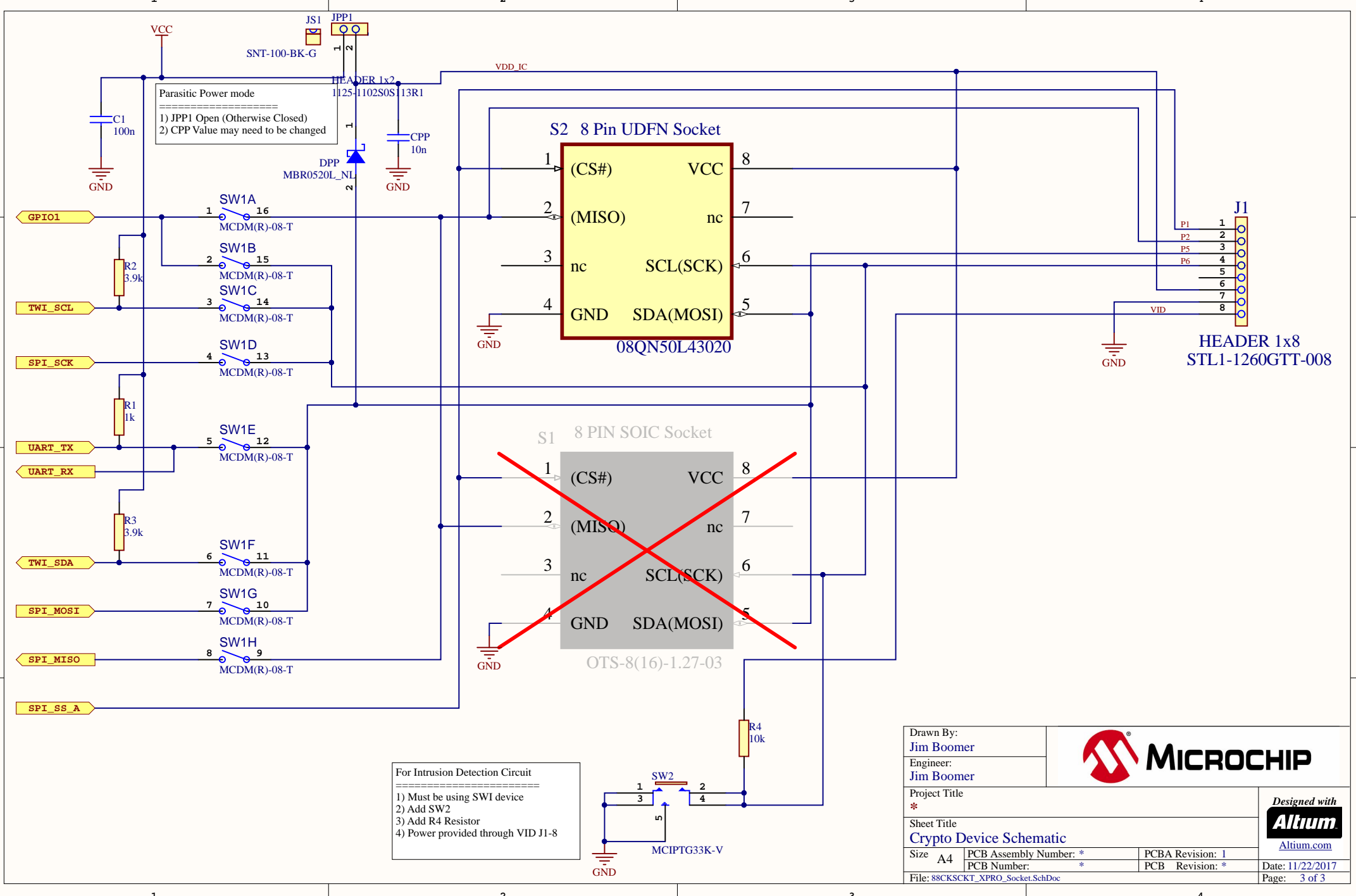

Parasitic Power mode

 1) JPP1 Open (Otherwise Closed)
 2) CPP Value may need to be changed

For Intrusion Detection Circuit

 1) Must be using SW1 device
 2) Add SW2
 3) Add R4 Resistor
 4) Power provided through VID J1-8

Drawn By: Jim Boomer		
Engineer: Jim Boomer		
Project Title *		
Sheet Title Crypto Device Schematic		
Size A4	PCB Assembly Number: *	PCBA Revision: 1
	PCB Number: *	PCB Revision: *
File: 88CKSCKT_XPRO_Socket.SchDoc		Date: 11/22/2017
		Page: 3 of 3



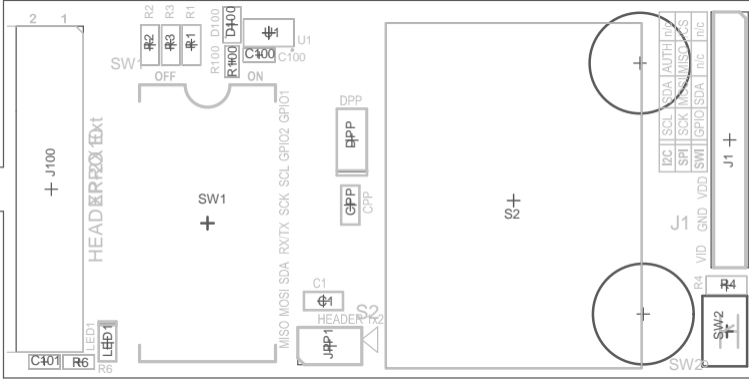

GN0 GN1 ADC_+ GNIOA PWM_+ SSB TWI_SCL UART_TX MOSI SCK VCC
ID-EXT ADC_+ GPIOB PWM_+ IRQ/SPWRM_SDA UART_RX SSA MISO GND

Microchip Corp© 2017

PCBA LABEL
A08-2550 Rev 3

88CKSCKT X PLAINED PRO

 MICROCHIP

MODE	S1	S2	S3	S4	S5	S6	S7	S8
SPI	OFF	OFF	OFF	ON	OFF	OFF	ON	ON
I2C	ON	OFF	ON	OFF	OFF	ON	OFF	OFF
QWI	OFF	ON	OFF	OFF	ON	OFF	OFF	OFF

Switch Settings

+

E1

E2

www.microchip.com/cryptokits

+

+

+

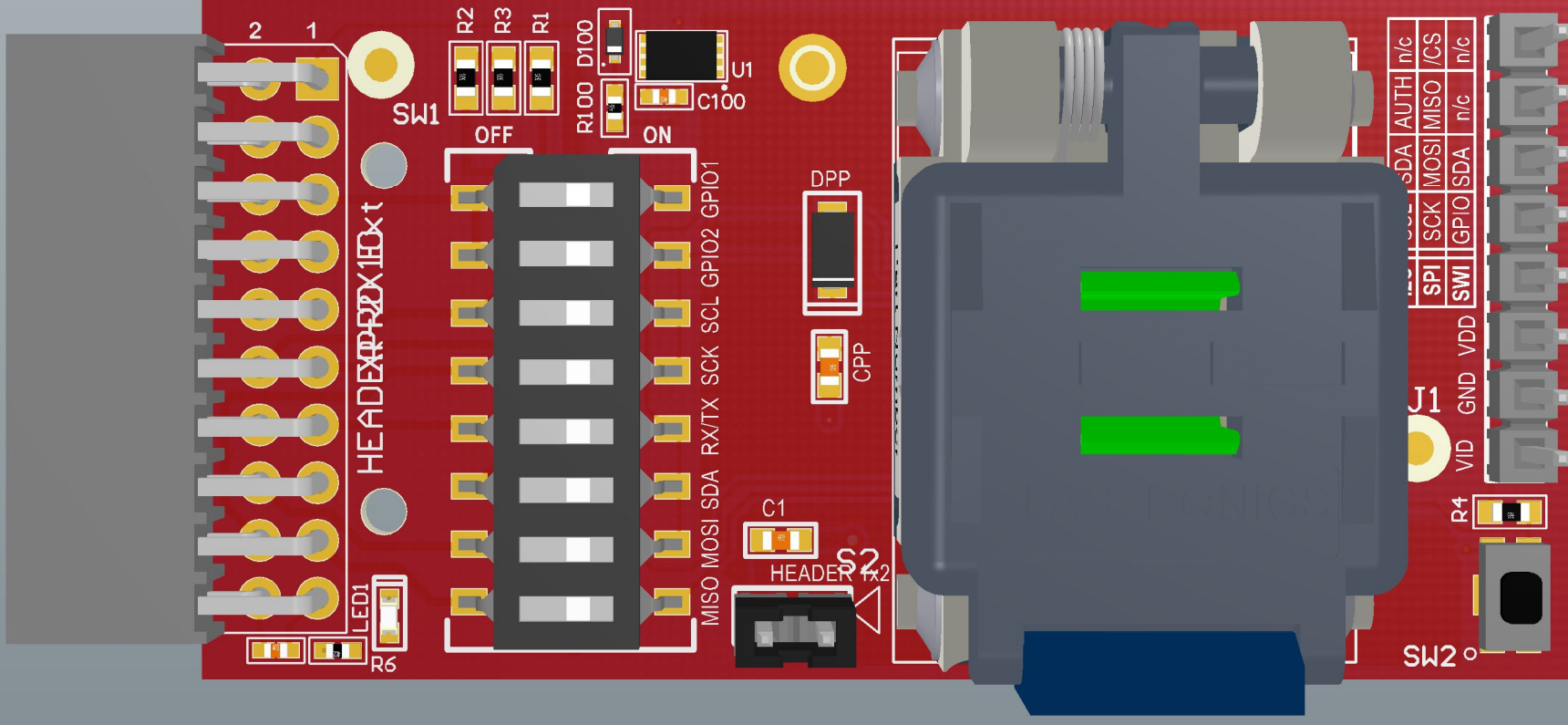

GND	ADC-	GPIOA	PWM-	SSB	TMU_SCL	UART_TX	MOSI	SCK	VCC
<input type="checkbox"/>	<input type="checkbox"/>	<input type="checkbox"/>	<input type="checkbox"/>	<input type="checkbox"/>	<input type="checkbox"/>	<input type="checkbox"/>	<input type="checkbox"/>	<input type="checkbox"/>	<input type="checkbox"/>
ID-EXT	ADC+	GPIOB	PWM+	IR/GPIO	TMU_SDA	UART_RX	SSA	MISO	GND
<input type="checkbox"/>	<input type="checkbox"/>	<input type="checkbox"/>	<input type="checkbox"/>	<input type="checkbox"/>	<input type="checkbox"/>	<input type="checkbox"/>	<input type="checkbox"/>	<input type="checkbox"/>	<input type="checkbox"/>

Microchip Corp© 2017

PCBA LABEL
A08-2550 Rev 3



88CKSCKT X PLAINED PRO



MODE	S1	S2	S3	S4	S5	S6	S7	S8
SPI	OFF	OFF	OFF	ON	OFF	OFF	ON	ON
I2C	ON	OFF	ON	OFF	OFF	ON	OFF	OFF
SW1	OFF	ON	OFF	OFF	ON	OFF	OFF	OFF

Switch Settings

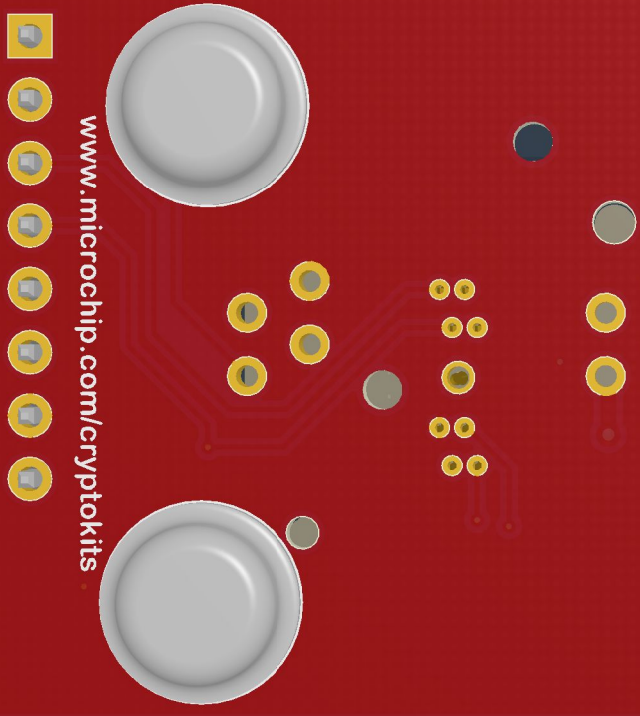

www.microchip.com/cryptokits

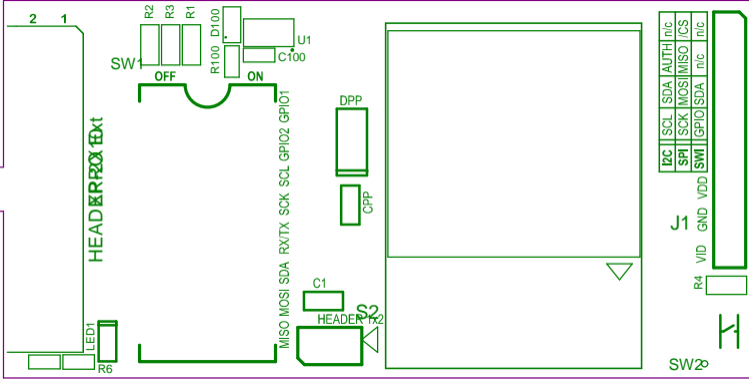

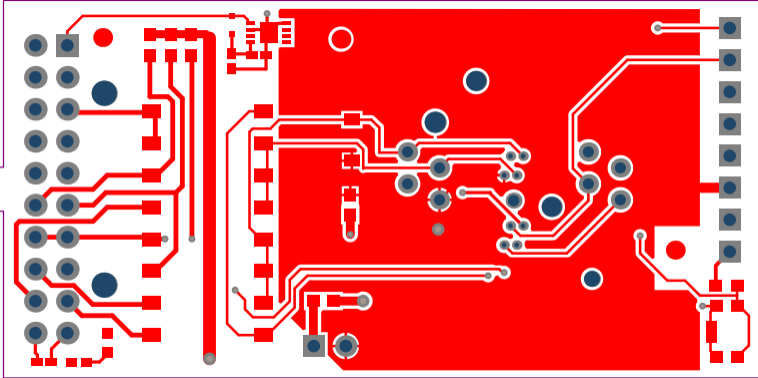

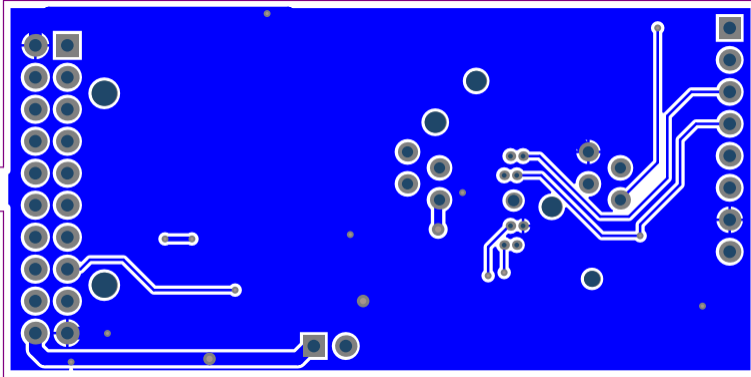



Switch Settings

SMI	OFF	ON	OFF	OFF	ON	OFF	OFF	OFF	OFF
ISC	ON	OFF	ON	OFF	OFF	ON	OFF	OFF	
SpI	OFF	OFF	OFF	ON	OFF	OFF	ON	ON	
MODE	21	25	23	24	22	29	27	28	



MICROCHIP

88CK2CK1

X

PLAINED PRO



A08-5P20 Rev 3
PCBA LABEL

Microchip Corp © 2017



IDEXT1 VDC+ GNIOB PNM+ IRO/GNIO TMI_3DV UVRT_RX 28V M3O GND

GND VDC- GNIOA PNM- 28B TMI_SCT UVRT_TX M0B 30X VCC

Component list

Bill of Materials Fitted For Variant [UDFN Socket] of Project [88CKSCKT_XPRO.PrjPCB] (No PCB Document Selected)

Source Data From: 88CKSCKT_XPRO.PrjPCB
 Project: 88CKSCKT_XPRO.PrjPCB
 Variant: UDFN Socket



Report Date: 11/22/2017 3:26:24 PM
 Print Date: 11/22/2017 3:21:25 PM

Fitted	Designator	Quantity	Value	Manufacturer	MPN	Description
Fitted	C1	1	100n	AVX	0603YC104KAT2A	Ceramic capacitor, SMD 0603, X7R, 16V, +/-10 %
Fitted	C100, C101	2	4.7uF	Murata	GRM155R60J475ME87D	Ceramic capacitor, SMD 0402, X5R, 6.3V, +/-20% (de33687)
Fitted	CPP	1	10n	tdk	C1608COG1H103J	Ceramic capacitor, SMD 0603, NPO, 50V, A±5%
Fitted	D100	1	BAT54XV2T1G	ON Semiconductor	BAT54XV2T1G	Schottky diode, If:200mA, Vf:0.35V, Vrrm:30V, SOD-523
Fitted	DOC1	1	A09-2650 PCB A Files			88CKSCKTUDFN PCB A Files
Fitted	DPP	1	MBR0520L_NL	Fairchild	MBR0520L_NL	SMD Schottky diode, 0.5A 20V
Fitted	E1, E2	2	SJ-5076	3M	SJ-5076	2.8mm adhesive feet,diam 8.0mm
Fitted	F1, F2, F3	3	FIDUCIAL 1.5mm			Fiducial point for PCB coordinates 1.5mm pad and 3mm hole in mask
Fitted	J1	1	STL1-1260GTT-008	Garry	STL1-1260GTT-008	1x8 Pin Header, 2.54mm pitch, THM, pin-in-paste, (MPN seems not be valid please use 087-1-008-0-T-XS0-1260 instead)
Fitted	J100	1	2185-210RS0CYNT1	WCON HARDWARE ELECTRONICS CO., LTD	2185-210RS0CYNT1	2x10, female pin header receptable, right-angled, 2.54mm pitch, THM, PIP
Fitted	JPP1	1	1125-1102S0S113R1	WCON HARDWARE ELECTRONICS CO., LTD	1125-1102S0S113R1	1x2 pin header, 2.54mm pitch, Pin-in-Paste THM
Fitted	JS1	1	SNT-100-BK-G	SAMTEC	SNT-100-BK-G	Jumper cap for 2.54mm pinheader
Fitted	LABEL1	1	Label PCBA	ACT Logimark AS	505462	PCBA identification label PP Top White Gloss
Fitted	LED1	1	SML-LX0603SRW-TR	Lumex	SML-LX0603SRW-TR	LED, Red, SMD 0603
Fitted	PCB1	1	88CKSCKT PCB			Common PCB Socket Board for 88CKSCKTISOIC/88CKSCKTUDFN/88CKSCTR BH
Fitted	R1	1	1k	KOA	RK73H1JTTD1001F	Thick film resistor, SMD 0603, 1/10W, 1%
Fitted	R100	1	100k			Thick film resistor, SMD 0402, 1/16W, 1%
Fitted	R2, R3	2	3.9k			Thick film resistor, SMD 0603, 1/10W, 1%
Fitted	R4	1	10k	KOA	RK73H1JTTD1002F	Thick film resistor, SMD 0603, 1/10W, 1%
Fitted	R6	1	470R			Thick film resistor, SMD 0402, 1/16W, 1%
Fitted	S2	1	8 Pin UDFN Socket	Plastronics	08QN50L43020	8 Pin UDFN Socket 0.5mm Pin Pitch (Package Size 2.0 x 3.0 mm)
Fitted	SW1	1	MCDM(R)-08-T	Multicomp	MCDM(R)-08-T	Switch 8W DIL SM Multicomp
Fitted	SW2	1	MCIPTG33K-V	Multicomp	MCIPTG33K-V	SMD SWITCH, 2.8X3.8MM VERTICAL PUSH
Fitted	TEST1	1	88CKSCKTUDFN Test			Fixture test for 88CKSCKTUDFN
Fitted	TESTDOC1	1	88CKSCKTUDFN XPRO Test Instructions			88CKSCKTUDFN XPRO Test Instructions
Fitted	U1	1	ATSHA204A SWI UDFN8	ATMEL	ATSHA204A-MAHCZ-T	ATSHA204A with 1-wire interface and UDFN8 package
Not Fitted	S1	0	8 PIN SOIC Socket	Enplas	OTS-8(16)-1.27-03	8 Pin SOIC Socket 1.27mm Pin Pitch (150 Mil Body Width)
		31				

Approved

Notes