

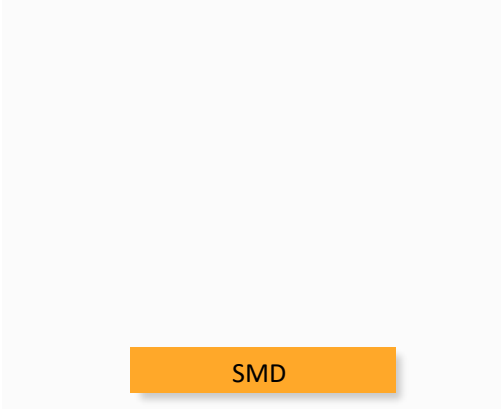

AM1LS-VZ



The new AM1LS-VZ is a DC/DC converter that is a direct replacement to the AM1L-NZ. Offering much greater cost effectiveness due to material normalization and production automation which increases the reliability and performance of this new component. Offering a commercial input voltage range of 5VDC and an output voltage range from 3.3-24V, this series will offer many benefits to your new system design.

This new series offers great operating temperatures, from -40°C to 105°C with full power up to 100°C. It also features an isolation of 1500VDC or 3000VDC for improved reliability and system safety. Furthermore, a higher MTBF of 3500,000h and output short circuit protection (OSCP) come standard with the series. The AM1LS-VZ is perfect for information technology, instrumentation, communication and civil applications.

Features



- No load input current as low as 5mA
- Operating Temp: -40 °C to +105 °C
- High I/O isolation voltage : 1500 to 3000 VDC
- Output short circuit protection
- High efficiency up to 85%
- SMD type package, Industry standard pin-out

Summary

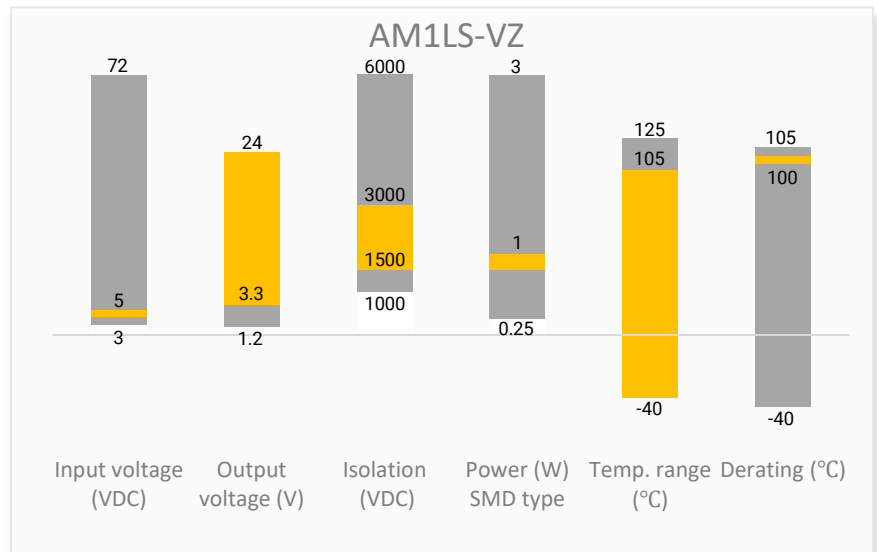

Training

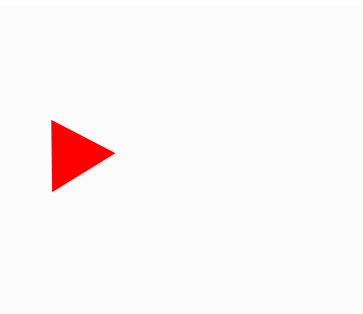

Product Training Video
(click to open)

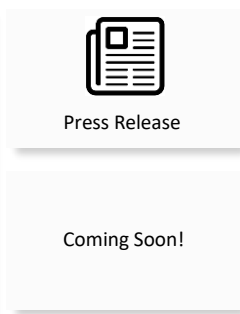

Application Notes

Applications



IoT



Industrial



Telecom



Instrumentation

Models & Specifications

Single Output

Model	Input Voltage (VDC)	Output Voltage (VDC)	Input Current Max (mA)		Output Current Max (mA)	Isolation (VDC)	Maximum Capacitive Load (μ F)	Efficiency (%) Full Load Typ.
			No Load	Full Load				
AM1LS-0503SVZ	5 (4.5 ~ 5.5)	3.3	10	286	303	1500	2400	74
AM1LS-0505SVZ	5 (4.5 ~ 5.5)	5	10	286	200	1500	2400	82
AM1LS-0509SVZ	5 (4.5 ~ 5.5)	9	20	254	111	1500	1000	83
AM1LS-0512SVZ	5 (4.5 ~ 5.5)	12	20	254	84	1500	560	83
AM1LS-0503SH30VZ	5 (4.5 ~ 5.5)	3.3	10	286	303	3000	2400	74
AM1LS-0505SH30VZ	5 (4.5 ~ 5.5)	5	10	286	200	3000	2400	82
AM1LS-0509SH30VZ	5 (4.5 ~ 5.5)	9	20	254	111	3000	1000	83
AM1LS-0512SH30VZ	5 (4.5 ~ 5.5)	12	20	254	84	3000	560	83
AM1LS-0515SH30VZ	5 (4.5 ~ 5.5)	15	30	254	67	3000	560	83
AM1LS-0524SH30VZ	5 (4.5 ~ 5.5)	24	30	254	42	3000	220	85

Dual Output

Model	Input Voltage (VDC)	Output Voltage (VDC)	Input Current Max (mA)		Output Current Max (mA)	Isolation (VDC)	Maximum Capacitive Load (μ F)	Efficiency (%) Full Load Typ.
			No Load	Full Load				
AM1LS-0503DH30VZ	5 (4.5 ~ 5.5)	\pm 3.3	10	286	\pm 151	3000	1200	74
AM1LS-0505DH30VZ	5 (4.5 ~ 5.5)	\pm 5	10	286	\pm 100	3000	1200	82
AM1LS-0509DH30VZ	5 (4.5 ~ 5.5)	\pm 9	20	254	\pm 56	3000	470	83
AM1LS-0512DH30VZ	5 (4.5 ~ 5.5)	\pm 12	20	254	\pm 42	3000	220	83
AM1LS-0515DH30VZ	5 (4.5 ~ 5.5)	\pm 15	30	254	\pm 34	3000	220	83
AM1LS-0524DH30VZ	5 (4.5 ~ 5.5)	\pm 24	30	254	\pm 21	3000	100	85

Input Specification

Parameters	Conditions	Typical	Maximum	Units
Voltage range	5	4.5 – 5.5		VDC
Filter	Capacitor			
Absolute maximum rating	1 sec, max		9	VDC
Input reflected ripple current		15		mA

Output Specification

Parameters	Conditions	Typical	Maximum	Units
Voltage accuracy	See Typical Characteristic			
Line regulation	Input voltage change : 1%	3.3V output model	1.5	%
		Others	1.2	

Preliminary

Load regulation	10 ~ 100% load	3.3V output model	15	20	%
		5V output model	10	15	
		9V output model	8	10	
		12V output model	7	10	
		15V output model	6	10	
		24V output model	5	10	
Temperature coefficient	Full load		±0.02		%/°C
Ripple & Noise	20MHz bandwidth	Others	30	75	mV pk-pk
		24V output model	50	100	

Note: Please refer to application notes for Ripple & Noise test information.

Isolation Specification				
Parameters	Conditions	Typical	Maximum	Units
Tested I/O voltage	60 sec, 1mA max	1500 / 3000		VDC
Resistance	Input to output resistance at 500Vdc	>1000		MOhm
Capacitance	Input to output, 100KHz/0.1V	20		pF

General Specifications				
Parameters	Conditions	Typical	Maximum	Units
Switching frequency	Full load, nominal input voltage	270		KHz
Operating temperature	See derating graph	-40 to +105		°C
Storage temperature		-55 to +125		°C
Case temperature rise	Ta = 25°C	3.3V output mode	25	°C
		Others	15	
Maximum case temperature			95	°C
Reflow Temperature	Maximum duration ≤60s over 217°C.		245	°C
Lead-free reflow solder process	IPC/JEDEC J-STD-020D.1			
Short circuit protection	Continuous, auto-recovery			
Cooling	Free air convection			
Humidity	Non-condensing		95	% RH
Case material	Heat resistant black Plastic (flammability to UL 94V-0)			
Weight	1.3			g
Dimensions (L x W x H)	0.60 x 0.45 x 0.29 inches, 15.24 x 11.40 x 7.25mm			
MTBF	> 3 500 000 hrs (MIL-HDBK -217F, t=+25°C) / Full Load			
Moisture sensitivity level (MSL)	IPC/JEDEC J-STD-020D.1	Level 1		

All specifications in this datasheet are measured at an ambient temperature of 25°C, humidity<75%, nominal input voltage and at rated output load unless otherwise specified.

Safety Specifications		
Parameters		
Standards	Design to meet IEC62368/UL62368/EN62368	
	EMC - Conducted and radiated emission	CISPR32/EN55032, Class B with recommended circuit
	Electrostatic Discharge Immunity	IEC 61000-4-2 Air ±8KV, Contact ±4KV, Criteria B

Typical Characteristic

3.3V output models

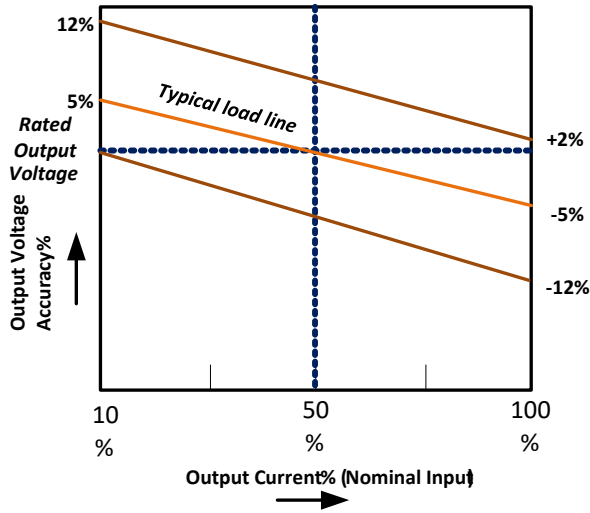

Other models

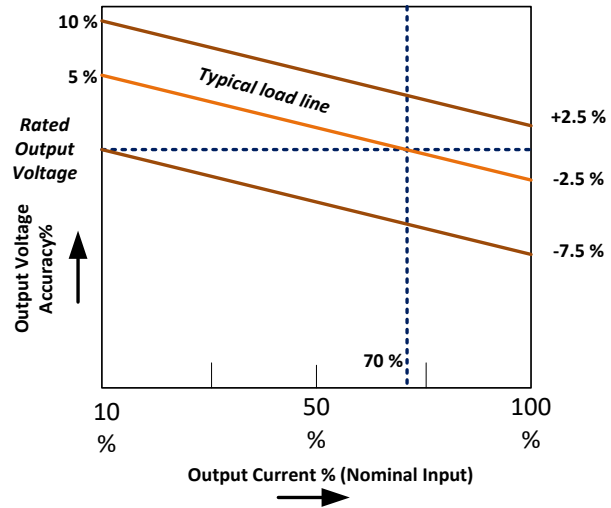

Derating

Nature Convection

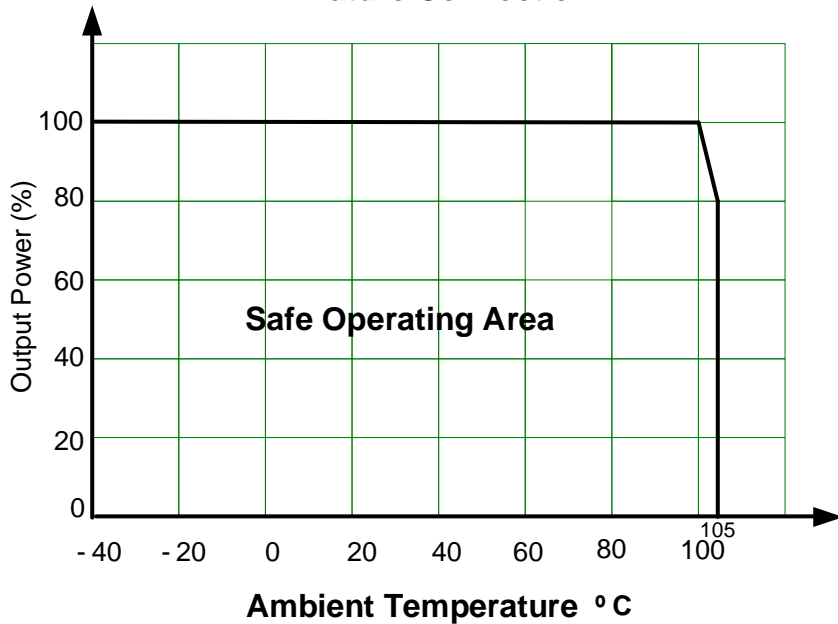

Typical Application Circuit

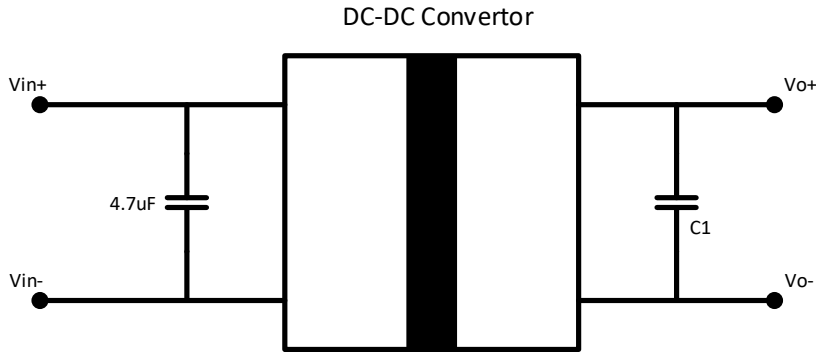

Capacitor selection Table

Output voltage	C1
3.3 V	10µF
5 V	10µF
9 V	4.7µF
12 V	2.2µF
15 V	1µF
24V	0.47µF

EMI Recommended Circuit

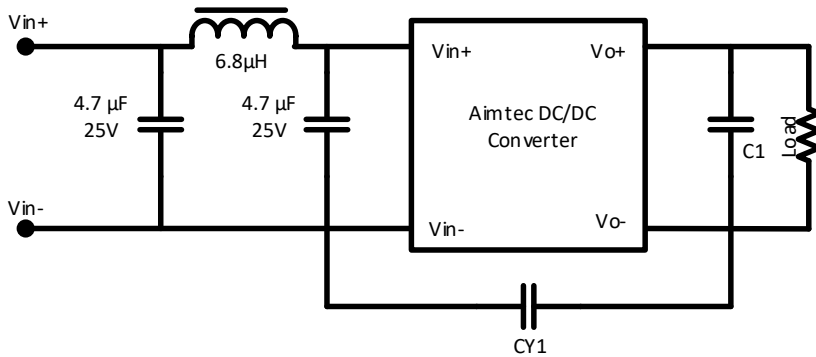

Output voltage	C1	CY1
3.3 V	10µF	N/C
5 V	10µF	
9 V	4.7µF	
12 V	2.2µF	1nF / 4KVDC for 3KV isolation 1nF / 2KVDC for 1.5KV isolation
15 V	1µF	
24V	0.47µF	

Dimensions

Dimensions for 1500VDC isolated models

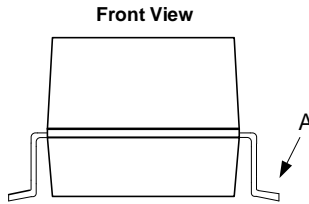
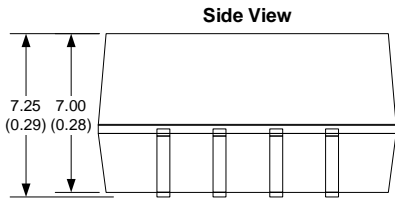

Pin Out Specifications	
Pin	Single
1	-V Input
2	+V Input
4	-V Output
5	+V Output
Other Pins	NC

NC: Pin to be isolated from circuitry

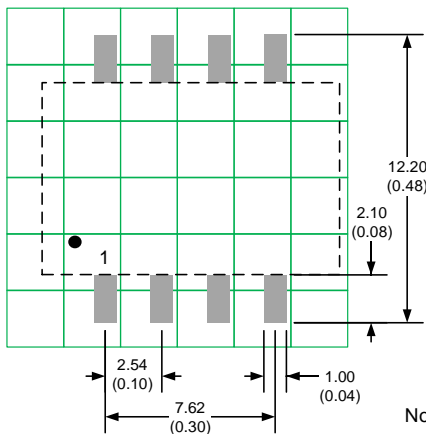
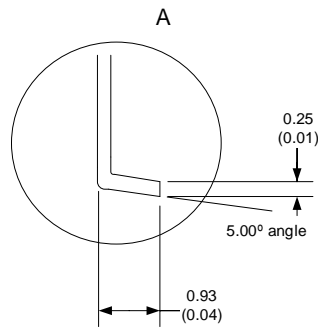
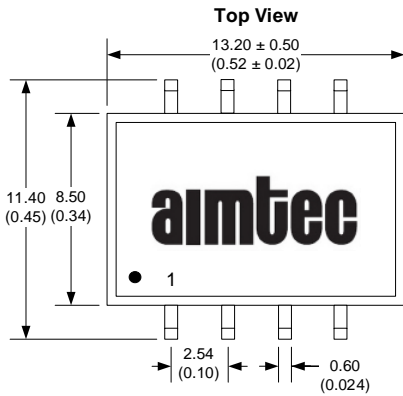

Notes:
All dimensions are typical in millimeters (inches).
Pin section tolerances : ± 0.10 (± 0.004)
General tolerances : ± 0.25 (± 0.01)

Note: Grid 2.54*2.54mm

Dimensions for 3000VDC isolated models

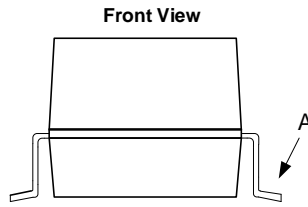
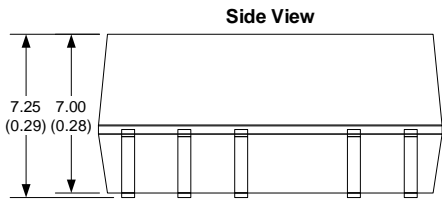

Pin Out Specifications		
Pin	Single	Dual
1	-V Input	-V Input
2	+V Input	+V Input
5	-V Output	Common
6	NC	-V Output
8	+V Output	+V Output
Other Pins	NC	NC

NC: Pin to be isolated from circuitry

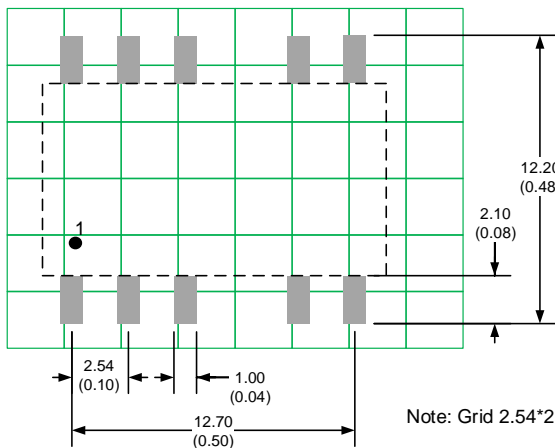
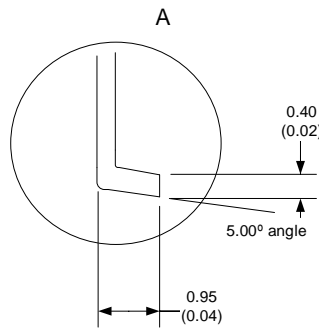
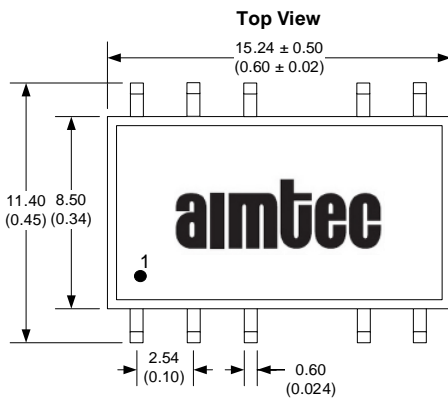

Notes:
All dimensions are typical in millimeters (inches).
Pin section tolerances : ± 0.10 (± 0.004)
General tolerances : ± 0.25 (± 0.01)

NOTE: 1. Datasheets are updated as needed and as such, specifications are subject to change without notice. Once printed or downloaded, datasheets are no longer controlled by Aimtec; refer to www.aimtec.com for the most current product specifications. **2.** Product labels shown, including safety agency certifications on labels, may vary based on the date manufactured. **3.** Mechanical drawings and specifications are for reference only. **4.** All specifications are measured at an ambient temperature of 25°C, humidity<75%, nominal input voltage and at rated output load unless otherwise specified. **5.** Aimtec may not have conducted destructive testing or chemical analysis on all internal components and chemicals at the time of publishing this document. CAS numbers and other limited information are considered proprietary and may not be available for release. **6.** This product is not designed for use in critical life support systems, equipment used in hazardous environments, nuclear control systems or other such applications which necessitate specific safety and regulatory standards other the ones listed in this datasheet. **7.** Warranty is in accordance with Aimtec's standard Terms of Sale available at www.aimtec.com.