

FEATURES

- Output Current up to 1A
- Low Dropout Voltage (1.2V at 1A Output current)
- Three Terminal Adjustable(ADJ) or Fixed 1.2V, 1.5V, 1.8V, 2.5V, 3.3V, 5.0V
- Line Regulation typically at 0.1% typ.
- Load Regulation typically at 0.2% typ.
- Internal Current and Terminal Protection
- Maximum Input Voltage 20V
- Surface Mount Package SOT-223, TO-252, SOT-89
- 100% Thermal Limit Burn-In
- Moisture Sensitivity Level 3

APPLICATION

- Active SCSI Terminators
- Portable/ Plan Top/ Notebook Computers
- High Efficiency Linear Regulators
- SMPS Post Regulators
- Mother B/D Clock Supplies
- Disk Drives
- Battery Chargers

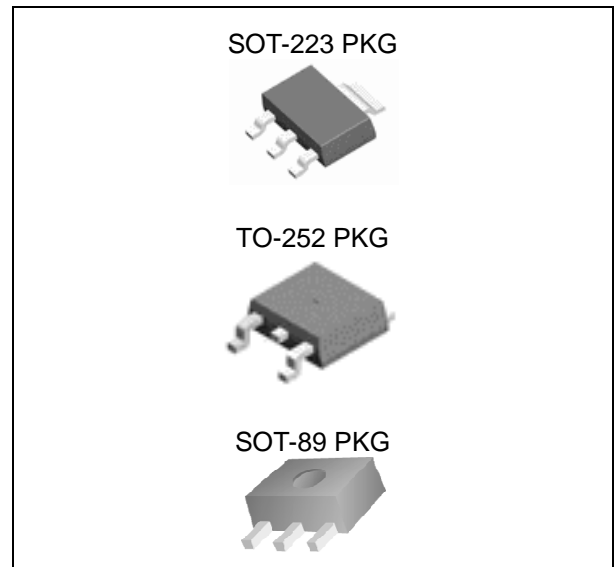

ORDERING INFORMATION

Device	Package
LM1117S-ADJ	SOT-223 3L
LM1117S-X.X	
LM1117GS-ADJ	
LM1117GS-X.X	
LM1117RS-ADJ	TO-252 3L
LM1117RS-X.X	
LM1117GRS-ADJ	
LM1117GRS-X.X	
LM1117F-ADJ	SOT-89 3L
LM1117F-X.X	
LM1117GF-ADJ	
LM1117GF-X.X	

X.X = Output Voltage = 1.2V, 1.5V, 1.8V, 2.5V, 3.3V, 5.0V

DESCRIPTION

The LM1117 is a low power positive-voltage regulator designed to meet 1A output current. This device is an excellent choice for use in battery-powered applications, as active terminators for the SCSI bus, and portable computers. The LM1117 features very low quiescent current and very low dropout voltage of 1.2V at a full load and lower as output current decreases. LM1117 is available as an adjustable or fixed 1.2V, 1.5V, 1.8V, 2.5V, 3.3V, and 5.0V output voltages. The LM1117 is offered in a 3-pin surface mount package SOT-223, TO-252 & SOT-89. The output capacitor of 10 μ F or larger is needed for output stability of LM1117 as required by most of the other regulator circuits.

ABSOLUTE MAXIMUM RATINGS

CHARACTERISTIC	SYMBOL	MIN.	MAX.	UNIT
Input Supply Voltage	V _{IN}	-	20	V
Lead Temperature	T _{SOL}	-	260	°C
Storage Temperature Range	T _{STG}	-65	150	°C
Operating Junction Temperature Range	T _{OPR}	-40	125	°C

ORDERING INFORMATION

V _{OUT}	Package	Order No.	Package Marking	Supplied As	Status
ADJ	SOT-223	LM1117S-ADJ	1117C ADJ	Reel	Active
	SOT-223	LM1117GS-ADJ	1117GC ADJ	Reel	Active
	TO-252	LM1117RS-ADJ	LM1117C ADJ	Reel	Active
	TO-252	LM1117GRS-ADJ	LM1117GC ADJ	Reel	Contact us
	SOT-89	LM1117F-ADJ	1117C ADJ	Reel	Active
	SOT-89	LM1117GF-ADJ	1117GC ADJ	Reel	Active
1.2V	SOT-223	LM1117S-1.2	1117C 1.2	Reel	Active
	SOT-223	LM1117GS-1.2	1117GC 1.2	Reel	Active
	TO-252	LM1117RS-1.2	LM1117C 1.2	Reel	Active
	TO-252	LM1117GRS-1.2	LM1117GC 1.2	Reel	Contact us
	SOT-89	LM1117F-1.2	1117C 1.2	Reel	Active
	SOT-89	LM1117GF-1.2	1117GC 1.2	Reel	Active
1.5V	SOT-223	LM1117S-1.5	1117C 1.5	Reel	Active
	SOT-223	LM1117GS-1.5	1117GC 1.5	Reel	Contact us
	TO-252	LM1117RS-1.5	LM1117C 1.5	Reel	Active
	TO-252	LM1117GRS-1.5	LM1117GC 1.5	Reel	Contact us
	SOT-89	LM1117F-1.5	1117C 1.5	Reel	Active
	SOT-89	LM1117GF-1.5	1117GC 1.5	Reel	Active
1.8V	SOT-223	LM1117S-1.8	1117C 1.8	Reel	Active
	SOT-223	LM1117GS-1.8	1117GC 1.8	Reel	Active
	TO-252	LM1117RS-1.8	LM1117C 1.8	Reel	Active
	TO-252	LM1117GRS-1.8	LM1117GC 1.8	Reel	Contact us
	SOT-89	LM1117F-1.8	1117C 1.8	Reel	Active
	SOT-89	LM1117GF-1.8	1117GC 1.8	Reel	Active
2.5V	SOT-223	LM1117S-2.5	1117C 2.5	Reel	Active
	SOT-223	LM1117GS-2.5	1117GC 2.5	Reel	Contact us
	TO-252	LM1117RS-2.5	LM1117C 2.5	Reel	Active
	TO-252	LM1117GRS-2.5	LM1117GC 2.5	Reel	Contact us
	SOT-89	LM1117F-2.5	1117C 2.5	Reel	Active
	SOT-89	LM1117GF-2.5	1117GC 2.5	Reel	Active
3.3V	SOT-223	LM1117S-3.3	1117C 3.3	Reel	Active
	SOT-223	LM1117GS-3.3	1117GC 3.3	Reel	Active
	TO-252	LM1117RS-3.3	LM1117C 3.3	Reel	Active
	TO-252	LM1117GRS-3.3	LM1117GC 3.3	Reel	Contact us
	SOT-89	LM1117F-3.3	1117C 3.3	Reel	Active
	SOT-89	LM1117GF-3.3	1117GC 3.3	Reel	Active

1A L.D.O VOLTAGE REGULATOR

LM1117

ORDERING INFORMATION

(Continued)

VOUT	Package	Order No.	Package Marking	Supplied As	Status
5.0V	SOT-223	LM1117S-5.0	1117C 5.0	Reel	Active
	SOT-223	LM1117GS-5.0	1117GC 5.0	Reel	Active
	TO-252	LM1117RS-5.0	LM1117C 5.0	Reel	Active
	TO-252	LM1117GRS-5.0	LM1117GC 5.0	Reel	Contact us
	SOT-89	LM1117F-5.0	1117C 5.0	Reel	Active
	SOT-89	LM1117GF-5.0	1117GC 5.0	Reel	Active

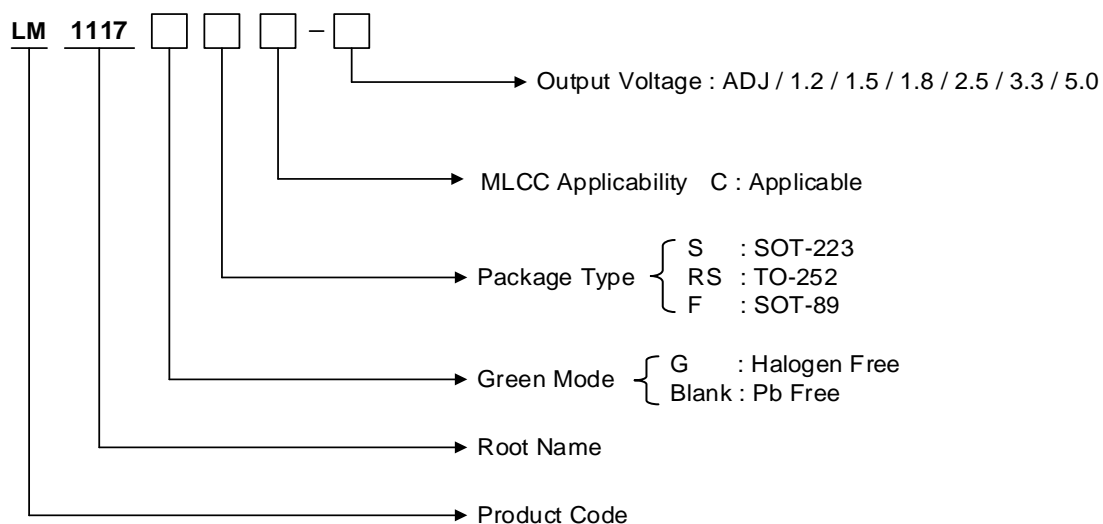

PIN CONFIGURATION

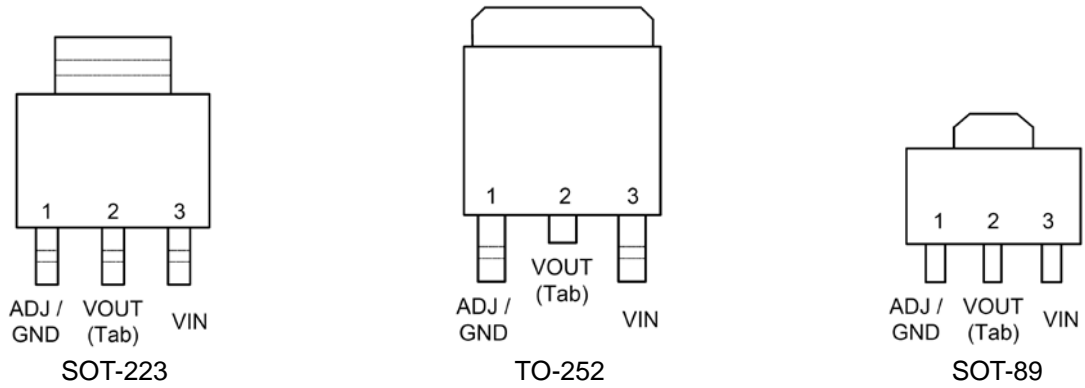

PIN DESCRIPTION

Pin No.	SOT-223 / TO-252 / SOT-89	
	Name	Function
1	ADJ/GND	Adjustable / Ground
2	V _{OUT}	Output Voltage
3	V _{IN}	Input Voltage

TYPICAL CIRCUIT

- V_{OUT}=Fixed version

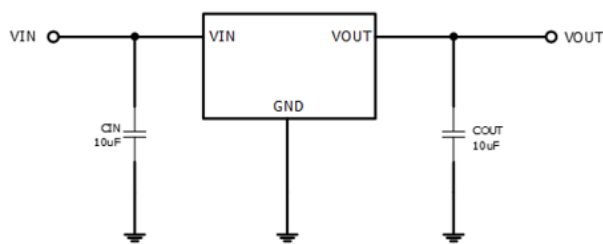

- V_{OUT}=Adjustable version

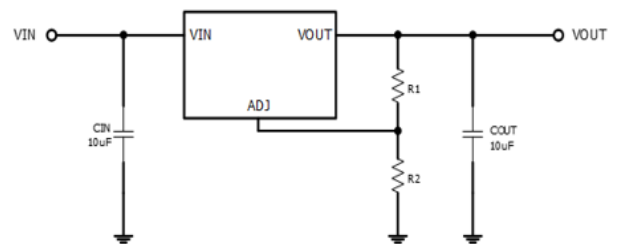

ELECTRICAL CHARACTERISTICS

For ADJ Output Voltage

($T_J=25^\circ\text{C}$, $C_{OUT} = 10\mu\text{F}$ unless otherwise specified)

Symbol	Parameters	Condition	Min.	Typ.	Max.	Unit
V_{REF}	Reference Voltage	$V_{IN} = 5\text{V}$, $I_O = 10\text{mA}$	1.238	1.250	1.262	V
V_{REF}	Reference Voltage	$I_O = 10\text{mA}$ to 1A , $V_{IN} - V_{REF} = 1.5\text{V}$ to 13.75V ($T_J = 0 \sim 125^\circ\text{C}$)	1.219		1.281	V
ΔV_{LINE}	Line Regulation	$I_O = 10\text{mA}$, $V_{IN} - V_{REF} = 1.5\text{V}$ to 12V		0.1	0.2	%
ΔV_{LOAD}	Load Regulation	$I_O = 10\text{mA}$ to 1A , $V_{IN} - V_{REF} = 2\text{V}$		0.2	0.4	%
V_{IN}	Operating Input Voltage				12	V
I_{ADJ}	Adjustment pin Current	$V_{IN} - V_{REF} = 1.5\text{V}$ to 12V , $I_O = 100\text{mA}$		50	120	μA
ΔI_{ADJ}	Adjustment Pin Current Change	$V_{IN} - V_{REF} = 1.5\text{V}$ to 12V , $I_O = 100\text{mA}$ to 1A		0.5	5	μA
$I_{O(MIN)}$	Minimum Load Current	$V_{IN} = 5\text{V}$, $V_{REF} = 0\text{V}$		5	10	mA
I_O	Current Limit	$V_{IN} - V_{REF} = 5\text{V}$	1000			mA
ϵ_N	Output Noise(% V_O)	$B = 10\text{Hz}$ to 10kHz , $T_J = 25^\circ\text{C}$		0.003		%
SVR	Supply Voltage Rejection	$I_O = 1\text{A}$, $f = 120\text{Hz}$, $V_{IN} - V_{REF} = 3\text{V}$, $V_{RIPPLE} = 1\text{V}_{PP}$	60	75		dB

For 1.2V Output Voltage

($T_J=25^\circ\text{C}$, $C_{OUT} = 10\mu\text{F}$ unless otherwise specified)

Symbol	Parameters	Condition	Min.	Typ.	Max.	Unit
V_O	Output Voltage	$V_{IN} = 2.7\text{V}$, $I_O = 10\text{mA}$	1.176	1.200	1.224	V
V_O	Output Voltage	$V_{IN} = 2.7\text{V}$ to 12V , $I_O = 0\text{mA}$ to 1A ($T_J = 0 \sim 125^\circ\text{C}$)	1.152		1.248	V
ΔV_{LINE}	Line Regulation	$I_O = 10\text{mA}$, $V_{IN} = 2.7\text{V}$ to 12V		0.1	0.2	%
ΔV_{LOAD}	Load Regulation	$I_O = 10\text{mA}$ to 1A , $V_{IN} = 3.2\text{V}$		0.2	0.4	%
V_{IN}	Operating Input Voltage				12	V
I_D	Quiescent Current	$V_{IN} - V_O = 5\text{V}$		5	10	mA
I_O	Current Limit	$V_{IN} - V_O = 5\text{V}$	1000			mA
ϵ_N	Output Noise(% V_O)	$B = 10\text{Hz}$ to 10kHz , $T_J = 25^\circ\text{C}$		0.003		%
SVR	Supply Voltage Rejection	$I_O = 1\text{A}$, $f = 120\text{Hz}$, $V_{IN} - V_O = 1.5\text{V}$, $V_{RIPPLE} = 1\text{V}_{PP}$	60	75		dB

1A L.D.O VOLTAGE REGULATOR

LM1117

For 1.5V Output Voltage

($T_J=25^\circ\text{C}$, $C_{OUT} = 10\mu\text{F}$ unless otherwise specified)

Symbol	Parameters	Condition	Min.	Typ.	Max.	Unit
V_O	Output Voltage	$V_{IN} = 3.0\text{V}$, $I_O = 10\text{mA}$	1.485	1.5	1.515	V
V_O	Output Voltage	$V_{IN} = 3.0\text{V to } 12\text{V}$, $I_O = 0\text{mA to } 1\text{A}$ ($T_J = 0 \sim 125^\circ\text{C}$)	1.470		1.530	V
ΔV_{LINE}	Line Regulation	$I_O = 10\text{mA}$, $V_{IN} = 3.0\text{V to } 12\text{V}$		0.1	0.2	%
ΔV_{LOAD}	Load Regulation	$I_O = 10\text{mA to } 1\text{A}$, $V_{IN} = 3.5\text{V}$		0.2	0.4	%
V_{IN}	Operating Input Voltage				12	V
I_D	Quiescent Current	$V_{IN} - V_O = 5\text{V}$		5	10	mA
I_O	Current Limit	$V_{IN} - V_O = 5\text{V}$	1000			mA
e_N	Output Noise(% V_O)	$B = 10\text{Hz to } 10\text{kHz}$, $T_J = 25^\circ\text{C}$		100		μV
SVR	Supply Voltage Rejection	$I_O = 1\text{A}$, $f = 120\text{Hz}$, $V_{IN} - V_O = 3\text{V}$, $V_{RIPPLE} = 1\text{V}_{PP}$	60	75		dB

For 1.8V Output Voltage

($T_J=25^\circ\text{C}$, $C_{OUT} = 10\mu\text{F}$ unless otherwise specified)

Symbol	Parameters	Condition	Min.	Typ.	Max.	Unit
V_O	Output Voltage	$V_{IN} = 3.3\text{V}$, $I_O = 10\text{mA}$	1.782	1.8	1.818	V
V_O	Output Voltage	$V_{IN} = 3.3\text{V to } 12\text{V}$, $I_O = 0\text{mA to } 1\text{A}$ ($T_J = 0 \sim 125^\circ\text{C}$)	1.764		1.836	V
ΔV_{LINE}	Line Regulation	$I_O = 10\text{mA}$, $V_{IN} = 3.3\text{V to } 12\text{V}$		0.1	0.2	%
ΔV_{LOAD}	Load Regulation	$I_O = 10\text{mA to } 1\text{A}$, $V_{IN} = 3.8\text{V}$		0.2	0.4	%
V_{IN}	Operating Input Voltage				12	V
I_D	Quiescent Current	$V_{IN} - V_O = 5\text{V}$		5	10	mA
I_O	Current Limit	$V_{IN} - V_O = 5\text{V}$	1000			mA
e_N	Output Noise(% V_O)	$B = 10\text{Hz to } 10\text{kHz}$, $T_J = 25^\circ\text{C}$		100		μV
SVR	Supply Voltage Rejection	$I_O = 1\text{A}$, $f = 120\text{Hz}$, $V_{IN} - V_O = 3\text{V}$, $V_{RIPPLE} = 1\text{V}_{PP}$	60	75		dB

1A L.D.O VOLTAGE REGULATOR

LM1117

For 2.5V Output Voltage

($T_J=25^\circ\text{C}$, $C_{OUT} = 10\mu\text{F}$ unless otherwise specified)

Symbol	Parameters	Condition	Min.	Typ.	Max.	Unit
V_O	Output Voltage	$V_{IN} = 4.0\text{V}$, $I_O = 10\text{mA}$	2.475	2.5	2.525	V
V_O	Output Voltage	$V_{IN} = 4.0\text{V}$ to 12V , $I_O = 0\text{mA}$ to 1A ($T_J = 0 \sim 125^\circ\text{C}$)	2.450		2.550	V
ΔV_{LINE}	Line Regulation	$I_O = 10\text{mA}$, $V_{IN} = 4.0\text{V}$ to 12V		0.1	0.2	%
ΔV_{LOAD}	Load Regulation	$I_O = 10\text{mA}$ to 1A , $V_{IN} = 4.5\text{V}$		0.2	0.4	%
V_{IN}	Operating Input Voltage				12	V
I_D	Quiescent Current	$V_{IN} - V_O = 5\text{V}$		5	10	mA
I_O	Current Limit	$V_{IN} - V_O = 5\text{V}$	1000			mA
e_N	Output Noise(% V_O)	$B = 10\text{Hz}$ to 10kHz , $T_J = 25^\circ\text{C}$		100		μV
SVR	Supply Voltage Rejection	$I_O = 1\text{A}$, $f = 120\text{Hz}$, $V_{IN} - V_O = 3\text{V}$, $V_{RIPPLE} = 1\text{V}_{PP}$	60	75		dB

For 3.3V Output Voltage

($T_J=25^\circ\text{C}$, $C_{OUT} = 10\mu\text{F}$ unless otherwise specified)

Symbol	Parameters	Condition	Min.	Typ.	Max.	Unit
V_O	Output Voltage	$V_{IN} = 4.8\text{V}$, $I_O = 10\text{mA}$	3.267	3.3	3.333	V
V_O	Output Voltage	$V_{IN} = 4.8\text{V}$ to 12V , $I_O = 0\text{mA}$ to 1A ($T_J = 0 \sim 125^\circ\text{C}$)	3.234		3.366	V
ΔV_{LINE}	Line Regulation	$I_O = 10\text{mA}$, $V_{IN} = 4.8\text{V}$ to 12V		0.1	0.2	%
ΔV_{LOAD}	Load Regulation	$I_O = 10\text{mA}$ to 1A , $V_{IN} = 5.3\text{V}$		0.2	0.4	%
V_{IN}	Operating Input Voltage				12	V
I_D	Quiescent Current	$V_{IN} - V_O = 5\text{V}$		5	10	mA
I_O	Current Limit	$V_{IN} - V_O = 5\text{V}$	1000			mA
e_N	Output Noise(% V_O)	$B = 10\text{Hz}$ to 10kHz , $T_J = 25^\circ\text{C}$		100		μV
SVR	Supply Voltage Rejection	$I_O = 1\text{A}$, $f = 120\text{Hz}$, $V_{IN} - V_O = 3\text{V}$, $V_{RIPPLE} = 1\text{V}_{PP}$	60	75		dB

1A L.D.O VOLTAGE REGULATOR

LM1117

For 5.0V Output Voltage

($T_J=25^\circ\text{C}$, $C_{OUT} = 10\mu\text{F}$ unless otherwise specified)

Symbol	Parameters	Condition	Min.	Typ.	Max.	Unit
V_O	Output Voltage	$V_{IN} = 6.5\text{V}$, $I_O = 10\text{mA}$	4.950	5.0	5.050	V
V_O	Output Voltage	$V_{IN} = 6.5\text{V}$ to 15V , $I_O = 0\text{mA}$ to 1A ($T_J = 0 \sim 125^\circ\text{C}$)	4.900		5.100	V
ΔV_{LINE}	Line Regulation	$I_O = 10\text{mA}$, $V_{IN} = 6.5\text{V}$ to 15V		0.1	0.2	%
ΔV_{LOAD}	Load Regulation	$I_O = 10\text{mA}$ to 1A , $V_{IN} = 7.0\text{V}$		0.2	0.4	%
V_{IN}	Operating Input Voltage				12	V
I_D	Quiescent Current	$V_{IN} - V_O = 5\text{V}$		5	10	mA
I_O	Current Limit	$V_{IN} - V_O = 5\text{V}$	1000			mA
ϵ_N	Output Noise(% V_O)	$B = 10\text{Hz}$ to 10kHz , $T_J = 25^\circ\text{C}$		100		μV
SVR	Supply Voltage Rejection	$I_O = 1\text{A}$, $f = 120\text{Hz}$, $V_{IN} - V_O = 3\text{V}$, $V_{RIPPLE} = 1\text{V}_{PP}$	60	75		dB

For All Output Voltage

($T_J=25^\circ\text{C}$, $C_{OUT} = 10\mu\text{F}$ unless otherwise specified)

Symbol	Parameters	Condition	Min.	Typ.	Max.	Unit
V_D	Dropout Voltage	$I_O = 100\text{mA}$		1.0	1.1	V
		$I_O = 500\text{mA}$		1.1	1.2	V
		$I_O = 1\text{A}$		1.2	1.3	V
	Temperature Stability			0.5		%
	Long Term Stability	1000 hrs, $T_J = 125^\circ\text{C}$		0.3		%
	Thermal Regulation	$T_A = 25^\circ\text{C}$ 30ms Pulse		0.003		%/W

TYPICAL APPLICATION CIRCUIT

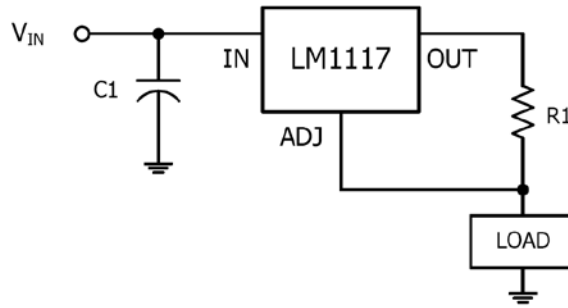

Fig.1 1A Current Output

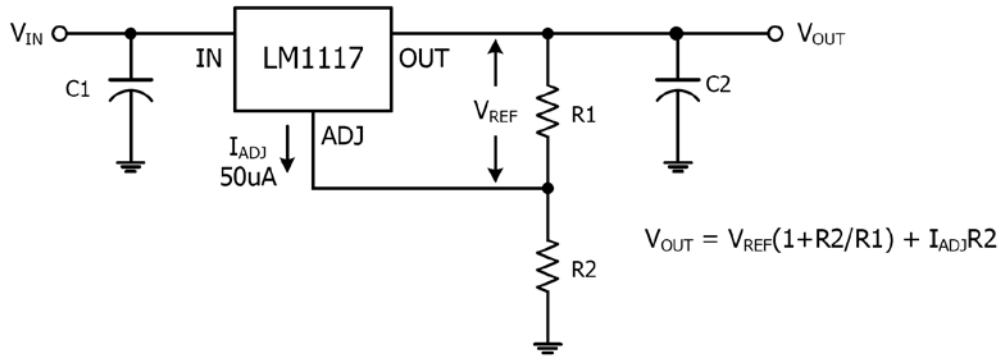

Fig.2 Typical Adjustable Regulator

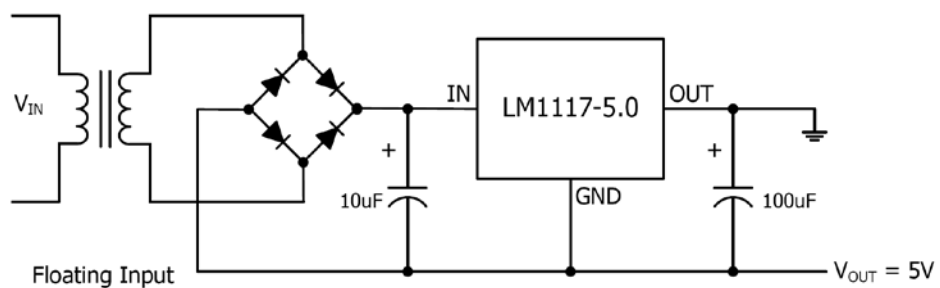

Fig.3 Negative Supply

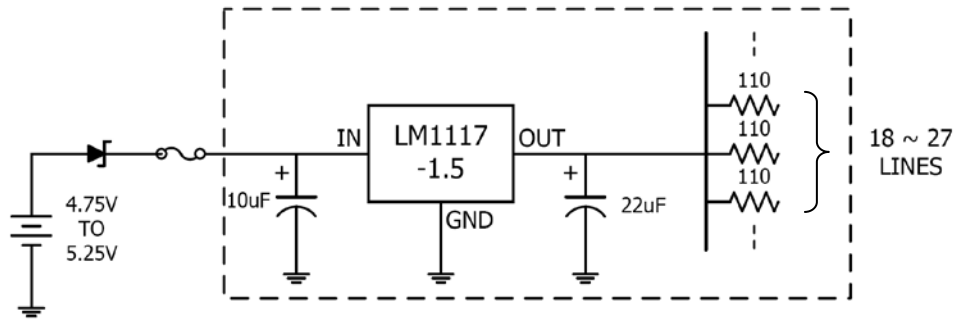

Fig.4 Active Terminator for SCSI-2BUS

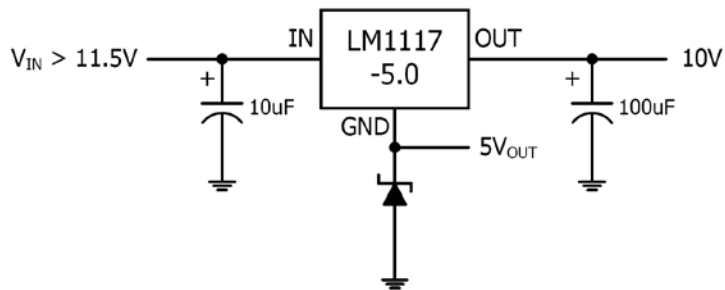

Fig.5 Voltage Regulator with Reference

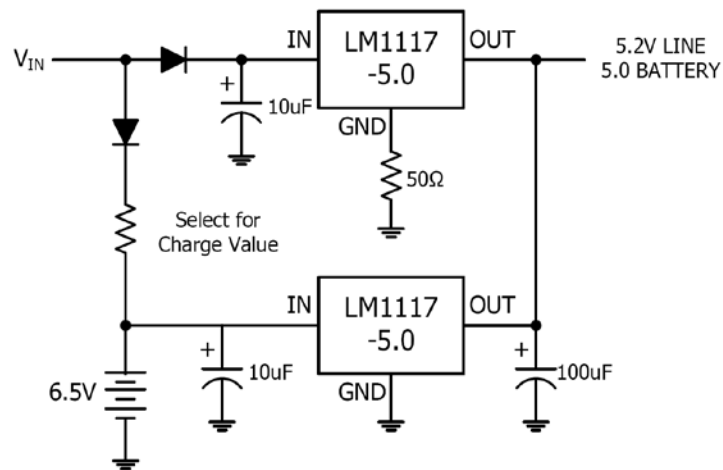

Fig.6 Battery Backed-up Regulated Supply

TYPICAL OPERATING CHARACTERISTICS

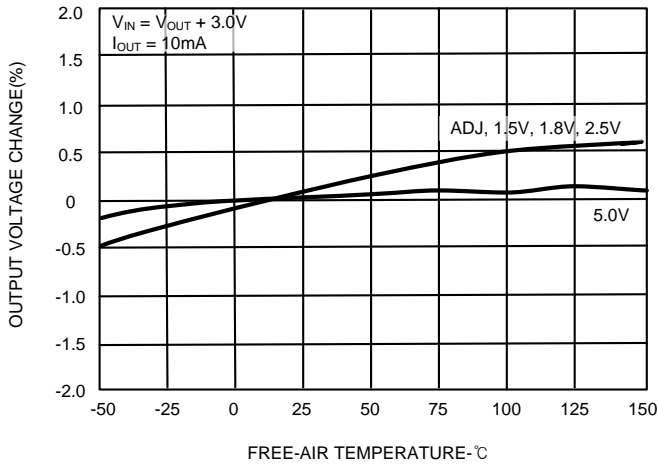

Fig.7 OUTPUT VOLTAGE CHANGE VS TEMPERATURE

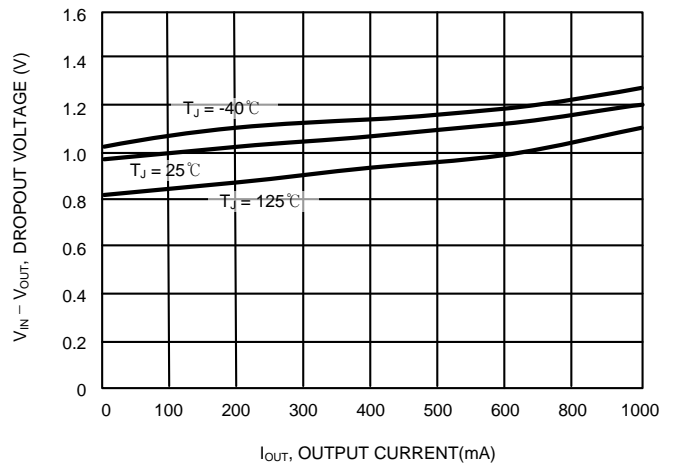

Fig.8 DROPOUT VOLTAGE VS OUTPUT CURRENT

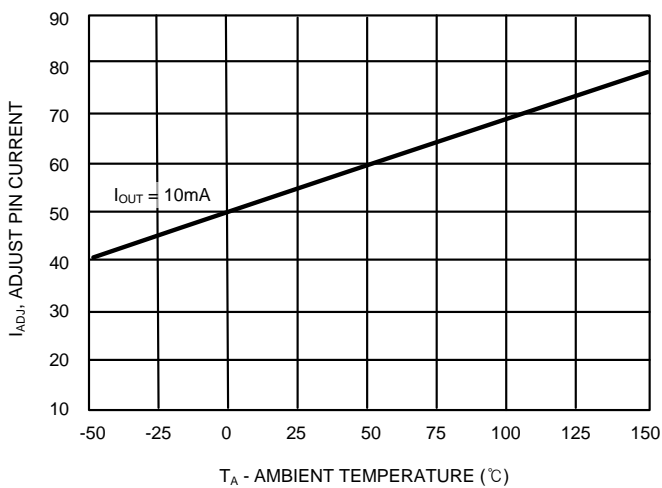

Fig.9 ADJ PIN CURRENT VS TEMPERATURE

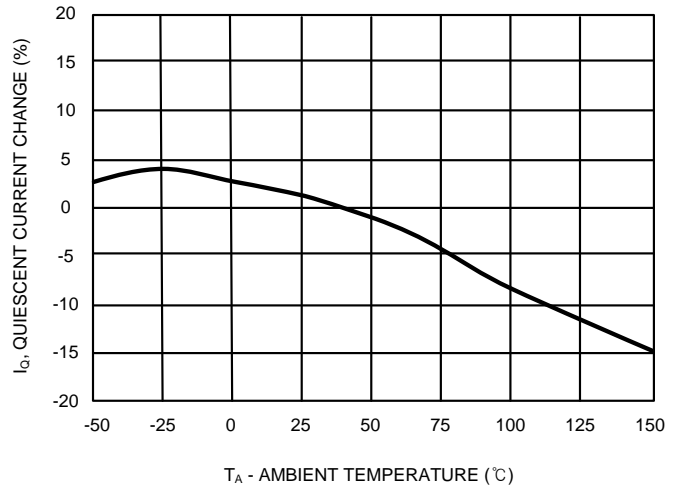

Fig.10 QUIESCENT CURRENT CHANGE VS TEMPERATURE

APPLICATION INFORMATION

Maximum Output Current Capability

The LM1117 can deliver a continuous current of 1A over the full operating junction temperature range. However, the output current is limited by the restriction of power dissipation which differs from packages. A heat sink may be required depending on the maximum power dissipation and maximum ambient temperature of application. With respect to the applied package, the maximum output current of 1A may be still undeliverable due to the restriction of the power dissipation of LM1117. Under all possible conditions, the junction temperature must be within the range specified under operating conditions. The temperatures over the device are given by:

$$T_C = T_A + P_D \times \theta_{CA} \quad / \quad T_J = T_C + P_D \times \theta_{JC} \quad / \quad T_J = T_A + P_D \times \theta_{JA}$$

where T_J is the junction temperature, T_C is the case temperature, T_A is the ambient temperature, P_D is the total power dissipation of the device, θ_{CA} is the thermal resistance of case-to-ambient, θ_{JC} is the thermal resistance of junction-to-case, and θ_{JA} is the thermal resistance of junction to ambient. The total power dissipation of the device is given by:

$$P_D = P_{IN} - P_{OUT} = (V_{IN} \times I_{IN}) - (V_{OUT} \times I_{OUT}) \\ = (V_{IN} \times (I_{OUT} + I_{GND})) - (V_{OUT} \times I_{OUT}) = (V_{IN} - V_{OUT}) \times I_{OUT} + (V_{IN} \times I_{GND})$$

where I_{GND} is the operating ground current of the device which is specified at the Electrical Characteristics. The maximum allowable temperature rise (T_{Rmax}) depends on the maximum ambient temperature (T_{Amax}) of the application, and the maximum allowable junction temperature (T_{Jmax}):

$$T_{Rmax} = T_{Jmax} - T_{Amax}$$

The maximum allowable value for junction-to-ambient thermal resistance, θ_{JA} , can be calculated using the formula:

$$\theta_{JA} = T_{Rmax} / P_D = (T_{Jmax} - T_{Amax}) / P_D$$

LM1117 is available in SOT223, TO252 and SOT89 packages. The thermal resistance depends on amount of copper area or heat sink, and on air flow. If the maximum allowable value of θ_{JA} calculated above is over 137°C/W for SOT-223 package, over 105 °C/W for TO252 package, over 315 °C/W for SOT-89 package, no heat sink is needed since the package can dissipate enough heat to satisfy these requirements. If the value for allowable θ_{JA} falls near or below these limits, a heat sink or proper area of copper plane is required. In summary, the absolute maximum ratings of thermal resistances are as follow:

Absolute Maximum Ratings of Thermal Resistance

Characteristic	Symbol	Rating	Unit
Thermal Resistance Junction-To-Ambient / SOT-223	$\theta_{JA-SOT-223}$	137	°C/W
Thermal Resistance Junction-To-Ambient / TO-252	$\theta_{JA-TO-252}$	105	°C/W
Thermal Resistance Junction-To-Ambient / SOT-89	$\theta_{JA-SOT-89}$	315	°C/W

No heat sink / No air flow / No adjacent heat source / $T_A=25^\circ\text{C}$

REVISION NOTICE

The description in this datasheet can be revised without any notice to describe its electrical characteristics properly.