

## Polarized monostable safety relay with forcibly guided double contacts

# SF4D RELAY

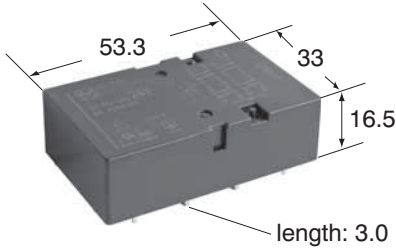

Tolerance  $\pm 0.3\text{mm}$   
Weight approx. 47g

## FEATURES

- Relay complies with IEC 61810-3, Type B and with IEC/EN 60335-1 (GWT)
- Overvoltage category as per IEC 60664-1 III / 4kV
- Rated voltage as per IEC 60664-1 basic insulation

		Pollution degree		
		2 inside	2 outside	3 inside
Coil-contact		400V	400V	250V
Contact-contact	forcibly linked pair only	250V	250V	250V
	all other contacts	400V	400V	400V

## SPECIFICATIONS

### Contact

Contact configuration (a = normally open / NO, b = normally closed / NC)	4a4b
Contact material	AgSnO <sub>2</sub> , with Au flash
Contact resistance (initial at 6V DC, 1A)	$\leq 30\text{m}\Omega$
Making and breaking capacities (breathing hole open) <sup>*1</sup>	6A 250V / 3A 24V
Max. switching voltage	400V
Min. switching voltage / min. switching current	10V / 10mA
Pick-up / drop-out / bounce time (approx. values at U <sub>nominal</sub> )	18.5 / 7.5 / 3ms
Mechanical life	10 <sup>7</sup> ops

### Coil

Operate / release voltage (% of U <sub>nominal</sub> at 20°C)	75% / 15%
Pick-up/nominal power consumption at 20°C	280 / 500mW

### Remarks:

- \*1 According to EN 60947-5-1: 1997, table 4 AC15 / DC13  
\*2 Contact interruption <10 $\mu\text{s}$   
\*3 Breathing hole open

### Characteristics

Max. switching frequency (without load)	10Hz
Permissible ambient temperature at nominal power consumption	-40°C to +70°C
Upper temperature limit	105°C
Test voltage: open contact / contact-contact / contact-coil	2500 / 2500 / 2500V <sub>rms</sub>
Insulation resistance at 500V DC (initial)	10 <sup>9</sup> $\Omega$
Shock resistance (11ms) NO/NC <sup>*2</sup>	30G
Vibration resistance 10 – 200 Hz (10 – 55 Hz, amplitude 2 mm) <sup>*2</sup>	10G
Degree of protection	IP67 / IP30 <sup>*3</sup>
Unit weight	47g

### Important: Relay characteristics may be influenced by:

- strong external magnetic fields
- magnetic conductive materials near the relay
- narrow top-to-top mounting (printed surface to printed surface)

### Note:

Suitable for most common washing methods except ultrasonic cleaning.

## ORDERING INFORMATION

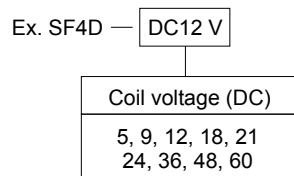

Note: Standard packing; Carton: 20 pcs. Case 200 pcs.

## COIL DATA

Part number	Coil nominal voltage V DC	Operate voltage V DC	Release voltage V DC	Coil resistance $\Omega$ ( $\pm 10\%$ , $20^\circ\text{C}$ )	Coil inductance (mH)
SF4D-DC5V	5	3.75	0.75	50	47
SF4D-DC9V	9	6.75	1.35	162	145
SF4D-DC12V	12	9.00	1.80	288	252
SF4D-DC18V	18	13.50	2.70	648	551
SF4D-DC21V	21	15.75	3.15	882	742
SF4D-DC24V	24	18.00	3.60	1152	959
SF4D-DC36V	36	27.00	5.40	2592	2097
SF4D-DC48V	48	36.00	7.20	4608	3654
SF4D-DC60V	60	45.00	9.00	7200	5612

## ELECTRICAL LIFE

Voltage	Current	Load type	Frequency	Duty cycle	No. of contacts	No. of ops.
230V AC	8A	AC 1	0.25Hz	25%	4 <sup>*2</sup>	85,000 <sup>*5</sup>
250V AC	6A	AC 1	0.33Hz	50%	4 <sup>*2</sup> / 8 <sup>*3</sup>	100,000 <sup>*5</sup>
230V AC	6A	AC 1	0.33Hz	10%	2 <sup>*3</sup>	200,000 <sup>*4,*5</sup>
230V AC	30 / 3A	AC 15 <sup>*1</sup>	0.33Hz	10%	1 <sup>*3</sup>	200,000 <sup>*4,*5</sup>
24V DC	8A	DC 1	0.33Hz	10%	2 <sup>*3</sup>	200,000 <sup>*4,*5</sup>
24V DC	3A	DC 13 <sup>*1</sup>	0.33Hz	10%	1 <sup>*3</sup>	50,000 <sup>*4,*5</sup>
24V DC	3A	L/R = 40ms	0.33Hz	10%	1 <sup>*3</sup>	100,000 <sup>*4,*5</sup>

\*1 EN 60947-5-1: 1997; table C.1

\*2 Breathing hole closed

\*3 Breathing hole open

\*4 Ambient temperature  $+70^\circ\text{C}$

\*5 Dielectric strength according to EN61810-1:2004.

## REFERENCE DATA

Load limit curve

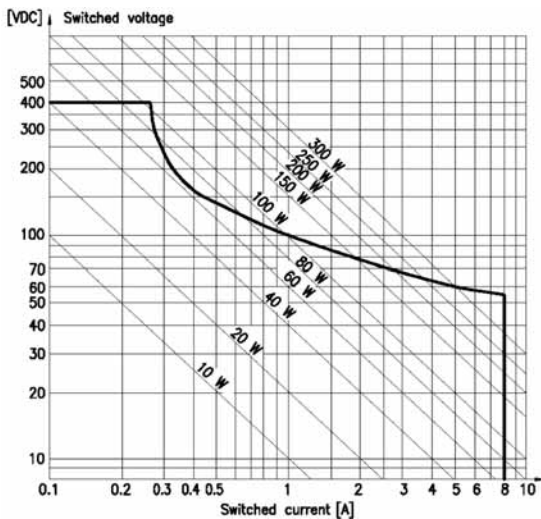

Loads in the range under the curve can be switched safely. The arc will extinguish before the opposite contact makes.

Coil voltage characteristics

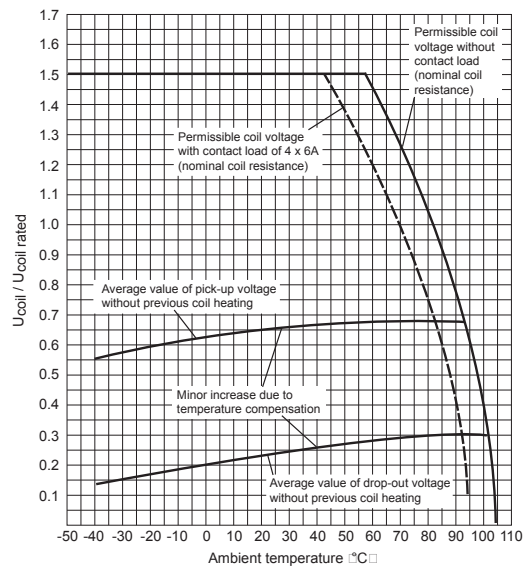

Permissible coil voltages and pick-up and drop-out characteristics at various ambient temperatures.

## Contact current characteristics

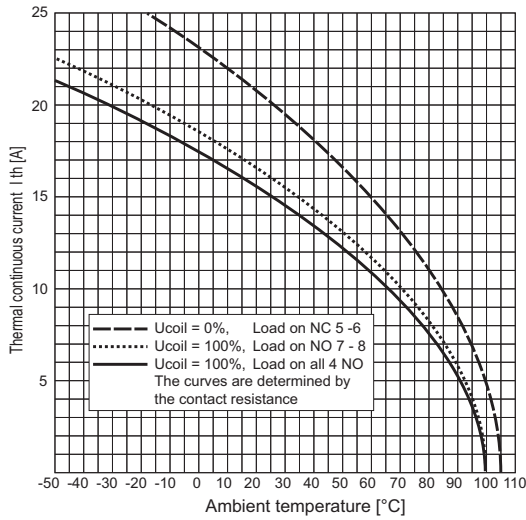

## DIMENSIONS (mm inch)

Download [CAD Data](#) from our Web site.

### 4 Form A 4 Form B

[CAD Data](#)



### External dimensions

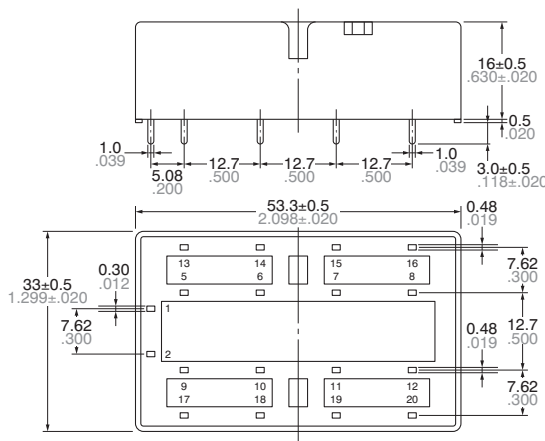

### Schematic (Bottom view)

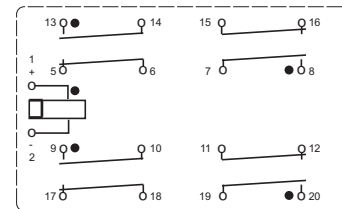

The contacts are shown in the deenergized condition.

### PC board pattern (Bottom view)

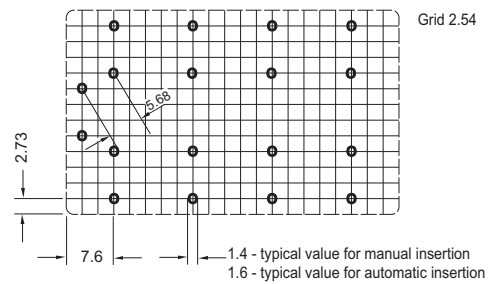

## APPLICATION NOTES

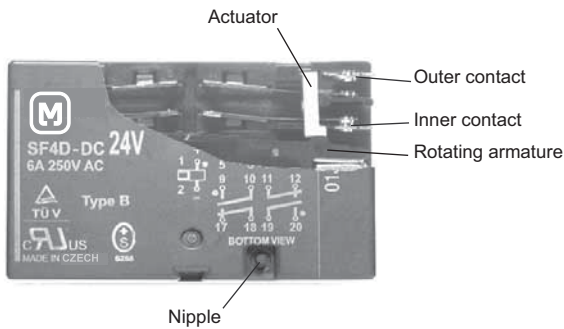

If required a breathing hole can be made in the cover by removing the nipple. However be aware that the degree of protection will be reduced from IP67 to IP30!

### Operation of forcibly guided contacts, Type B

**If an outer contact should weld**, then the forced operated inner contacts driven by the actuator remain open. The rotating armature remains free to move. The unaffected contact pairs can operate normally, i.e. their function to make or break remains unaffected.

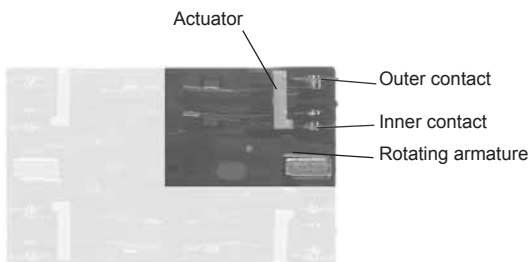

**If an inner contact should weld**, then the movement of the rotating armature is blocked via the actuator. Open contacts of all four contact pairs remain open. This arrangement corresponds to a conventional forcibly guided contact operation.

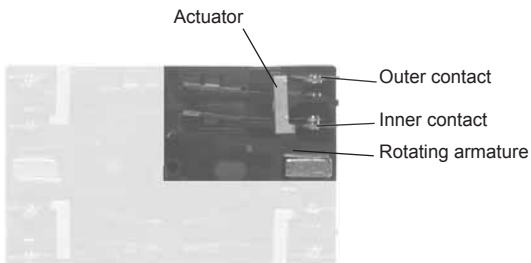

## SAFETY STANDARDS

UL/C-UL (Recognized)		TÜV (Certified)**	
File No.	Contact rating	File No.	Rating
E120782*	6A 250V AC	968 EZ 116.00 01 (SF2D)	8A 24V DC
	6A 24V DC	968 EZ 113.00 01 (SF4D)	6A 230V AC

\* CSA standard: Certified by C-UL

\*\* Test procedure A (Group Mounting)

## SAFETY STRUCTURE OF SF RELAYS

This SF relay design ensures that subsequent operations shut down and can automatically return to a safe state when the SF relay suffers overloading and other circuit abnormalities

(unforeseen externally caused circuit or device breakdowns, end of life incidents, and noise, surge, and environmental influences) owing to contact welding, spring fusion or, in the worst-case

scenario, relay breakdown (coil rupture, faulty operation, faulty return, and fatigue and breakage of the operating spring and return spring), and even in the event of end of life.

	Structure	Operation
1. Forced operation method (2 Form A 2 Form B, 4 Form A 4 Form B types)	<p>The two contacts "a" and "b" are coupled with the same card. The operation of each contact is regulated by the movement of the other contact.</p>	<p>Even when one contact is welded closed, the other maintains a gap of greater than 0.5 mm .020 inch.</p> <p>In the diagram on the left, the lower contact "b" have welded but the upper contact "a" maintain at a gap of greater than 0.5 mm .020 inch. Subsequent contact movement is suspended and the weld can be detected</p>
2. Independent operation method (4 Form A 4 Form B type)	<p>None of four contacts are held in position by the armature. Even though one of the external N.O. contacts has welded, the other three contacts have returned owing to the de-energizing of the coil.</p>	<p>Enables design of safety circuits that allow weld detection and return at an early stage.</p> <p>As shown at the top right of the diagram on the left, if the external N.O. contact welds, a 0.5 mm .020 inch gap is maintained. Each of the other contacts returns to N.O. because the coil is no longer energized.</p>
3. Separate chamber method (2 Form A 2 Form B, 4 Form A 4 Form B types)	<p>In independent chambers, the contacts "a" and "b" are kept apart by a body/ case separator or by the card itself.</p>	<p>Prevents shorting and fusing of springs and spring failure owing to short-circuit current.</p> <p>As shown on the diagram on the left, even if the operating springs numbered 1 and 2 there is no shorting between "a" and "b" contacts.</p>
4. 2 Form A 2 Form B contact 4 Form A 4 Form B contact	Structure with independent COM contact of 2 Form A 2 Form B and 4 Form A 4 Form B contacts.	Independent COM enables differing pole circuit configurations. This makes it possible to design various kinds of control circuits and safety circuits.

# THE OPERATION OF SF RELAYS (when contacts are welded)

SF relays work to maintain a normal operating state even when the contact welding occur by overloading or short-circuit currents. It is easy to make weld detection circuits and safety circuits in the design to ensure safety even if contacts weld.

## 4 Form A 4 Form B type

### Internal Contacts Weld

When internal contacts (No. 2, No. 3, No. 6 or No. 7) are welded, the armature becomes non-operational and the four form "a" contact gaps are maintained at 0.5 mm .020inch or greater. Reliable cut-off is thus ensured.

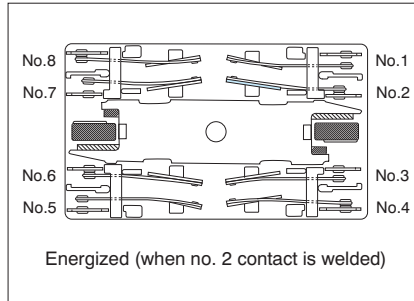
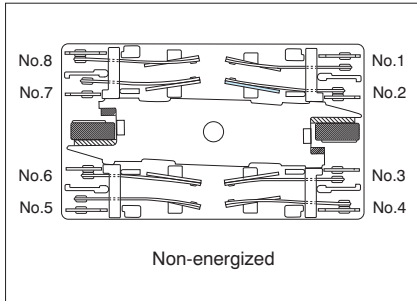

**Example: If the No. 2 contact welds.**  
Each of the four form "a" contacts (No. 1, 3, 5, and 7) maintains a gap of greater than 0.5 mm .020 inch.

### External Contacts Weld

When external contacts (No. 1, No. 4, No. 5 or No. 8) are welded, gaps of 0.5 mm .020inch and greater are maintained between adjacent contacts and other contacts operate normally by the coil being non-energized.

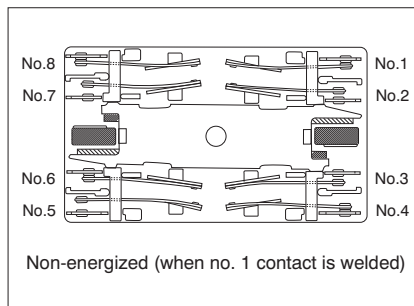
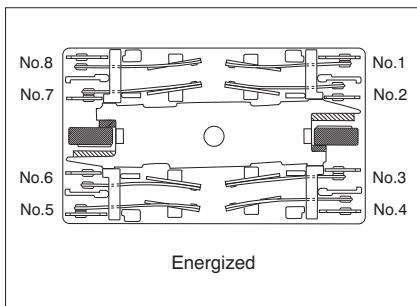

**Example 1: If the No. 1 contact welds.**  
The adjacent No. 2 contact maintains a gap of greater than 0.5 mm .020 inch. The other contacts, because the coil is not energized, return to their normal return state; each of form "a" contacts (No. 3, 5, and 7) maintains a contact gap of greater than 0.5 mm .020 inch; each of the form "b" contacts (No. 4, 6, and 8) return to a closed state.

**Example 2:**  
If external connections are made in series. Even if one of the contacts welds, the other contacts operate independently and the contact gaps are maintained at greater than 0.5 mm .020 inch.

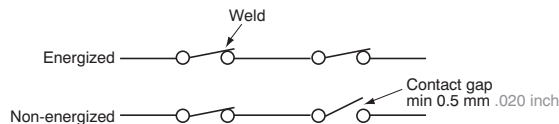

### Contact Operation Table

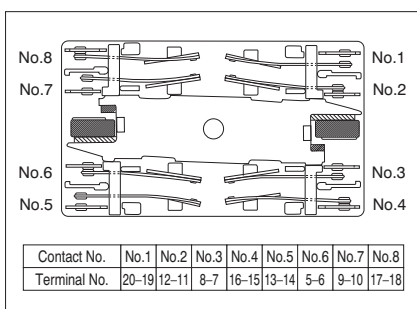

The table below shows the state of the other contacts when the current through the welded form "a" contact is 0 V and the rated voltage is applied through the form "b" contact.

Contact No.	State of other contacts							
	1	2	3	4	5	6	7	8
1		>0.5	>0.5		>0.5		>0.5	
2	>0.5		>0.5		>0.5		>0.5	
3		>0.5		>0.5		>0.5		>0.5
4		>0.5	>0.5			>0.5		>0.5
5	>0.5		>0.5			>0.5	>0.5	
6	>0.5		>0.5		>0.5		>0.5	
7		>0.5		>0.5		>0.5		>0.5
8	>0.5	>0.5		>0.5		>0.5	>0.5	

>0.5: contact gap is kept at min. 0.5 mm .020 inch  
|: contact closed  
Empty cells: either closed or open

\* Contact gaps are shown at the initial state.  
If the contacts change state owing to loading/breaking it is necessary to check the actual loading.

**For Cautions for Use, see Relay Technical Information.**