

Notes:

- * Insulation: Nylon 6T UL 94V-0, Color Black
- * Contact: Brass
- * Fixed Tabs: Brass with Matte Tin Plated
- * For Lead Free IR Reflow Process

Ordering Code:

CP35 ** P * H S T - NH
 ① ② ③ ④ ⑤ ⑥ ⑦ ⑧

- ① Series No.
- ② No. of Circuits: 02~24
- ③ Contact type: P= Plug
- ④ Contact plated:
 - 1= Matte Tin Plated over Nickel
 - A= Selective Gold Flash Plated on Contact area and Matte Tin Plating on Soldertails, 1.27?m(50?) Nickel Underplating over all
 - B= Selective 0.38?m(15?) Gold Plated on Contact area and Matte Tin Plating on Soldertails, 1.27?m(50?) Nickel Underplating over all
 - C= Selective 0.76?m(30?) Gold Plated on Contact area and Matte Tin Plating on Soldertails, 1.27?m(50?) Nickel Underplating over all
- ⑤ H= Right angle type
- ⑥ Mount type : S= SMT Type
- ⑦ Other options: T= With Fixed Tabs
- ⑧ NH= For Lead Free IR Process and Halogen Free

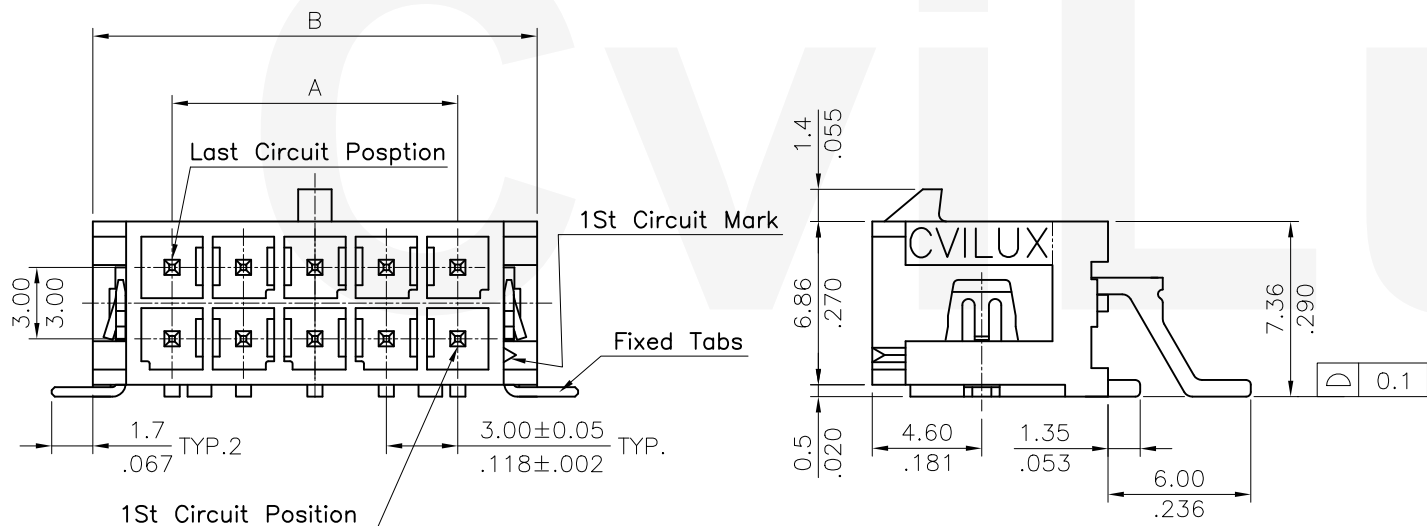

Halogen-Free

Lead Free Process

RoHS compliant

④					DATE	UNIT: mm / inch	TITLE: 3.00mm PITCH RIGHT ANGLE SMT TYPE POWER CONN.
③					DRAWN BY: Karen	8/12-14'	MATERIAL:
②					ENGINEER: Sun	8/13-14'	
①					CHECKED BY: Eisley	8/13-14'	
SYM	NAME	DATE	REVISIONS	APPROVED BY: David	8/13-14'	.XXX ± 0.10/004 .XX ±	
						TOLERANCE UNLESS OTHERWISE SPECIFIED	
						.X ± 0.30/012 .X' ± 1'	
						.XX ± 0.20/008 .X' ±	

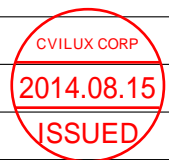

瀚荃股份有限公司
 CviLux Corporation

DRAWING NO.	CP35112SA	PART NO.	CP35**P*HST-NH
SCALE	3 / 1	SHEET	1 OF 3

CIRCUITS	DIM. A	DIM. B
2	—	6.7(.264)
4	3.00(.118)	9.7(.382)
6	6.00(.236)	12.7(.500)
8	9.00(.354)	15.7(.618)
10	12.00(.472)	18.7(.736)
12	15.00(.591)	21.7(.854)
14	18.00(.709)	24.7(.972)
16	21.00(.827)	27.7(1.091)
18	24.00(.945)	30.7(1.209)
20	27.00(1.063)	33.7(1.327)
22	30.00(1.181)	36.7(1.445)
24	33.00(1.299)	39.7(1.563)

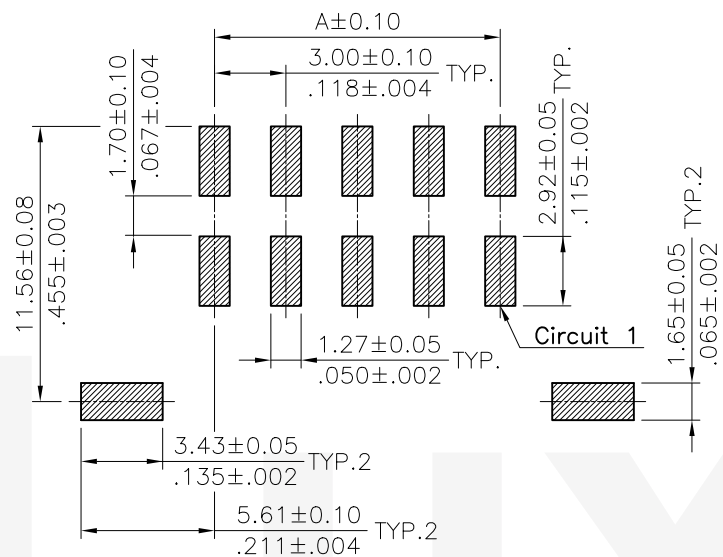

Recommended P.C. Board Layout

Halogen-Free

Lead Free Process

RoHS compliant

SYM	NAME	DATE	REVISIONS	APPROVED BY:	DATE	UNIT: mm / inch	TITLE: 3.00mm PITCH RIGHT ANGLE SMT TYPE POWER CONN.	 瀚荃股份有限公司 CviLux Corporation	DRAWING NO.	PART NO.	SHEET	OF	
4													
3				DRAWN BY:	Karen	8/12-14'	TOLERANCE UNLESS OTHERWISE SPECIFIED			CP35112SA	CP35**P*HST-NH	2	3
2				ENGINEER:	Sun	8/13-14'	.X ± 0.30/.012 X' ± 1'						
1				CHECKED BY:	Eisley	8/13-14'	.XX ± 0.20/.008 X' ±						
				APPROVED BY:	David	8/13-14'	.XXX ± 0.10/.004 XX' ±						

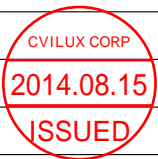

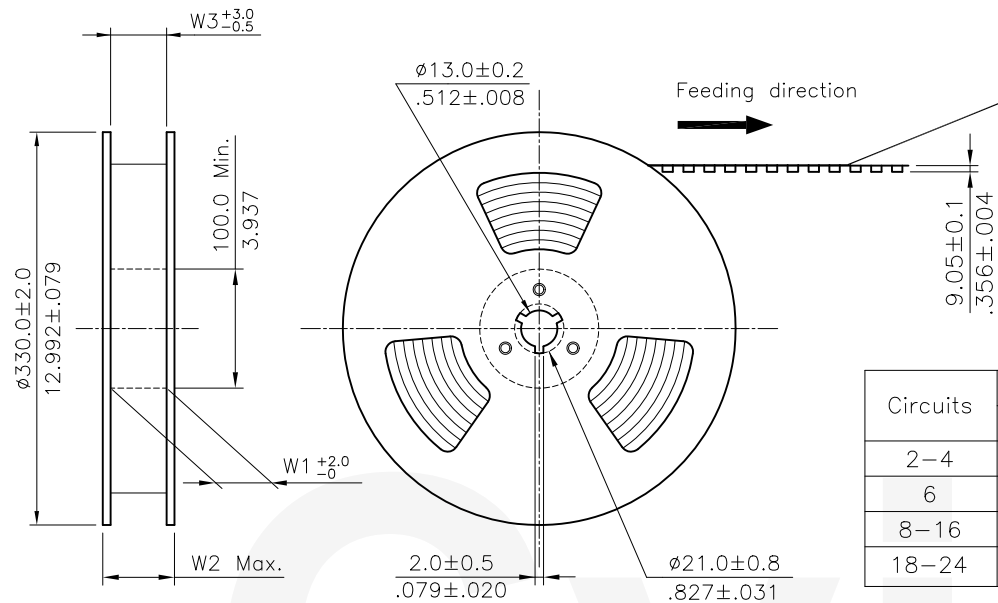

NOTE :

- * Reel Material : Corrugated Paper
- * Carrier Material : Transparent, Conductive Polystyrene Alloy
- * Cover Tape Material : Polyester
- * Cover Tape Peel Strength : 0.1N – 1.3N
- * Carrier camber is within 1mm in 250mm
- * All dimensions meet EIA-481-B requirements.
- * Quantity : 250 PCS/Reel

Circuits	Dimension					Packing (Reel/Caton)
	E	F	W1	W2	W3	
2-4	24.0(.945)	-	24.5(.965)	30.5(1.200)	24.5(.965)	9
6	32.0(1.260)	28.40(1.118)	32.5(1.280)	38.5(1.516)	32.5(1.280)	7
8-16	44.0(1.732)	40.40(1.596)	44.5(1.752)	50.5(1.988)	44.5(1.752)	5
18-24	56.0(2.205)	52.40(2.063)	56.5(2.224)	62.5(2.461)	56.5(2.224)	4

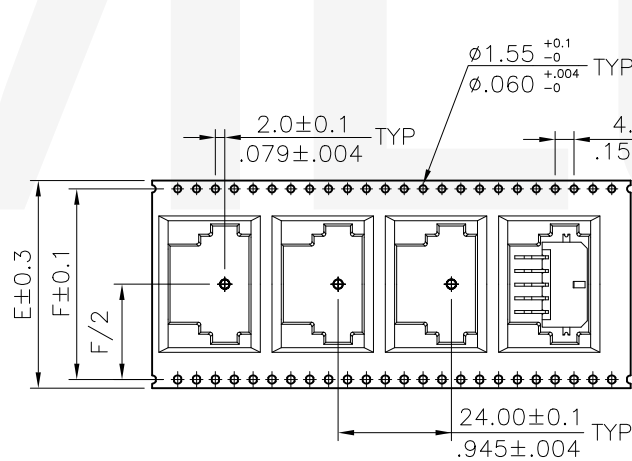
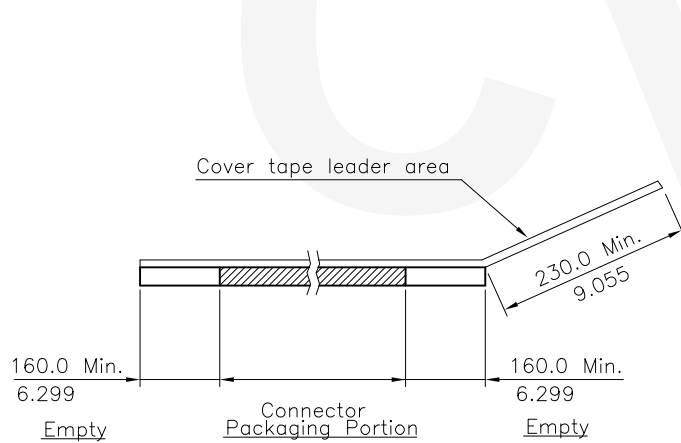

WIDTH : 32.44,56 mm Carrier

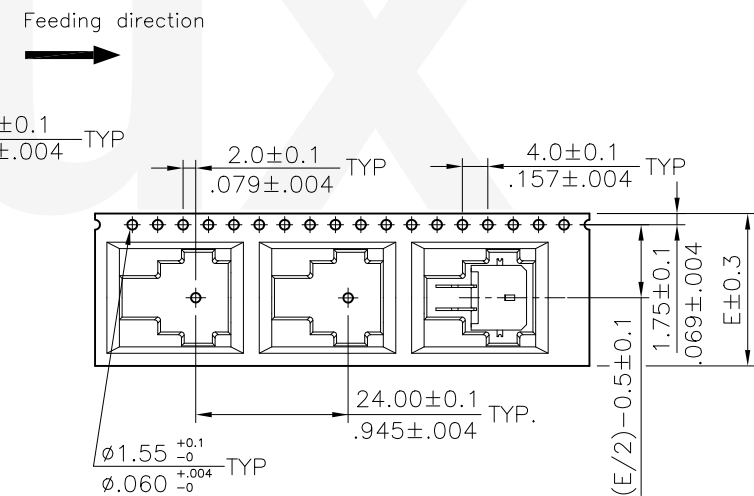

WIDTH : 24 mm Carrier

RoHS Compliant

4					DATE	UNIT: mm / inch	TITLE: 3.00mm PITCH RIGHT ANGLE SMT TYPE POWER CONN.	 瀚荃股份有限公司 CviLux Corporation
3					DRAWN BY: Karen	TOLERANCE UNLESS OTHERWISE SPECIFIED	MATERIAL:	
2					ENGINEER: Sun	.X ±	FINISH:	
1					CHECKED BY: Eisley	.XX ±		
SYM	NAME	DATE	REVISIONS	APPROVED BY: David	8/13-14'	.XXX ±	SCALE	DRAWING NO. CP35112SA PART NO. CP35**P*HST-NH
							SHEET 3 OF 3	

CVILUX CORP
 2014.08.15
 ISSUED