

SPECIFICATION FOR APPROVAL



CUSTOMER Comet Electronics

CUSTOMER'S DWG NO. _____

CUSTOMER'S PART NO _____

OUR DWG NO. MY1123368

QUANTITY _____ **DATE:** NOV 2, 2012

ITEM. DS3316-330M

	✓	CUSTOMER'S SIGNATURE	NOTE
FULL APPROVED			
CONDITIONAL APPROVED			
REJECTED			

PLEASE RETURN AFTER APPROVING







CORE MASTER ENTERPRISE CO., LTD.

**TAIWAN: 7F-1, No.129, Lane 235, Baoqiao Rd., Xindian City,
Taipei County 231, Taiwan (R.O.C.)**

TEL:886-2-89191288 FAX:886-2-89191298
<http://www.coremaster.com.tw>

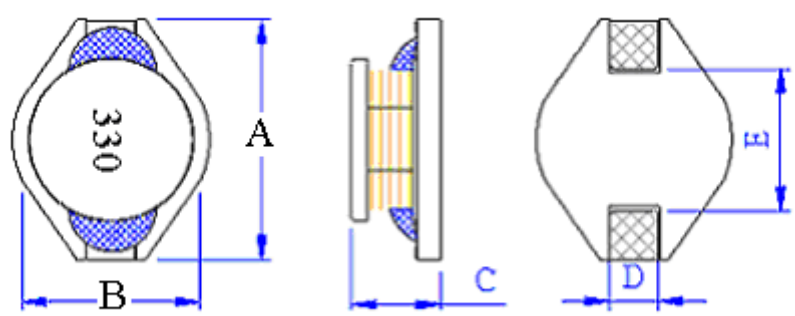
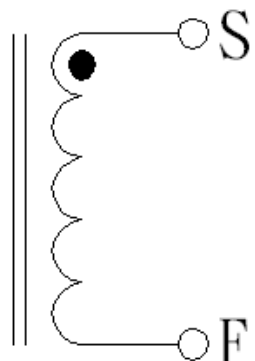
CHINA: TIANXIN, TANGXIA TOWN, DONGGUAN, GUANGDONG, CHINA
TEL:86-769-82037061 FAX:86-769-82037060



SPECIFICATION FOR APPROVAL

CUSTOMER:		DATE:
PART NO: DS3316-330M		DWG.NO: MY1123368
CUSTOMER PART NO:		CUST.DWG.NO:
<p>(1) DIMENSION(UNIT: mm)</p> 		A 13.50 (MAX) m/m
		B 9.50 (MAX) m/m
		C 5.20 (MAX) m/m
		D 2.54 (REF) m/m
		E 8.00 (REF) m/m
		F m/m
		G m/m
		H m/m
		I m/m
		J m/m
		(2)ELECTRICAL REQUIREMENTS
L (uH)	33 ± 20%	
RDC (Ω)	0.1 (MAX)	
IDC (A)	2.1 (MAX)	
TEST CONDITION	100KHZ / 0.1V	
		APPROVED BY 
		CHECKED BY 
		DRAWN BY 

CORE MASTER ENTERPRISE CO., LTD.

TEL:886-2-8919-1288 FAX:886-2-8919-1298 WEB: www.coremaster.com.tw

TEST DATA

CUSTOMER:				DATE:			
PART NO: DS3316-330M				DWG.NO: MY1123368			
CUSTOMER PART NO :				CUST.DWG.NO :			
TEST CONDITION: 100KHZ / 0.1V				DIMENSION (UNIT : mm)			
ITEM	L (uH)	RDC (Ω)	IDC (A)	A	B	C	
SPEC	33 ± 20%	0.1 (MAX)	2.1 (MAX)	13.50 (MAX)	9.50 (MAX)	5.20 (MAX)	
1	33.3	0.086	OK	12.68	9.27	4.92	
2	33.0	0.087	OK	12.70	9.28	4.94	
3	33.6	0.086	OK	12.71	9.27	4.93	
4	33.0	0.087	OK	12.69	9.25	4.87	
5	32.7	0.087	OK	12.70	9.30	4.92	
6	33.3	0.085	OK	12.68	9.27	4.91	
7	33.5	0.086	OK	12.67	9.25	4.92	
8	33.1	0.087	OK	12.67	9.27	4.90	
9	33.1	0.087	OK	12.68	9.26	4.92	
10	33.0	0.087	OK	12.64	9.30	4.95	
\bar{X}	33.16	0.087		12.682	9.272	4.918	
R	0.9	0.002		0.07	0.05	0.08	
TEST INSTRUMENTS HIOKI3532-50 LCR METER VR-131 RDC METER VR116+VR7220 BA/S CURRENT				APPROVED BY			
							
				CHECKED BY			
							
				DRAWN BY			
							

CORE MASTER ENTERPRISE CO., LTD.

TEL:886-2-8919-1288 FAX:886-2-8919-1298 WEB: www.coremaster.com.tw