

SPECIFICATION FOR APPROVAL



CUSTOMER Comet Electronics

CUSTOMER'S DWG NO. _____

CUSTOMER'S PART NO _____

OUR DWG NO. MY1305566

QUANTITY _____ **DATE:** NOV 2, 2012

ITEM. SRI1205-101M

	✓	CUSTOMER'S SIGNATURE	NOTE
FULL APPROVED			
CONDITIONAL APPROVED			
REJECTED			

PLEASE RETURN AFTER APPROVING







CORE MASTER ENTERPRISE CO., LTD.

**TAIWAN: 7F-1, No.129, Lane 235, Baoqiao Rd., Xindian City,
Taipei County 231, Taiwan (R.O.C.)**

TEL:886-2-89191288 FAX:886-2-89191298
<http://www.coremaster.com.tw>

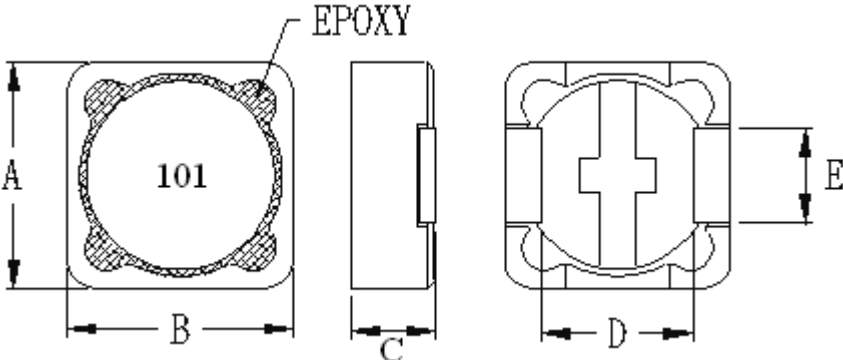
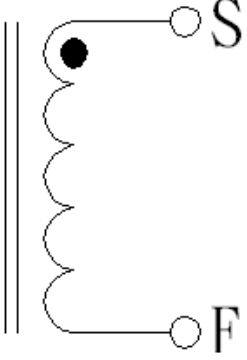
CHINA: TIANXIN, TANGXIA TOWN, DONGGUAN, GUANGDONG, CHINA
TEL:86-769-82037061 FAX:86-769-82037060



SPECIFICATION FOR APPROVAL

CUSTOMER:		DATE:
PART NO: SRI1205-101M		DWG.NO: MY1305566
CUSTOMER PART NO:		CUST.DWG.NO:
<p>(1) DIMENSION(UNIT: mm)</p> 		A 12.0 ± 0.5 m/m
		B 12.0 ± 0.5 m/m
		C 6.0 (MAX) m/m
		D 7.6 ± 0.2 m/m
		E 5.0 ± 0.2 m/m
		F m/m
		G m/m
		H m/m
		I m/m
		J m/m
		(2)ELECTRICAL REQUIREMENTS
L (uH)	100 ± 20%	
RDC (Ω)	0.17 (MAX)	
IDC (A)	1.3 (MAX)	
TEST CONDITION	1KHZ / 0.25V	
		APPROVED BY 
		CHECKED BY 
		DRAWN BY 

CORE MASTER ENTERPRISE CO., LTD.

TEL:886-2-8919-1288 FAX:886-2-8919-1298 WEB:www.coremaster.com.tw

TEST DATA

CUSTOMER:				DATE:			
PART NO: SRI1205-101M				DWG.NO: MY1305566			
CUSTOMER PART NO :				CUST.DWG.NO :			
TEST CONDITION: 1KHZ / 0.25V				DIMENSION (UNIT : mm)			
ITEM	L (uH)	RDC (Ω)	IDC (A)	A	B	C	
SPEC	100 ± 20%	0.17 (MAX)	1.3 (MAX)	12.0 ± 0.5	12.0 ± 0.5	6.0 (MAX)	
1	105.1	0.155	OK	12.06	12.01	5.63	
2	104.0	0.158	OK	12.11	12.08	5.61	
3	101.0	0.152	OK	12.13	12.07	5.67	
4	102.3	0.152	OK	12.06	12.04	5.63	
5	101.2	0.149	OK	12.03	11.97	5.61	
6	102.3	0.151	OK	11.97	12.07	5.59	
7	103.0	0.150	OK	12.06	12.03	5.65	
8	102.3	0.147	OK	12.06	12.02	5.71	
9	105.6	0.147	OK	12.07	11.98	5.62	
10	103.2	0.156	OK	12.10	11.96	5.60	
\bar{X}	103	0.152		12.065	12.023	5.632	
R	4.6	0.011		0.16	0.12	0.12	
TEST INSTRUMENTS HI0KI3532-50 LCR METER VR-131 RDC METER CH-301A BA/S CURRENT				APPROVED BY			
							
				CHECKED BY			
							
				DRAWN BY			
							

CORE MASTER ENTERPRISE CO., LTD.

TEL:886-2-8919-1288 FAX:886-2-8919-1298 WEB: www.coremaster.com.tw