

SWITCH CIRCUIT			MATERIAL AND FINISH AS BELOW						
WHEN CARD IS EJECTED		WHEN CARD IS INSERTED	A	Housing	LCP UL94V-0, Color:Ivory	E			
			B	Contact	Brass C2680, Gold Plated Over Nickel	F			
			C	Holddown	Brass C2680, Tin Plated	G			
			D			H			

**SPECIFICATION:**

**1. ELECTRICAL**

- 1.1 Current Rating: 0.5AMP
- 1.2 Voltage Rating: 100VAC
- 1.3 Contact Resistance: 40mΩ
- 1.4 Insulation Resistance: 1000MΩ
- 1.5 Dielectric Withstanding Voltage: 500VAC for 1 minute

**2. MECHANICAL**

- 2.1 Durability: 10000Cycle
- 2.2 Insertion Force: 28.8N
- 2.3 Extraction Force: 4.9N

**3. ENVIRONMENTAL**

- 3.1 Operating temperature range: -40°C to +85°
- 3.2 Storage temperature range: -40°C to +85°

**4. SOLDER ABILITY**

- 4.1 Recommended IR Reflow Temperature: 260°C 10Sec

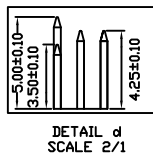
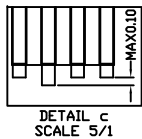
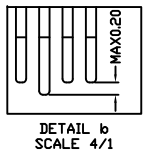
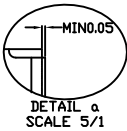
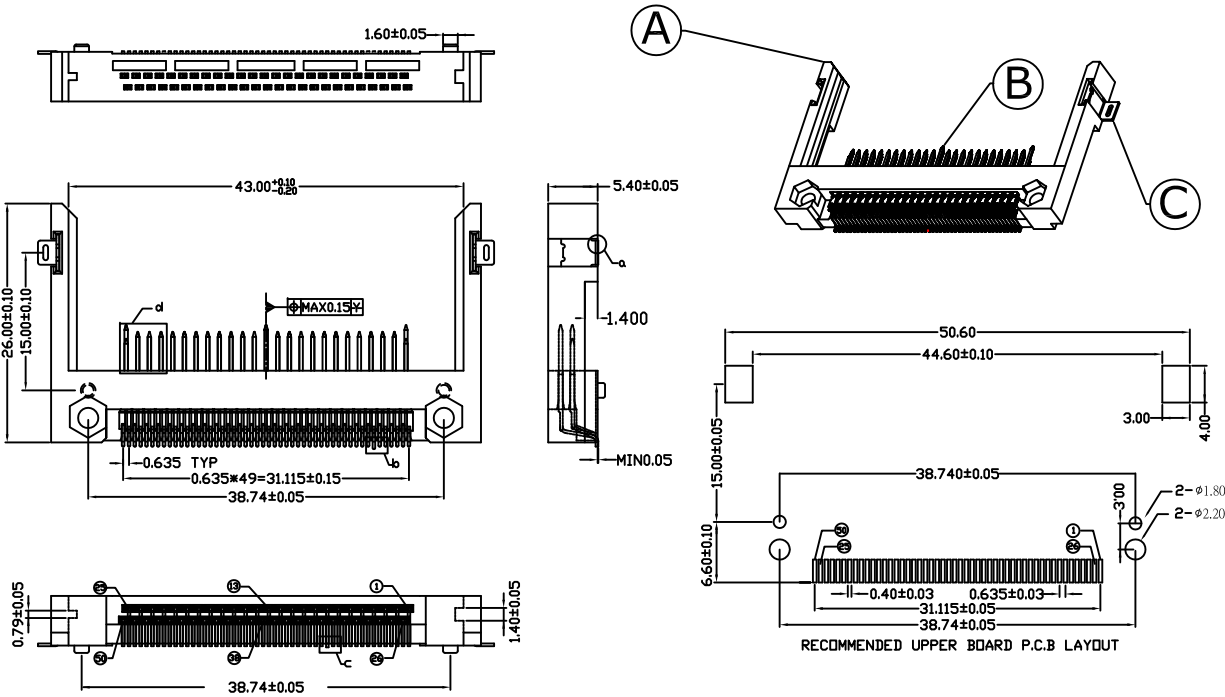

PIN NUMBER	DIML
25 26	3.50
ALL OTHER PINS	4.25
1 13 38 50	5.00

P1	P2	P3	P4	P5	P6	P7	P8	P9	P10	P11	P12
----	----	----	----	----	----	----	----	----	-----	-----	-----

**PIN ASSIGNMENT**

101D-TACB-R01 CF Socket Slim Type Peg:38.74, S/O:1.4mm, Contact Area:Gold Flash

PRODUCT NO. DESCRIPTION

UNLESS OTHERWISE SPECIFIED TOLERANCE		
ANGLES	ANG.	±5°
LINEAR	0.	±0.3
	0.0	±0.25
	0.00	±0.20
SCALE	AS SHOWN	UNIT: mm
DRAWN	Willis	2012/12/27
CHECKED	Angel	2012/12/27
APPROVED	Ken	2012/12/27



www.attend.com.tw

DRAWN NAME: CF Slim Type Socket  
Locating Peg:38.74,Stand off 1.4mm

PRODUCT NO. 101D-TACB-R01

REV.	DESCRIPTION	DATE	REV.	DESCRIPTION	DATE
1			4		
2			5		
3			6		
Revise:					
Revise:					
Revise:					