

Material:

* Insulation:

Base & Cover: Glass Filled Polyester UL 94V-0

* Contact: Phosphor Bronze

* Accommodated Cables:

1.27mm(.050")Center spacing Flat

Cable Insulator O.D.: 0.85 mm dia.

* Construction: AWG #28 (7/0.127mm)

Ordering Code:

CA30 ** P 1 3 I *

① ② ③ ④ ⑤ ⑥ ⑦

① Series No.:

② No. of Circuits: 04 to 26

③ Contacts Type: P= Pin Header

④ Plating option:

1= Tin over Nickel plated
(Matte Tin plated)

⑤ Color: 3= Red

⑥ Type: I = IDC Type

⑦ Option: 0= Standard (Tube Packing)

R= Tape & Reel Packing

DIM.A= 1.27 x No. of Spaces

DIM.B= DIM.A + 3.3

DIM.C= DIM.A + 2.1

DIM.D= DIM.A + 4.7

*Available in 4 ~ 26 Circuits

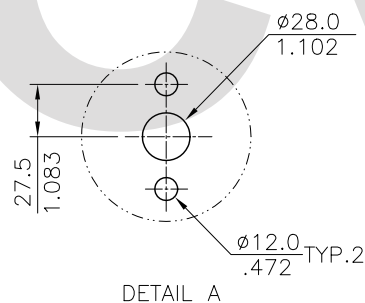
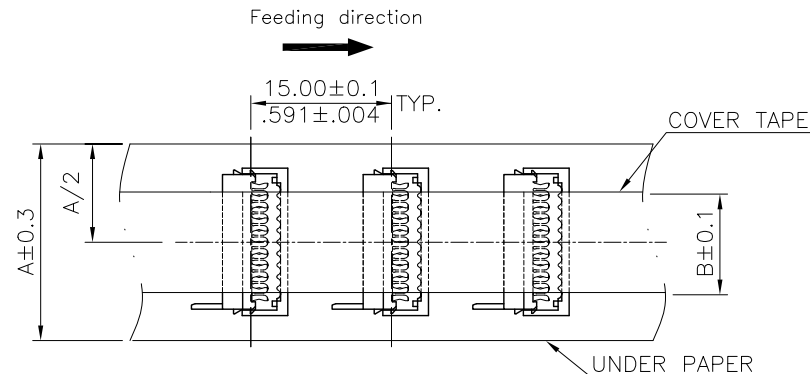
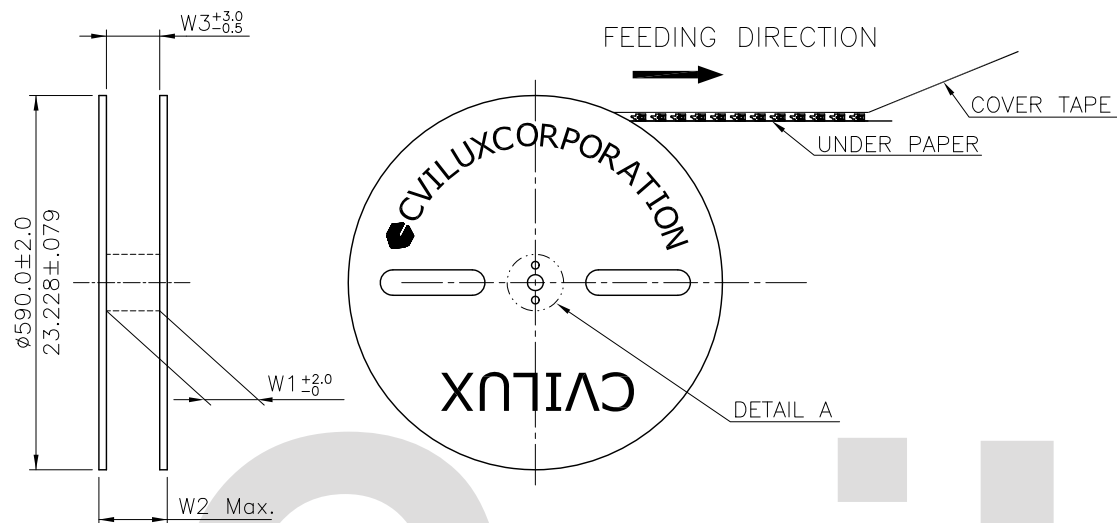

RoHS Compliant

④						DATE	UNIT: mm / inch	TITLE: 1.27mm Pitch Male IDC Type Connector	 瀚荃股份有限公司 CviLux Corporation
③	Una	11/11-10'	ECN10365	2010.12.07	DRAWN BY: Una	11/11-10'	TOLERANCE UNLESS OTHERWISE SPECIFIED	MATERIAL:	
②	Sun	11/19-09'	ECN09528	ISSUED	ENGINEER: Clark	11/17-10'	.X ± 0.30/.012 X' ± 1"	DRAWING NO. CA3001SD PART NO. CA30**P13I*	
①	Hank	3/12-09'	ECN09122		CHECKED BY: David	11/17-10'	.XX ± 0.20/.008 .X' ±		
SYM	NAME	DATE	REVISIONS		APPROVED BY: David	11/17-10'	.XXX ± 0.10/.004 .XX ±	FINISH:	DRAWING NO. CA3001SD PART NO. CA30**P13I* SCALE 4 / 1 SHEET 1 OF 2



Circuits	Dimension				
	A	B	W1	W2	W3
4	11.0(.433)	6.0(.236)	13.0(.512)	23.0(.906)	13.0(.512)
6	17.0(.669)	6.0(.236)	18.0(.709)	28.0(1.102)	18.0(.709)
8	17.0(.669)	6.0(.236)	18.0(.709)	28.0(1.102)	18.0(.709)
10	21.0(.827)	6.0(.236)	22.0(.866)	32.0(1.260)	22.0(.866)
12	21.0(.827)	6.0(.236)	22.0(.866)	32.0(1.260)	22.0(.866)
14	24.0(.945)	6.0(.236)	25.0(.984)	35.0(1.378)	25.0(.984)
16	29.0(1.142)	6.0(.236)	30.0(1.181)	40.0(1.575)	30.0(1.181)
18	29.0(1.142)	6.0(.236)	30.0(1.181)	40.0(1.575)	30.0(1.181)
20	32.0(1.260)	6.0(.236)	33.0(1.299)	43.0(1.693)	33.0(1.299)
22	36.0(1.417)	6.0(.236)	37.0(1.457)	47.0(1.850)	37.0(1.457)
24	36.0(1.417)	6.0(.236)	37.0(1.457)	47.0(1.850)	37.0(1.457)
26	39.0(1.535)	6.0(.236)	40.0(1.575)	50.0(1.969)	40.0(1.575)

* Quantity : 2500 PCS/Reel/Caton

4						DATE	UNIT: mm / inch	TITLE: TAPE & REEL PACKAGING FOR CA30 SERIES SMT TYPE	 瀚荃股份有限公司 CviLux Corporation	
3	Una	11/11-10'	ECN10365		DRAWN BY:	Una	11/11-10'	MATERIAL:		
2	Sun	11/19-09'	ECN09528		ENGINEER:	Clark	11/17-10'		FINISH:	
1	Hank	3/12-09'	ECN09122		CHECKED BY:	David	11/17-10'	DRAWING NO. CA3001SD		PART NO. CA30**P13I*
SYM	NAME	DATE	REVISIONS		APPROVED BY:	David	11/17-10'	.X ±	.X* ± 1'	SCALE
							.XX ±	.X* ±		
							.XXX ±	.XX* ±		