

**NEW**

## AN SERIES

DIMENSIONS ( Unless otherwise specified, a tolerance of ±0.4mm applies to all dimensions. )

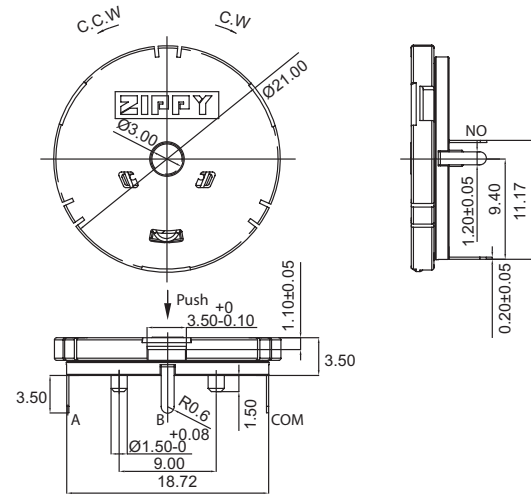

### SPECIFICATIONS

Operation force .....Rotation Max.50 gf-cm push 220±40gf  
 Contact Resistance ( initial ) ..... Max. 300mΩ  
 Insulation Resistance ( at 100VDC/minute ) .....Min. 100MΩ  
 Storage Temperature range ..... -40° to 70°  
 Storage Humidity .....at 40°, Max. 85% R.H  
 Electrical Service Life ..... Rotation - Min. 200,000 operations  
 (C.W. 100,000 & C.C.W 100,000operations)  
 Push - Min. 1,000,000 operations  
 Electrical Operating Frequency ...Rotation - 30 operations per minute  
 Push -120 operations per minute

### CONTACT CONFIGURATION

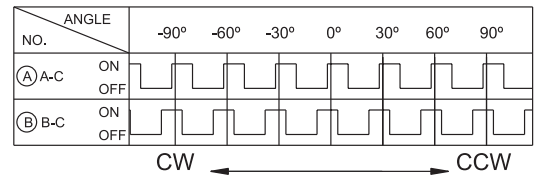
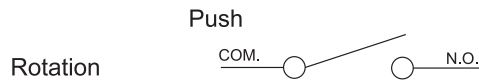

Numbers of detent : 24  
 Pulse/Rotation : 12 pulse/360°

### RATING

1mA 10 VDC

### MOUNTING HOLES

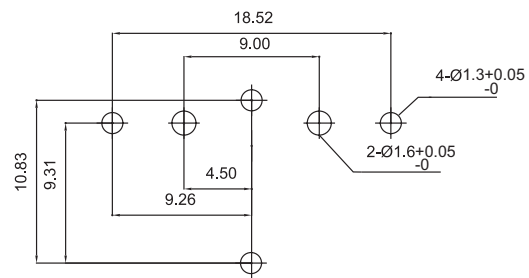

### ORDERING INFORMATION

