

JOY-IT

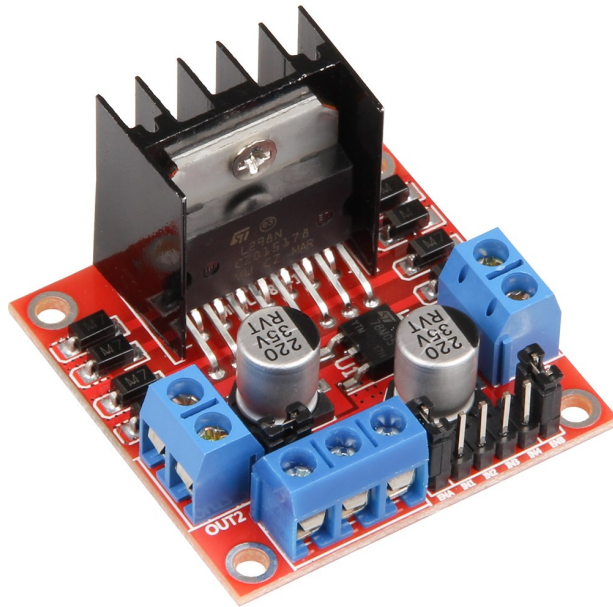

MotoDriver2

TABLE OF CONTENTS

1. Introduction
2. Device Overview
3. Using with an Arduino
 - 3.1 Connection
 - 3.2 Example-Code
4. Using with a Raspberry Pi
 - 4.1 Connection
 - 4.2 Example-Code
5. Additional Informations
6. Support

1. INTRODUCTION

Dear customer,
thank you very much for choosing our product. In the following we have listed what you have to consider during the setup.

2. DEVICE OVERVIEW

The MotoDriver2 is an expansion board that allows the control and use of up to two DC motors. The DC motors can be controlled with a constant voltage between 5V and 35V.

Model	SBC-MotoDriver2
Driver	L298N
Logic Voltage	5V
Drive Voltage	5V - 35V
Drive Current	2A
Power	Max. 25W
Dimensions	43 x 43 x 25 mm

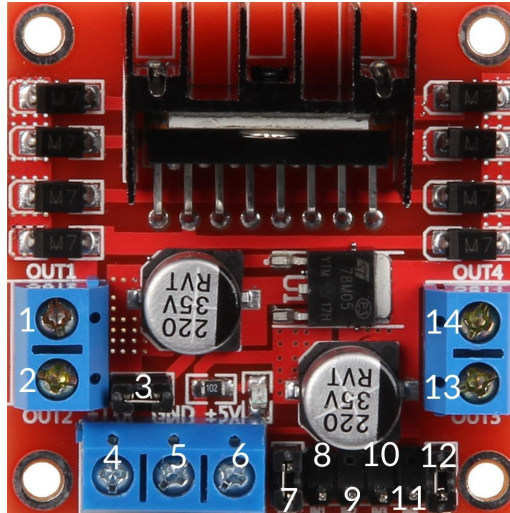

PIN	Assignment
1	DC Motor 1 / Stepper Motor +
2	DC Motor 1 / Stepper Motor GND
3	12V Jumper
4	Power Supply +
5	Power Supply GND
6	5V Output (if Jumper 3 is set)
7	DC Motor 1 Jumper
8	Input 1
9	Input 2
10	Input 3
11	Input 4
12	DC Motor 2 Jumper
13	DC Motor 2 / Stepper Motor +
14	DC Motor 2 / Stepper Motor GND

Notice:

Remove the jumper from slot 3 if the power supply is above 12V. This will activate power to the Onboard 5V Regulator. The 5V output is ideal for powering an Arduino, for example. This is only active if the jumper is set to slot 3.

3. USING WITH AN ARDUINO

3.1 CONNECTION

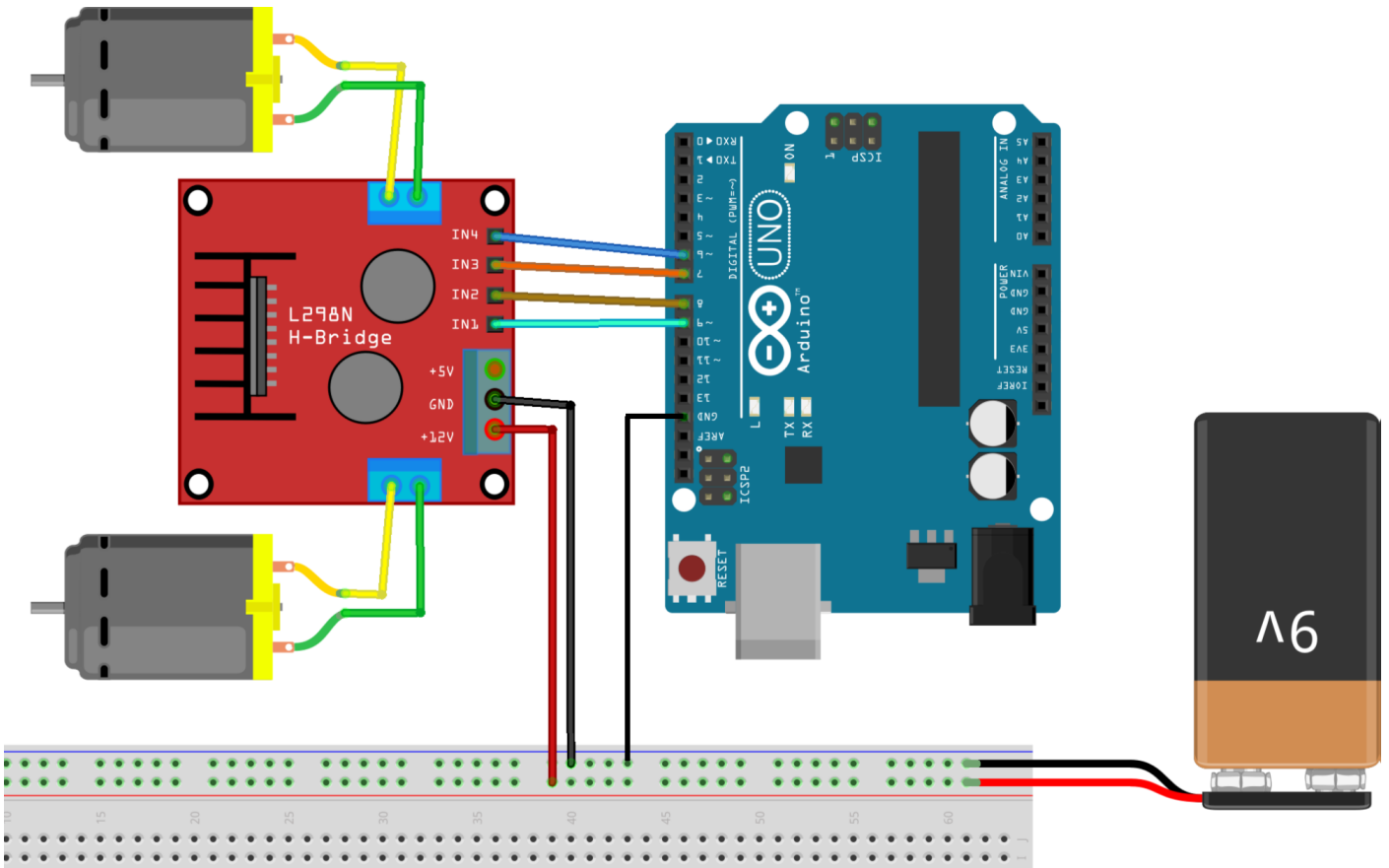

MotoDriver 2	Arduino
Input 1	9
Input 2	8
Input 3	7
Input 4	6

The power supply for the MotoDriver2 (PIN 4) should be between 5V and 35V. This depends on your configuration and the used components.

3.2 EXAMPLE-CODE

To use the DC motors on the module, connect the motors, the module and your Arduino as shown in the previous picture. Transfer the following code example completely to your Arduino to test the functionality.

```
//Motor 1
const int motorPin1 = 9;
const int motorPin2 = 8;
//Motor 2
const int motorPin3 = 7;
const int motorPin4 = 6;
int speed = 180;

void setup(){
  //Set pins as outputs
  pinMode(motorPin1, OUTPUT);
  pinMode(motorPin2, OUTPUT);
  pinMode(motorPin3, OUTPUT);
  pinMode(motorPin4, OUTPUT);
  //Motor Control A in both directions
  analogWrite(motorPin1, speed);
  delay(2000);
  analogWrite(motorPin1, 0);
  delay(200);
  analogWrite(motorPin2, speed);
  delay(2000);
  analogWrite(motorPin2, 0);
  //Motor Control B in both directions
  analogWrite(motorPin3, speed);
  delay(2000);
  analogWrite(motorPin3, 0);
  delay(200);
  analogWrite(motorPin4, speed);
  delay(2000);
  analogWrite(motorPin4, 0);
}

void loop(){
}
```

4. USING WITH A RASPBERRY PI

4.1 CONNECTION

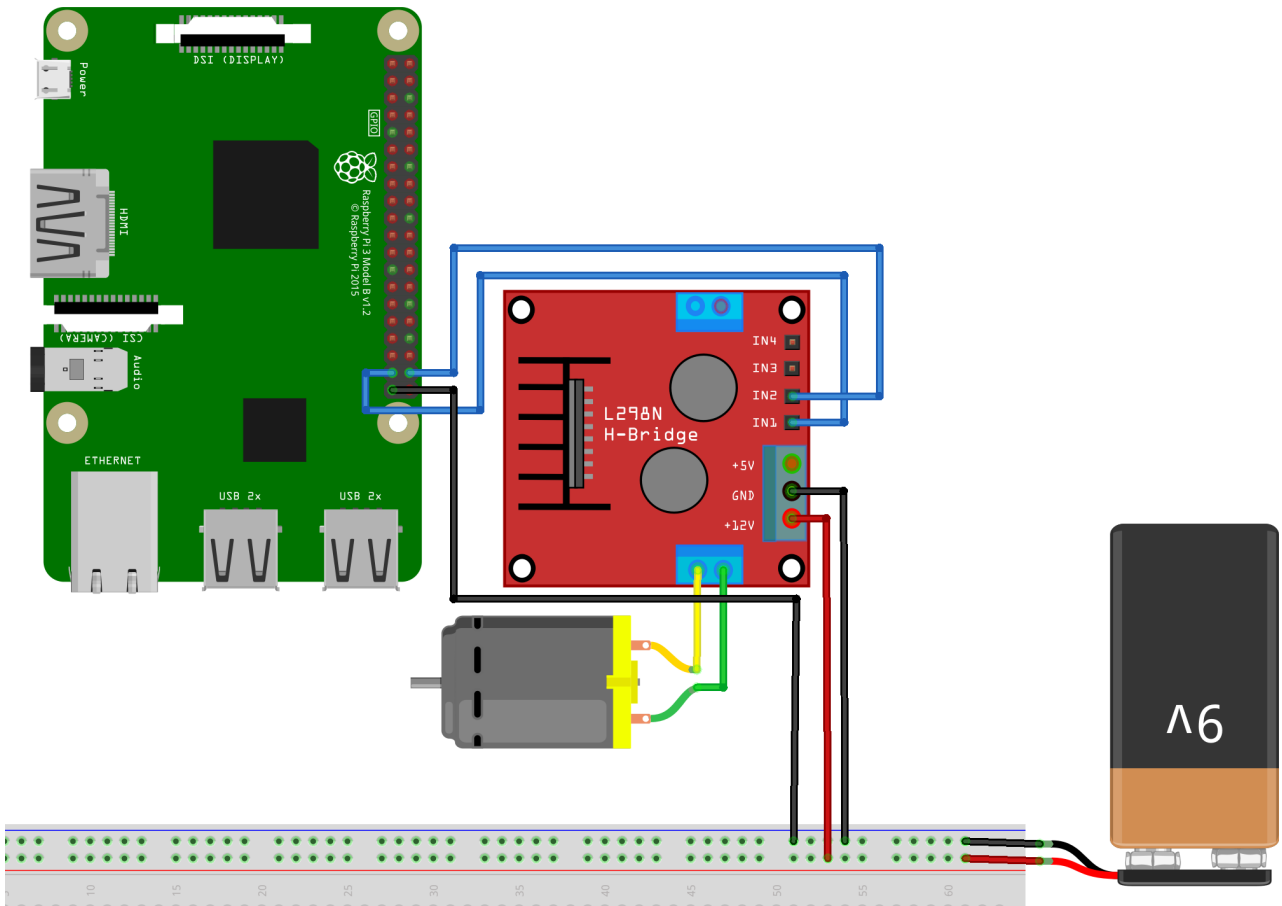

MotoDriver 2	Arduino
Input 1	GPIO26
Input 2	GPIO20

The power supply for the MotoDriver2 (PIN 4) should be between 5V and 35V. This depends on your configuration and the used components.

4.2 EXAMPLE-CODE

To use DC motors on the module, simply connect the motors, the module and your Raspberry Pi, as shown in the previous picture. Transfer the following code example completely to your Raspberry Pi to test the functionality.

```
import sys
import time
import RPi.GPIO as GPIO

mode=GPIO.getmode()

GPIO.cleanup()

Forward=26
Backward=20

GPIO.setmode(GPIO.BCM)
GPIO.setup(Forward, GPIO.OUT)
GPIO.setup(Backward, GPIO.OUT)

def forward(x):
    GPIO.output(Forward, GPIO.HIGH)
    print("Moving Forward")
    time.sleep(x)
    GPIO.output(Forward, GPIO.LOW)

def reverse(x):
    GPIO.output(Backward, GPIO.HIGH)
    print("Moving Backward")
    time.sleep(x)
    GPIO.output(Backward, GPIO.LOW)

while (1):

    forward(5)
    reverse(5)
    GPIO.cleanup()
```

5. ADDITIONAL INFORMATIONS

Our information and take-back obligations according to the Electrical and Electronic Equipment Act (ElektroG)

Symbol on electrical and electronic equipment:



This crossed-out dustbin means that electrical and electronic equipment does not belong in the household waste. You must return the waste to a collection point.

Before handing over waste batteries and accumulators that are not enclosed by waste equipment must be separated from it.

Return options:

As an end user, you can return your old device (which essentially fulfils the same function as the new device purchased from us) free of charge for disposal when you purchase a new device.

Small appliances with no external dimensions greater than 25 cm can be disposed of in normal household quantities independently of the purchase of a new appliance.

Possibility of return at our company location during opening hours:

Simac GmbH, Pascalstr. 8, D-47506 Neukirchen-Vluyn, Germany

Possibility of return in your area:

We will send you a parcel stamp with which you can return the device to us free of charge. Please contact us by e-mail at Service@joy-it.net or by telephone.

Information on packaging:

If you do not have suitable packaging material or do not wish to use your own, please contact us and we will send you suitable packaging.

6. SUPPORT

We are also there for you after the purchase. If you still have questions or problems, we are also available by e-mail, telephone and ticket support system.

E-Mail: service@joy-it.net

Ticket-System: <http://support.joy-it.net>

Phone: +49 (0)2845 98469 – 66 (9:30 - 17:00 o'clock)

For further information please visit our website:

www.joy-it.net