

# SPECIFICATION SHEET

## 規格圖面

**LEAD FREE**

提出年月日 Date of application  

2006	04	01
(year)	(month)	(date)

**CUSTOMER (客戶)**

**COMET**

品名

Description:

**VOLTAGE STEP UP COIL**

顧客品番

CUST. Part Number:

CEC品番

CEC Part Number:

**CYAG-873465NP**

規格圖面提出區分 CLASSIFICATION OF SPEC. PRESENTATION. ( Tick the relevant box " ✓ ")

- 新規 New application
- 新規部品追記 New part(s) is added to accepted specification
- 即存規格圖變更 Revision of accepted specification



備考 Note

蓋上確認後,請返卻一份給我公司. Please send us the specification with acceptance stamp.

客戶受領印 (ACCEPTANCE STAMP)



**高雅線圈制品有限公司**  
**COILS ELECTRONIC CO., LTD.**

承認 APPROVAL	審查 CHECK	作成 PREPARE
		

# \*SPECIFICATION\*

**LEAD FREE**

CUSTOMER : COMET <hr/> CUS. PART NO. : <hr/> COILS PART NO. : CYAG-873465NP <hr/> DATE : 2006/04/01 <hr/>	APPROVED BY <hr/>
---	----------------------

### 1. MATERIAL , WINDING

CORE	EL8H (or equivalent)	TUBE	UL
URNS	(1-2) 220 <sup>2</sup> / <sub>3</sub> T (2-3) 1550 <sup>2</sup> / <sub>3</sub> T (Ref.)	WIRE	Ø0.10 mm (2UEW)

### 2. DIMENSIONS (UNIT : mm)

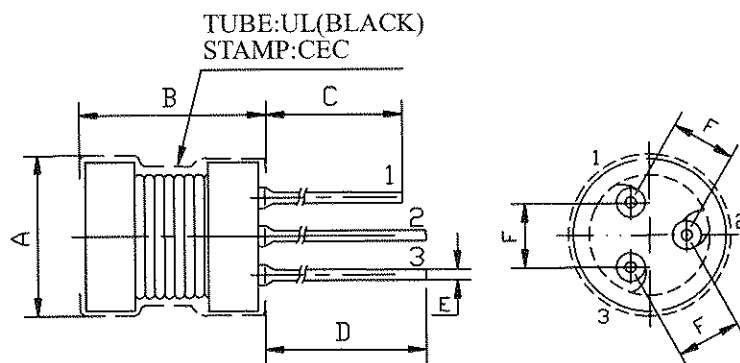

A	Ø11.0 Max.
B	18.0 Max.
C	15.0±2.0
D	20.0±2.0
E	Ø0.8±0.1
F	5.0±0.5

### 3. CIRCUIT

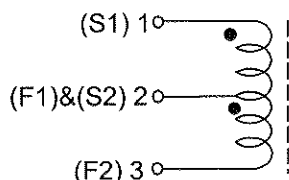

### 4. CHARACTERISTICS



ITEM	SPEC.	TESTING CONDITION	MEASUREMENT INSTRUMENT
INDUCTANCE	(1-2) 2.0mH±10%	1kHz/1V	HP-4284A
	(2-3) 90mH±10%		
Rdc	(1-2) 10Ω Max.	at 25°C	HP-34420A
	(2-3) 92Ω Max.		

### 5. REMARKS:

\* THE LEAD 1 IS SHORTER.

### 6. RoHS COMPLIANCE REMARKS

\* LEAD WILL BE PRESENT IN THE FERRITE CORE OF THE FRIT MATRIX IN THE COMPONENT. THIS USE, IS EXEMPT FROM RoHS LEGISLATION PER THE ANNEX (ITEM 7), WHICH REFERS TO "LEAD IN ELECTRONIC CERAMIC PART"

APPROVAL	CHECK	DESIGN	REVISION
			

# \*SPECIFICATION\*

LEAD FREE

CUSTOMER : COMET  
 CUS. PART NO. :  
 COILS PART NO. : CYAG-873465NP  
 DATE : 2006/04/01

APPROVED BY

## 7. CONSTRUCTION

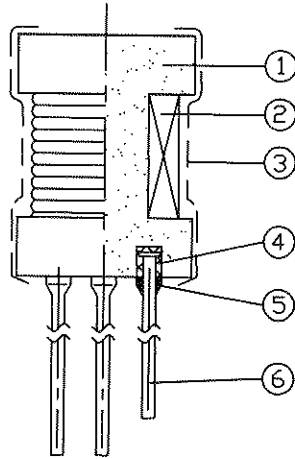

## 8. MATERIAL LIST

No.	PARTS	MATERIAL	MANUFACTURER	COUNTRY OF ORIGIN	UL No.	UL FLAME CLASS	TEMP. CLASS
①	CORE	FERRITE CORE EL8H OR EQUIVALENT	ZHONGSHAN TONICHI FERRITE PRODUCTS CO., LTD.	CHINA	NA	NA	NA
②	WIRE	POLYURETHANE ENAMELLED COPPER WIRE OR EQUIVALENT	PACIFIC-THAI ELECTRIC WIRE & CABLE CO., LTD.	THAILAND	E142108	NA	130°C
			JUNG SHING WIRE CO., LTD.	CHINA (TAIWAN)	E174837	NA	130°C
③	TUBE	HEAT SHRINKABLE UL TUBING OR EQUIVALENT	DONGGUAN SANLIAN PLASTIC CO., LTD.	CHINA	E209436	NA	125°C
④	ADHESIVE	EPOXY RESIN (EB360) OR EQUIVALENT	JIANG SU CHANG FENG CO., LTD.	CHINA	NA	NA	NA
⑤	SOLDER	Sn99.3-Cu0.7 OR EQUIVALENT	ALPHA METALS LTD.	CHINA HONG KONG	NA	NA	NA
⑥	LEAD PIN	SOLDER PLATED COPPER WIRE OR EQUIVALENT	WELL FORE SPECIAL WIRE CORPORATION	CHINA	NA	NA	NA
	STAMP	INK (PVA103) OR EQUIVALENT	SUNBEAMS CHEMICALS LIMITED	CHINA	NA	NA	NA

\* NA: NOT APPLICABLE.

APPROVAL	CHECK	DESIGN	REVISION