

TGS 2611-C00 - for the detection of Methane

Features:

- * Quick response
- * Low power consumption
- * Long life and low cost
- * Uses simple electrical circuit

Applications:

- * Portable gas detectors
- * Gas leak detector for gas appliances

TGS2611-C00 is a semiconductor type gas sensor which combines very high sensitivity to methane gas with low power consumption and long life. Due to miniaturization of its sensing chip, TGS2611-C00 requires a heater current of only 56mA and the device is housed in a standard TO-5 package.

TGS2611-C00 possesses small size and quick gas response, making it suitable for gas leakage checkers.

The TGS2611-C00 is able to satisfy the requirements of performance standards such as UL1484 and EN50194.

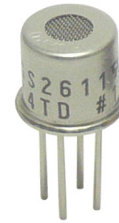

The figure below represents typical sensitivity characteristics, all data having been gathered at standard test conditions (see reverse side of this sheet). The Y-axis is indicated as sensor resistance ratio (R_s/R_o) which is defined as follows:

- R_s = Sensor resistance at various concentrations
- R_o = Sensor resistance in 5000ppm of methane

The figure below represents the typical response pattern when the sensor is inserted into and later removed from 5000ppm of methane.

Sensitivity Characteristics:

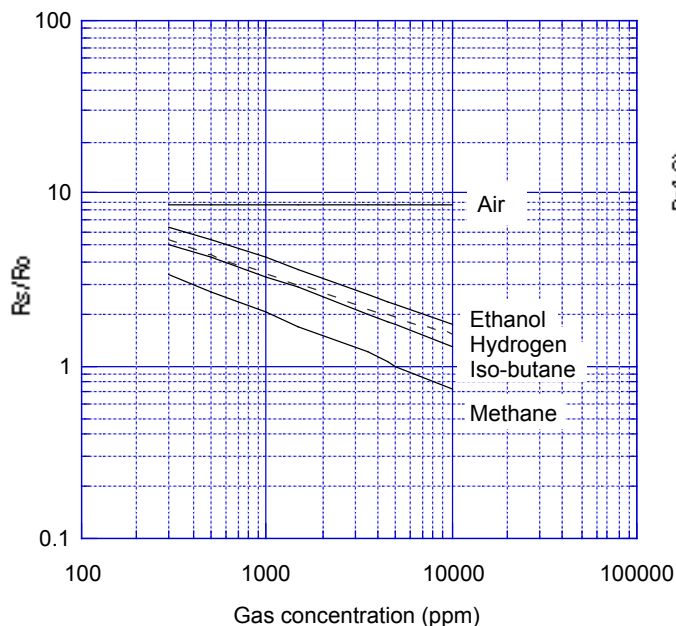

Gas Response to Methane:

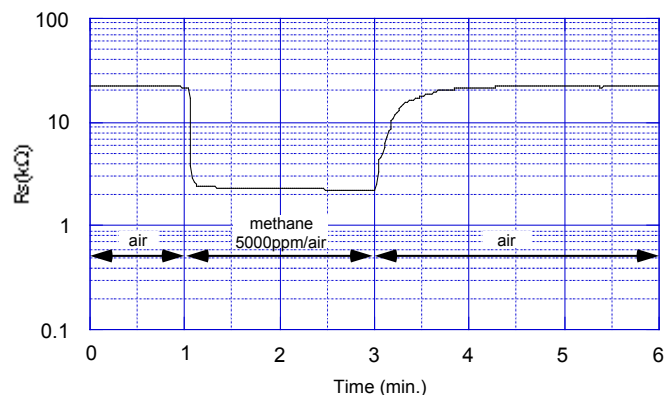

IMPORTANT NOTE: OPERATING CONDITIONS IN WHICH FIGARO SENSORS ARE USED WILL VARY WITH EACH CUSTOMER'S SPECIFIC APPLICATIONS. FIGARO STRONGLY RECOMMENDS CONSULTING OUR TECHNICAL STAFF BEFORE DEPLOYING FIGARO SENSORS IN YOUR APPLICATION AND, IN PARTICULAR, WHEN CUSTOMER'S TARGET GASES ARE NOT LISTED HEREIN. FIGARO CANNOT ASSUME ANY RESPONSIBILITY FOR ANY USE OF ITS SENSORS IN A PRODUCT OR APPLICATION FOR WHICH SENSOR HAS NOT BEEN SPECIFICALLY TESTED BY FIGARO.

Basic Measuring Circuit:

The sensor requires two voltage inputs: heater voltage (V_H) and circuit voltage (V_C). The heater voltage (V_H) is applied to the integrated heater in order to maintain the sensing element at a specific temperature which is optimal for sensing. Circuit voltage (V_C) is applied to allow measurement of voltage $V_{OUT}(V_{RL})$ across a load resistor (R_L) which is connected in series with the sensor.

A common power supply circuit can be used for both V_C and V_H to fulfill the sensor's electrical requirements. The value of the load resistor (R_L) should be chosen to optimize the alarm threshold value, keeping power dissipation (P_S) of the semiconductor below a limit of 15mW. Power dissipation (P_S) will be highest when the value of R_S is equal to R_L on exposure to gas.

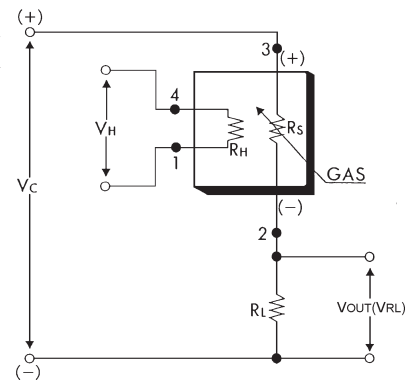

Specifications:

Model number		TGS2611-C00	
Sensing principle		MOS type	
Standard package		TO-5 metal can	
Target gases		Methane, Natural Gas	
Typical detection range		1~25% LEL	
Standard circuit conditions	Heater voltage	V_H	5.0±0.2V AC/DC
	Circuit voltage	V_C	5.0±0.2V DC $P_S \leq 15mW$
	Load resistance	R_L	variable 0.45kΩ min.
Electrical characteristics under standard test conditions	Heater resistance	R_H	approx 59Ω at room temp.
	Heater current	I_H	56±5mA
	Heater power consumption	P_H	280mW±25mW
	Sensor resistance	R_S	0.68~6.8kΩ in 5000ppm methane
	Sensitivity (change ratio of R_S)		0.54~0.66 in methane R_S (9000ppm) / R_S (3000ppm)
Standard test conditions	Test gas conditions	Methane in air at 20±2°C, 65±5%RH	
	Circuit conditions	$V_C = 5.0 \pm 0.01V$ DC $V_H = 5.0 \pm 0.05V$ DC	
	Conditioning period before test	7 days	

Structure and Dimensions:

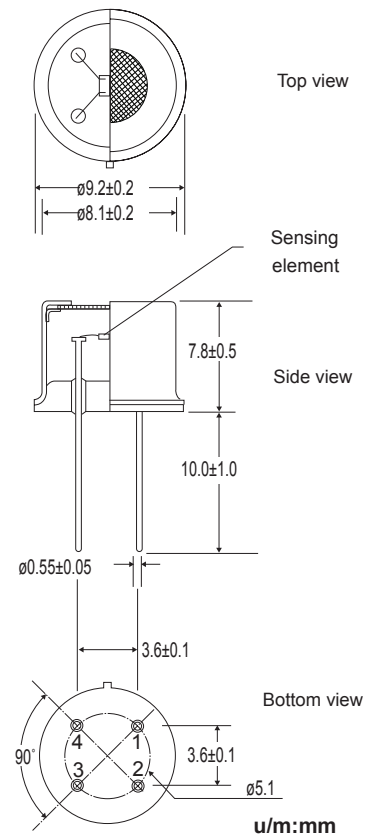

Pin connection:

- 1: Heater
- 2: Sensor electrode (-)
- 3: Sensor electrode (+)
- 4: Heater

The value of power dissipation (P_S) can be calculated by utilizing the following formula:

$$P_S = \frac{(V_C - V_{RL})^2}{R_S}$$

Sensor resistance (R_S) is calculated with a measured value of V_{OUT} (V_{RL}) by using the following formula:

$$R_S = \left(\frac{V_C}{V_{RL}} - 1 \right) \times R_L$$

All sensor characteristics shown in this brochure represent typical characteristics. Actual characteristics vary from sensor to sensor. The only characteristics warranted are those in the Specification table above.

FIGARO ENGINEERING INC.
1-5-11 Senba-nishi
Mino, Osaka 562-8505 JAPAN
Phone: (81)-72-728-2561
Fax: (81)-72-728-0467
email: figaro@figaro.co.jp
www.figaro.co.jp