

TGS 6812-D00 - for the detection of Hydrogen, Methane, and LP Gas

Features:

- * Linear output
- * Long life
- * Small sensitivity to organic vapors
- * Sensitive to hydrogen, methane, and LP gas

The **TGS6812-D00** catalytic type gas sensor can detect levels of hydrogen up to 100%LEL. This sensor features high accuracy, good durability and stability, quick response, and linear output. This sensor can detect not only hydrogen, but also methane and LP gas, thus making it an excellent solution for monitoring gas leakage from stationary fuel cell systems which transform combustible gases into hydrogen.

As the sensor possesses an adsorbent inside its sensor cap, its cross sensitivity to organic vapors is small. In addition, TGS6812-D00 is durable against silicone compounds in harsh environments.

Applications:

- * Hydrogen and combustible gas leak detectors for fuel cells



The figure below represents typical sensitivity characteristics, all data having been gathered at standard test conditions (see reverse side of this sheet). The Y-axis is indicated as sensor output sensitivity -- ΔV_{out} (mV):

$$\Delta V_{out} = V_{out \text{ in gas}} - V_{out \text{ in air}}$$

The figure below represents typical temperature dependency characteristics at 65%RH. Again, Y-axis is indicated as sensor output sensitivity -- ΔV_{out} (mV):

$$\Delta V_{out} = V_{out \text{ in gas}} - V_{out \text{ in air at } 20^\circ\text{C}}$$

Sensitivity Characteristics:

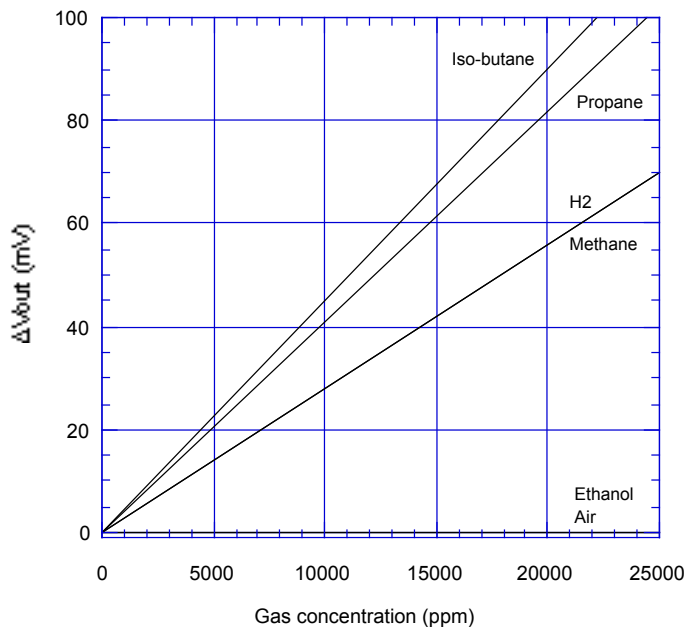

Temperature Dependency:

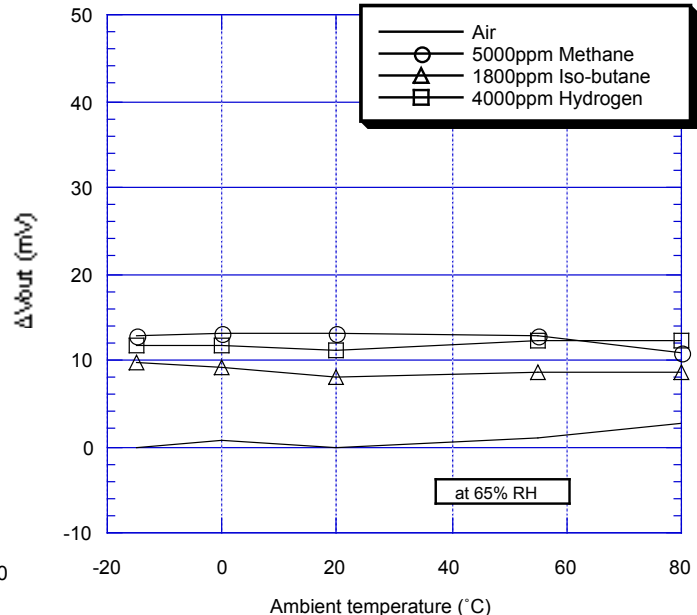

IMPORTANT NOTE: OPERATING CONDITIONS IN WHICH FIGARO SENSORS ARE USED WILL VARY WITH EACH CUSTOMER'S SPECIFIC APPLICATIONS. FIGARO STRONGLY RECOMMENDS CONSULTING OUR TECHNICAL STAFF BEFORE DEPLOYING FIGARO SENSORS IN YOUR APPLICATION AND, IN PARTICULAR, WHEN CUSTOMER'S TARGET GASES ARE NOT LISTED HEREIN. FIGARO CANNOT ASSUME ANY RESPONSIBILITY FOR ANY USE OF ITS SENSORS IN A PRODUCT OR APPLICATION FOR WHICH SENSOR HAS NOT BEEN SPECIFICALLY TESTED BY FIGARO.

Basic Measuring Circuit:

The TGS6812 is comprised of two elements: 1) element (D) which is sensitive to combustible gases and 2) a reference element (C) which is not sensitive to combustible gases. These elements are installed into a "Wheatstone Bridge". A variable resistor should be adjusted so that the bridge will produce a stable baseline signal when in an environment free of combustible

gases. When combustible gases are present, they will be combusted on the detecting element, causing its temperature to rise. Accordingly the resistance of this element will increase. This results in an "out-of-balance" signal across the bridge and a corresponding change in output voltage which can be measured.

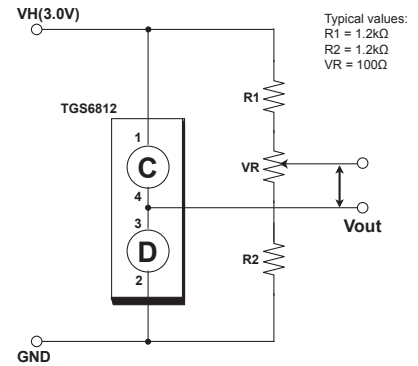

Specifications

Model number		TGS 6812-D00		
Sensing element type		Catalytic		
Target gases		Hydrogen, methane, iso-butane		
Typical detection range		0~100%LEL of each gas		
Standard circuit conditions	Operating voltage	3.0±0.1V AC/DC		
	Heater current	175mA (typical)		
Electrical characteristics under standard test conditions	Heater power consumption	525mW (typical)		
	Zero offset	-15 ~ +55mV		
	Output sensitivity (ΔVout)	hydrogen	8~16mV in 4000ppm	
		methane	10~18mV in 5000ppm	
		iso-butane	5~11mV in 1800ppm	
Standard test conditions	Test gas conditions	Hydrogen/methane/iso-butane in air at 20±2°C, 65±5%RH		
	Circuit conditions	3.0±0.05V AC/DC		
	Preheating period before test	≥10 min.		
Operating conditions		-10°C~+70°C, ≤95%RH (w/o dew condensation)		
Storage conditions		-10°C~+80°C, ≤95%RH (w/o dew condensation)		

Structure and Dimensions:

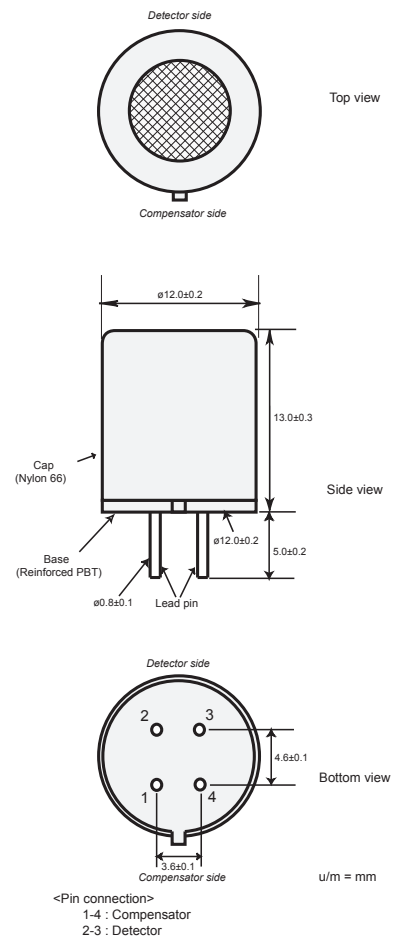

All sensor characteristics shown in this brochure represent typical characteristics. Actual characteristics vary from sensor to sensor. The only characteristics warranted are those in the Specification table above.

FIGARO ENGINEERING INC.
 1-5-11 Senba-nishi
 Mino, Osaka 562-8505 JAPAN
 Phone: (81)-72-728-2045
 www.figaro.co.jp
 email: figaro@figaro.co.jp