

THIS DRAWING IS UNPUBLISHED. RELEASED FOR PUBLICATION 20
 © COPYRIGHT 20 BY - ALL RIGHTS RESERVED.

REVISIONS				
P	LTR	DESCRIPTION	DATE	APVD
P9		REVISED PER ECR-18-010208	24JUL2018	BDA SF
P10		REVISED PER ECO-19-012876	21AUG2019	BKW SF

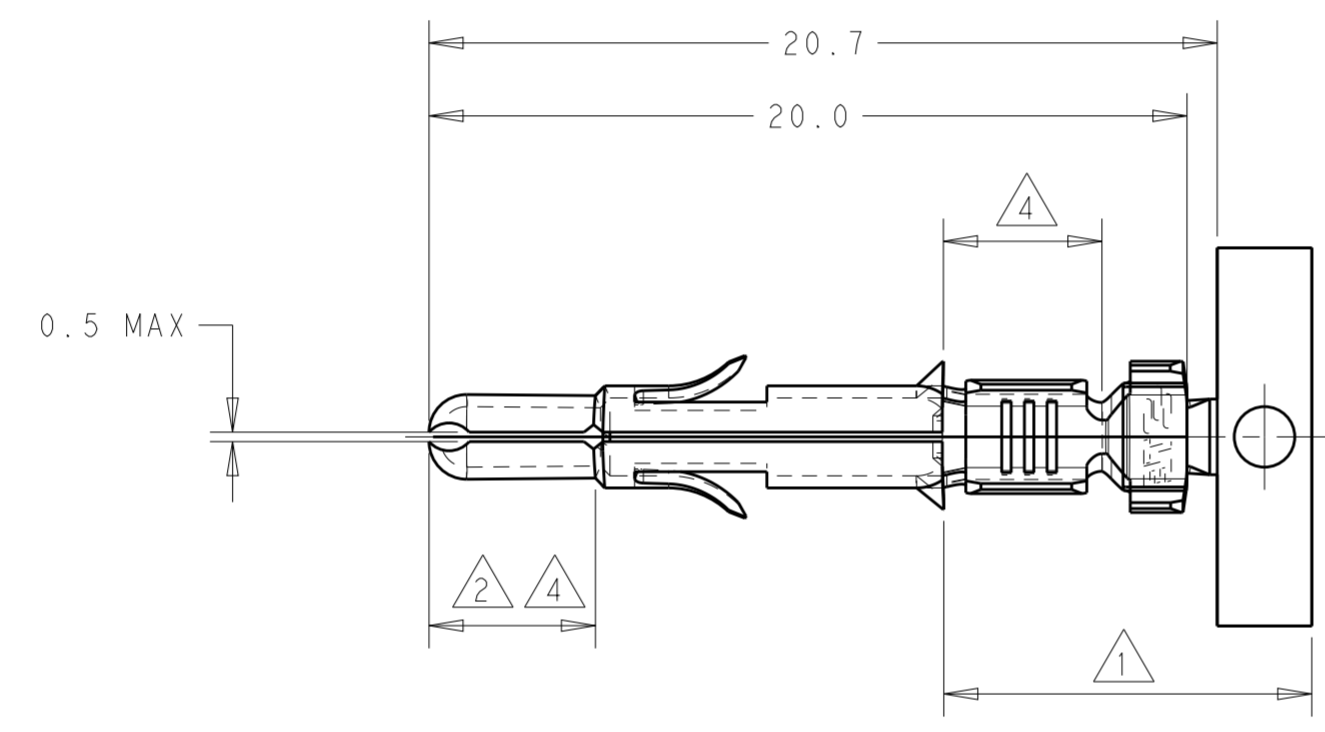
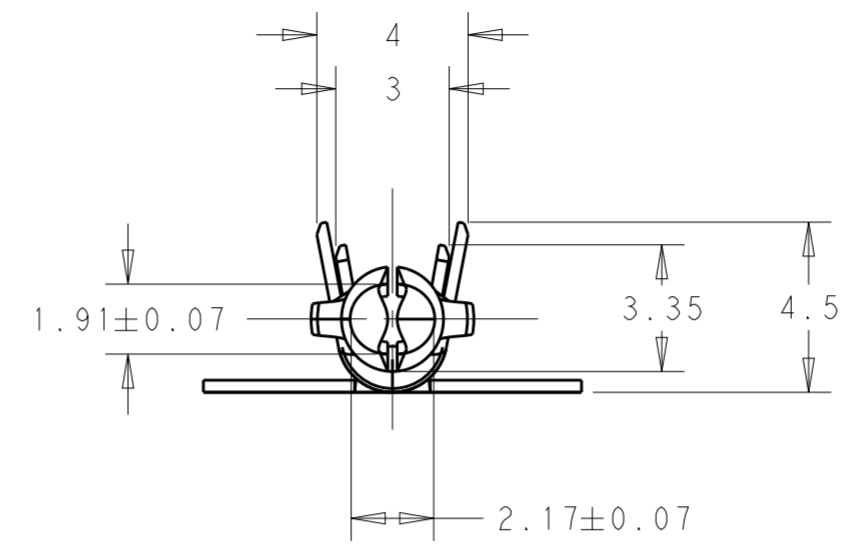
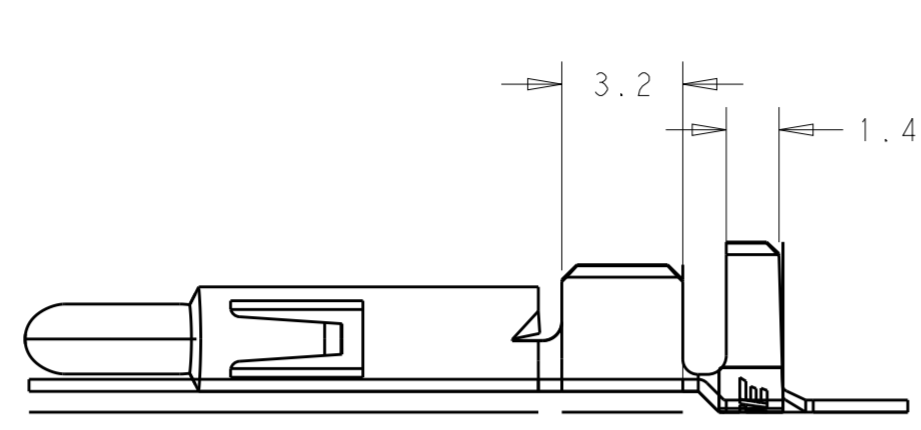

- 1 2-6 μm TIN OVER NICKEL IN CRIMP AREA
2-6 μm Sn UBER NI IN DER CRIMPZONE
- 2 0.8 μm GOLD OVER NICKEL IN THE CONTACT ZONE
0.8 μm Au UBER NI IN DER KONTAKTZONE
- 3. FOR INSULATIONS Ø 1.5-3.3 mm
FUR ISOLATIONS Ø 1.5-3.3mm GEELGNET
- 4 0.8 μm GOLD OVER 1.3 μm NICKEL ON INSIDE OF
WIRE BARREL AND THE CONTACT ZONE. OTHERWISE 1.3 μm NI
0.8 μm Au UBER 1.3 μm Ni IN DEN DRAHTCRIMP
UND KONTAKTZONEN, SORST 1.3 μm NI
- 5 DIRECTION OFF TOP OF REEL

6 OBSOLETE PARTS: OBSOLETE CIS
STREAMLINING PER D.RENAUD/D.SINISI

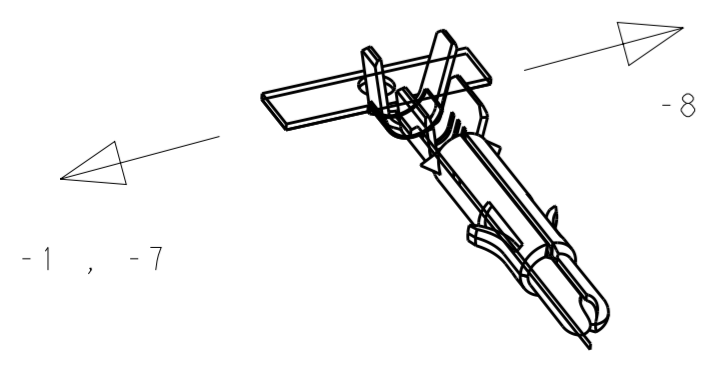

6	OBSELETE	-	926887-8	BRASS	5 PRETINNED
			926898-7	BRASS	1 2
	SUPERSEDED BY 350687-6		926898-6	PHOS BRONZE	1 2
6	OBSELETE	926898-5	926887-5	COPPER ALLOY	PRETINNED
	OBSELETE	926898-4	926887-4	COPPER ALLOY	NONE
		926898-3	926887-3	PHOS BRONZE	PRETINNED
6	OBSELETE	926898-2	926887-2	BRASS	4
		926898-1	926887-1	BRASS	PRETINNED
		LOOSE PIECE	PART-NUMBER	MATERIAL	PLATING/FINISH

THIS DRAWING IS A CONTROLLED DOCUMENT.

DIMENSIONS: mm	TOLERANCES UNLESS OTHERWISE SPECIFIED: 0 PLC ± 1 PLC ±0.2 2 PLC ± 3 PLC ± 4 PLC ± ANGLES ± FINISH	DWN R. SMITH 22FEB2017 CHK K. RANDOLPH 22FEB2017 APVD K. RANDOLPH 22FEB2017	TE Connectivity	
MATERIAL SEE TABLE	SEE TABLE	PRODUCT SPEC 108-1031	NAME UNIVERSAL M-N-L STIFT DGB 0.5-2.1 mm ²	
		APPLICATION SPEC 114-1010	SIZE A2	RESTRICTED TO -
		WEIGHT -	CAGE CODE -	DRAWING NO G-926887
CUSTOMER DRAWING		SCALE 5:1	SHEET 1 OF 1	REV P10