

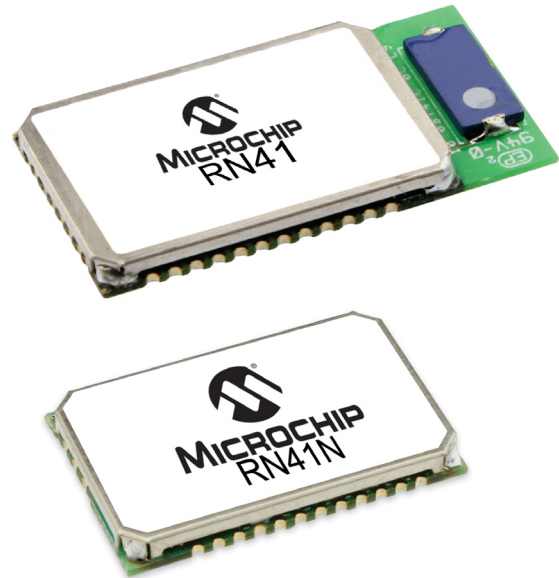
---

## Class 1 Bluetooth® Module with EDR Support

---

### Features

- Fully qualified Bluetooth® version 2.1 module, supports version 2.1 + Enhanced Data Rate (EDR)
- ASCII command interface over UART
- Postage-stamp sized form factor:
  - RN41: 13.4 mm x 25.8 mm x 2 mm
  - RN41N: 13.4 mm x 20 mm x 2 mm
- Low-power (30 mA connected, < 10 mA sniff mode)
- UART (SPP or HCI) and USB (HCI only) data connection interfaces
- Sustained SPP data rates: 240 Kbps (Peripheral mode), 300 Kbps (Central mode)
- HCI data rates: 1.5 Mbps sustained, 3.0 Mbps burst in HCI mode
- Embedded Bluetooth stack profiles include: GAP, SDP, RFCOMM, L2CAP protocols, with SPP, HID and DUN profile support (does not require any host stack).
- Bluetooth SIG qualified, end product listing
- Castellated SMT pads for easy and reliable PCB mounting
- Class 1 high-power amplifier with on-board ceramic chip antenna (RN41) or external antenna (RN41N)
- Compliance:
  - Modular Certified for the United States (FCC) and Canada (ISED)
  - European RED Assessed Radio Module
  - Australia/New Zealand/Korea/Taiwan/Japan
  - Bluetooth SIG QDID
- Integrated Crystal, Internal Voltage Regulator, Matching Circuitry, Power Amplifier, Low Noise, Memory Amplifier and PCB Antenna
- Easy Integration into Final Product - Minimize Product Development, Quicker Time to Market
- Compatible with Microchip Microcontroller Families (PIC16F, PIC18F, PIC24F/H, dsPIC33 and PIC32)
- Up to 100 meter range



### Applications

- Cable replacement
- Barcode scanners
- Measurement and monitoring systems
- Industrial sensors and controls
- Medical devices

# RN41/RN41N

---

---

RN41/RN41 MODULE VARIANTS <sup>(1)</sup>			
Model	Antenna	Firmware	Description
RN41	Ceramic Chip	4.77, 6.15	Class 1, 2.1+EDR, SPP profile
RN41HCI	Ceramic Chip	N/A	Class 1, 2.0+EDR, HCI over UART
RN41U	Ceramic Chip	N/A	Class 1, 2.0+EDR, HCI over USB
RN41HID	Ceramic Chip	6.11	Class 1, 2.1+EDR, HID and SPP profiles
RN41APL	Ceramic Chip	5.36, 5.43, 5.45	Class 1, 2.1+EDR, SPP & MFi profiles
RN41N	External	4.77, 6.15	Class 1, 2.1+EDR, SPP profile
RN41NAPL	External	5.36, 5.43, 5.45	Class 1, 2.1+EDR, SPP and MFi profiles

**Note:** See **Section 4.0 “Ordering Information”** for customer part numbers. Information on firmware versions can be found on the RN41/RN41N product web page and the *“Bluetooth Data Module Command Reference and Advanced Information User’s Guide”*.

## Table of Contents

1.0 Device Overview .....	4
2.0 Application Information .....	8
3.0 Regulatory Approval .....	13
4.0 Ordering Information.....	19
Appendix A: Revision History .....	21
Product Identification System .....	23
The Microchip Web Site.....	25
Customer Change Notification Service.....	25
Customer Support .....	25

### TO OUR VALUED CUSTOMERS

It is our intention to provide our valued customers with the best documentation possible to ensure successful use of your Microchip products. To this end, we will continue to improve our publications to better suit your needs. Our publications will be refined and enhanced as new volumes and updates are introduced.

If you have any questions or comments regarding this publication, please contact the Marketing Communications Department via E-mail at [docerrors@microchip.com](mailto:docerrors@microchip.com). We welcome your feedback.

#### Most Current Data Sheet

To obtain the most up-to-date version of this data sheet, please register at our website at:

<http://www.microchip.com>

You can determine the version of a data sheet by examining its literature number found on the bottom outside corner of any page. The last character of the literature number is the version number, (e.g., DS30000000A is version A of document DS30000000).

#### Errata

An errata sheet, describing minor operational differences from the data sheet and recommended workarounds, may exist for current devices. As device/documentation issues become known to us, we will publish an errata sheet. The errata will specify the revision of silicon and revision of document to which it applies.

To determine if an errata sheet exists for a particular device, please check with one of the following:

- Microchip's Worldwide Web site: <http://www.microchip.com>
- Your local Microchip sales office (see last page)

When contacting a sales office, please specify which device, revision of silicon and data sheet (include literature number) you are using.

#### Customer Notification System

Register on our web site at [www.microchip.com](http://www.microchip.com) to receive the most current information on all of our products.

# RN41/RN41N

## 1.0 DEVICE OVERVIEW

The RN41/RN41N module is a small form factor, low-power, class 1 Bluetooth radio that is ideal for designers who want to add wireless capability to their products without spending significant time and money developing Bluetooth-specific hardware and software. The RN41/RN41N supports multiple interface protocols, is simple to design in and is fully certified, making it a complete embedded Bluetooth solution. With its high-performance, chip antenna (RN41) or external antenna (RN41N) and support for Bluetooth EDR, the RN41/RN41N delivers up to a 3-Mbps data rate for distances up to 100 meters.

### 1.1 MCU Interface

The RN41/RN41N module is managed through ASCII commands via the UART and/or PIO signals. A MCU (micro-controller-unit) or host processor sends commands to module to configure features, read status and manage Bluetooth data connections.

As shown in Figure 1-1, the UART TX and RX are required to communicate with module and transfer data across Bluetooth SPP connection.

Connecting the hardware flow control lines CTS and RTS is highly recommended for applications that transmits a continuous stream of data.

The module can be configured locally via the UART or over-the-air. To support instant cable replacement, auto-discovery/pairing does not require software configuration. Additionally, the module supports auto-connect central, I/O pin (DTR) and character-based trigger modes.

FIGURE 1-1: RN41/RN41N TO MCU INTERFACE

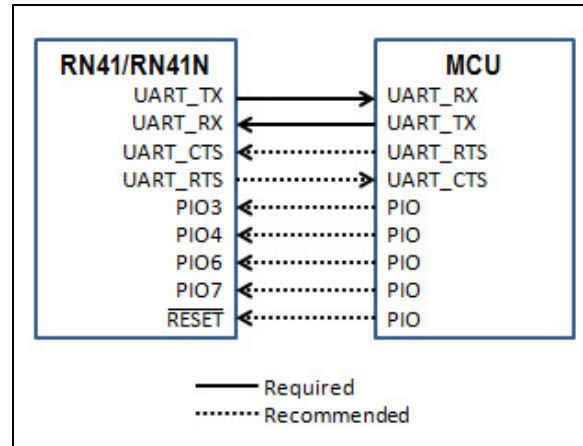


Table 1-1, Table 1-2, Table 1-3, Table 1-4 and Table 1-5 provide the module's environmental conditions, electrical characteristics, dimensions, radio characteristics and digital I/O characteristics.

### 1.2 ASCII Command and Data Interface

The "Bluetooth Data Module Command Reference and Advanced Information User's Guide" provides a complete description of the ASCII command and data interface for the RN41/RN41N module.

TABLE 1-1: ENVIRONMENTAL CONDITIONS

Parameter	Value
Temperature Range (Operating)	-40° C ~ 85° C
Temperature Range (Storage)	-40° C ~ 85° C
Relative Humidity (Operating)	≤ 90%
Relative Humidity (Storage)	≤ 90%
Moisture Sensitivity Level	3

TABLE 1-2: ELECTRICAL CHARACTERISTICS

Parameter	Min.	Typ.	Max.	Units
Supply Voltage (DC)	3.0	3.3	3.6	V
RX Supply Current	—	35	60	mA
TX Supply Current	—	65	100	mA
<b>Average Power Consumption</b>				
Standby/Idle (Default Settings)	—	25	—	mA
Connected (Normal Mode)	—	30	—	mA
Connected (Low-Power Sniff)	—	8	—	mA
Standby/Idle (Deep Sleep Enabled)	250	2.5	—	mA

**TABLE 1-3: MODULE DIMENSIONS**

Parameter	RN41	RN41N	Units
Size	13.4 x 25.8 x 2	13.4 x 20 x 2	mm
Weight	0.045	0.040	oz.

**TABLE 1-4: RADIO CHARACTERISTICS**

Parameter	Frequency (GHz)	Min.	Typ.	Max.	Bluetooth Specification	Units
Sensitivity at 0.1% BER	2.402	—	-80	-86	≤ -70	dBm
	2.441	—	-80	-86		dBm
	2.480	—	-80	-86		dBm
RF Transmit Power <sup>(1)</sup> RN41	2.402	—	16.3	—	—	dBm
	2.441	—	17.0	—		dBm
	2.480	—	18.4	—		dBm
RF Transmit Power <sup>(1)</sup> RN41N	2.402	—	11.9	—	—	dBm
	2.441	—	10.9	—		dBm
	2.480	—	9.9	—		dBm
Initial Carrier Frequency Tolerance	2.402	—	5	75	75	kHz
	2.441	—	5	75		kHz
	2.480	—	5	75		kHz
20-dB Bandwidth for Modulated Carrier	—	—	900	1000	≤ 1000	kHz
Drift (Five Slots Packet)	—	—	15	—	40	kHz
Drift Rate	—	—	13	—	20	kHz
$\Delta f_{1\text{avg}}$ Maximum Modulation	2.402	140	165	175	> 140	kHz
	2.441	140	165	175		kHz
	2.480	140	165	175		kHz
$\Delta f_{2\text{avg}}$ Minimum Modulation	2.402	140	190	—	115	kHz
	2.441	140	190	—		kHz
	2.480	140	190	—		kHz

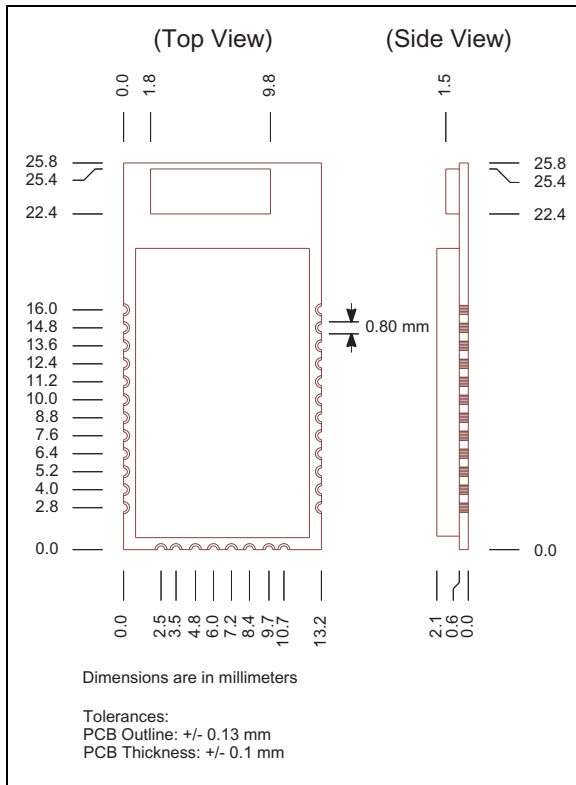
**TABLE 1-5: DIGITAL I/O CHARACTERISTICS**

$3.0\text{ V} \leq \text{VDD} \leq 3.3\text{ V}$	Min.	Typ.	Max.	Units
Input Logic Level Low	-0.4	—	+0.8	V
Input Logic Level High	0.7 VDD	—	VDD + 0.4	V
Output Logic Level Low	—	—	0.2	V
Output Logic Level High	VDD - 0.2	—	—	V
All I/O pins (Except reset) Default to Weak Pull Down	+0.2	+1.0	+5.0	μA

# RN41/RN41N

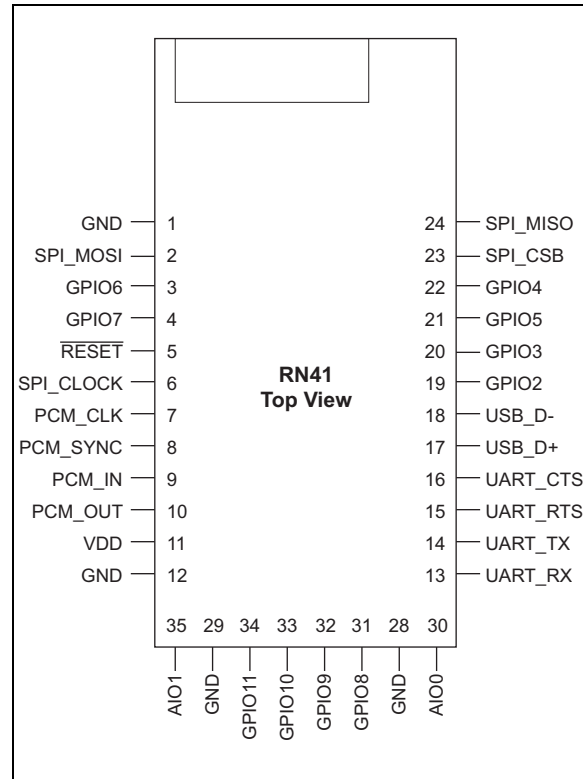
The following figures show the modules' dimensions.

**FIGURE 1-2: RN41 MODULE DIMENSIONS**

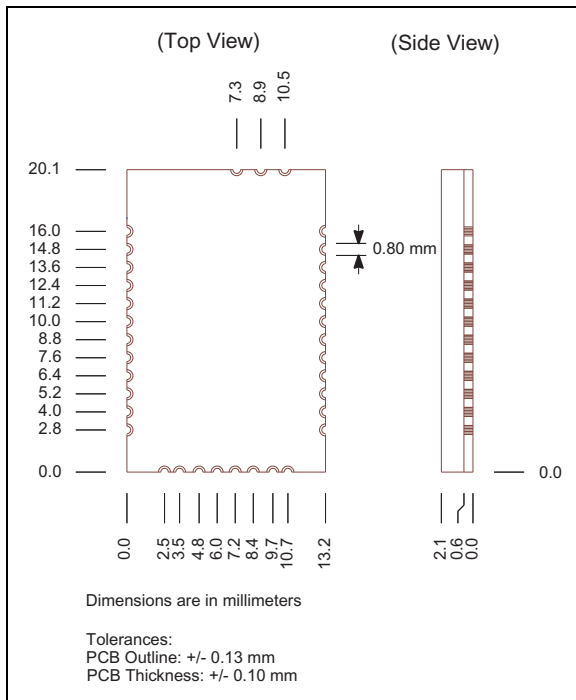


The following figures show the pinout and  
The following table describes the module's pins.

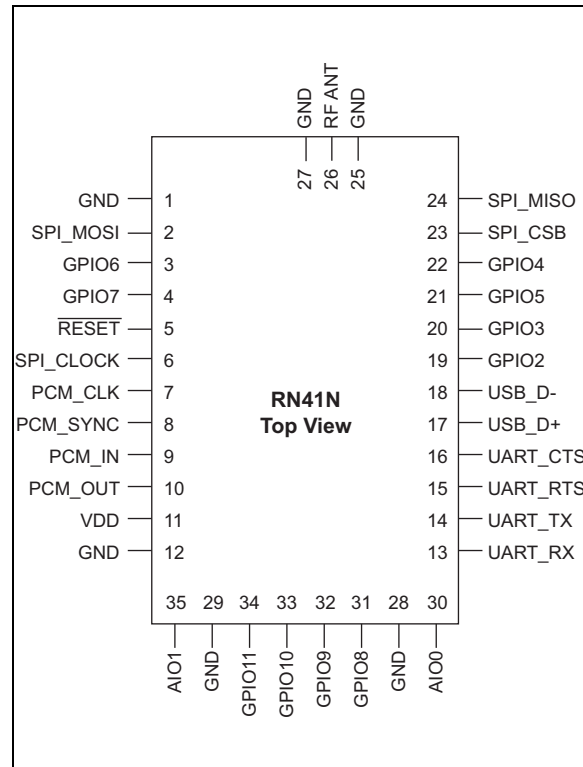
**FIGURE 1-4: RN41 PIN DIAGRAM**



**FIGURE 1-3: RN41N MODULE DIMENSIONS**



**FIGURE 1-5: RN41N PIN DIAGRAM**



**TABLE 1-6: PIN DESCRIPTION**

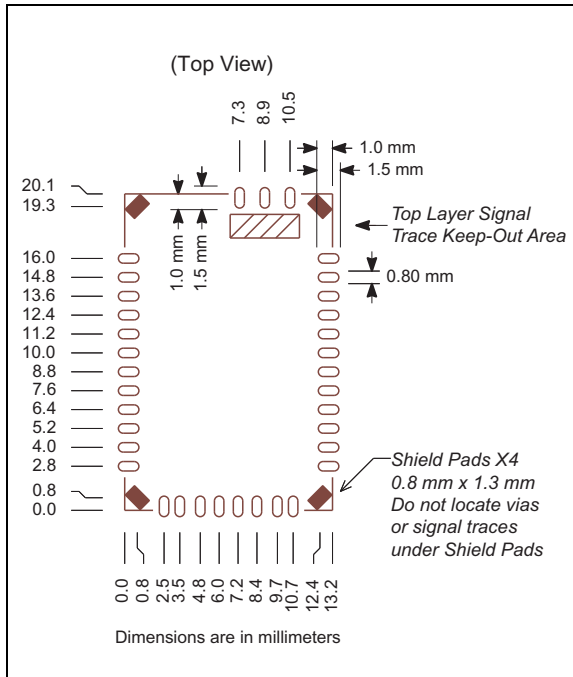
Pin	Symbol	Type	Description
1	GND	Power	Ground reference
2	SPI_MOSI	DI	(Optional) Factory diagnostic and test. See <b>Section 2.8 “SPI Interface”</b> .
3	GPIO6	DIO	Set Bluetooth central (high = auto-central mode)
4	GPIO7	DIO	Set baud rate (high = force 9,600, low = 115K or firmware setting)
5	RESET	DI	Active-low Reset
6	SPI_CLK	DI	(Optional) Factory diagnostic and test. See <b>Section 2.8 “SPI Interface”</b> .
7	PCM_CLK	DIO	(Do not connect) PCM interface <sup>(1)</sup>
8	PCM_SYNC	DIO	(Do not connect) PCM interface <sup>(1)</sup>
9	PCM_IN	DI	(Do not connect) PCM interface <sup>(1)</sup>
10	PCM_OUT	DO	(Do not connect) PCM interface <sup>(1)</sup>
11	VDD	Power	Positive Supply
12	GND	Power	Ground reference
13	UART_RX	DI	UART receive input
14	UART_TX	DO	UART transmit output
15	UART_RTS	DO	UART RTS, goes high to disable host transmitter
16	UART_CTS	DI	UART CTS, if set high, it disables transmitter
17	USB_D+	DIO	USB port. 1.5K pullup activated when USB port is ready (~500 ms after reset).
18	USB_D-	DIO	USB port
19	GPIO2	DIO	Status, high when connected, low otherwise. See <b>Section 2.3 “Connection Status”</b> .
20	GPIO3	DIO	Auto discovery = high
21	GPIO5	DIO	Status, toggles based on state, low on connect. See <b>Section 2.3 “Connection Status”</b> .
22	GPIO4	DIO	Set factory defaults. See <b>Section 2.2 “Factory Reset Using GPIO4”</b> .
23	SPI_CSB	DI	(Optional) Factory diagnostic and test. See <b>Section 2.8 “SPI Interface”</b> .
24	SPI_MISO	DO	(Optional) Factory diagnostic and test. See <b>Section 2.8 “SPI Interface”</b> .
25	GND	Power	Ground reference (RN41N only)
26	RF ANT	AIO	Antenna, 50-Ohm impedance (RN41N only)
27	GND	Power	Ground reference (RN41N only)
28	GND	Power	Ground reference
29	GND	Power	Ground reference
30	AIO0	AIO	(Not used) Optional analog input.
31	GPIO8	DIO	UART TX/RX data activity
32	GPIO9	DIO	I/O
33	GPIO10	DIO	I/O (remote DTR signal)
34	GPIO11	DIO	I/O (remote RTS signal)
35	AIO1	AIO	(Not used) Optional analog input

**Note 1:** Pin numbers 7 through 10 are reserved for future use.

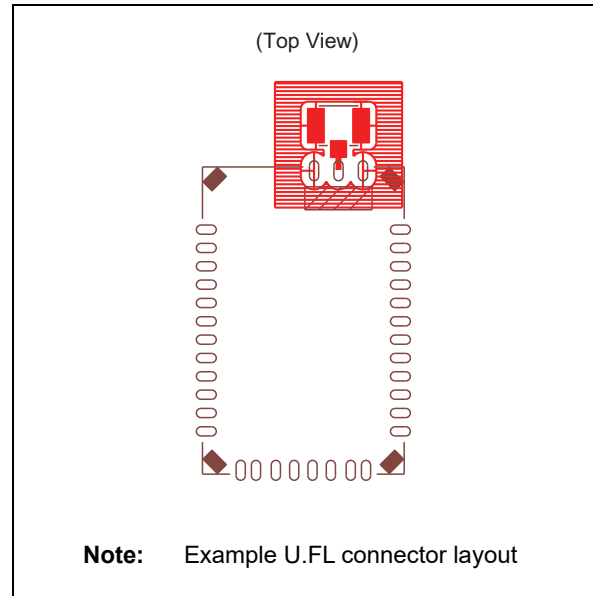




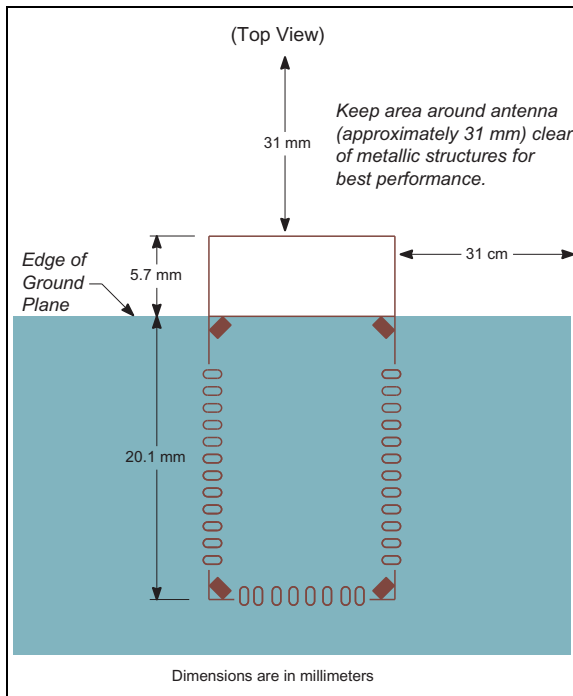
**FIGURE 2-2: RN41N RECOMMENDED PCB FOOTPRINT**



**FIGURE 2-4: RN41N MODULE MOUNTING DETAILS**

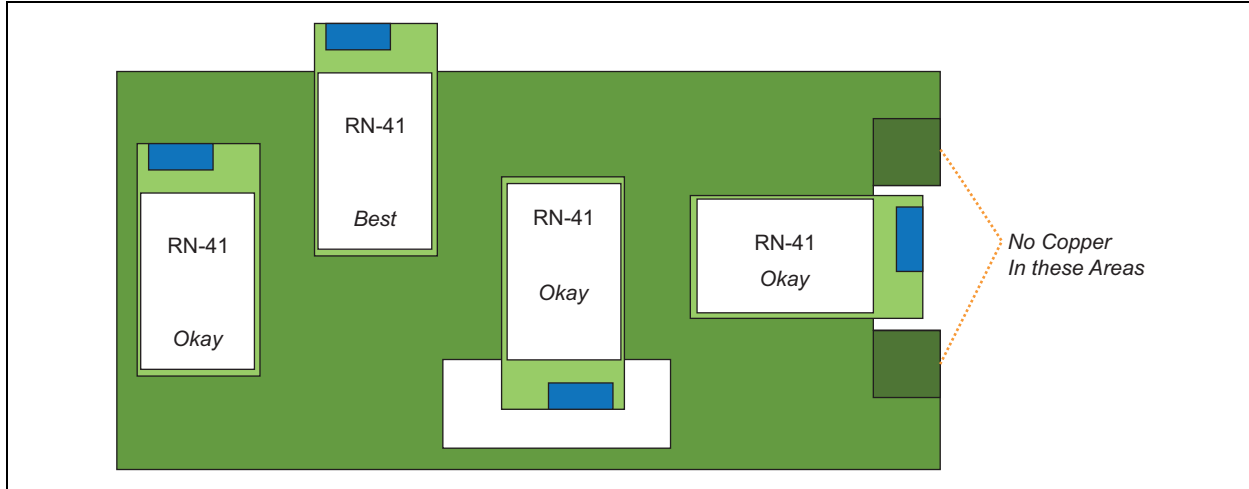


**FIGURE 2-3: RN41 MODULE MOUNTING DETAILS**



# RN41/RN41N

**FIGURE 2-5: RN41 HOST PCB EXAMPLE LAYOUT**



## 2.5 External Antenna Types (RN41N)

The RN41N module's antenna pin (pin 25) provides a 50-ohm impedance to external antennas. Pin 25 can connect directly to a coaxial cable or to an antenna connector such as a U.FL or reverse polarity SMA.

The PCB trace from pin 25 to the coaxial cable or connector should be less than 0.2 inches (5 mm) for minimum loss and the best impedance match. If the PCB trace is longer, it should be a 50-ohm impedance microstrip trace. Connect adjacent ground pins 24 and 26 to a low-impedance ground on the host PCB and the antenna connection. [Figure 2-4](#) gives example host PCB layout to a U.FL connector.

Modular certification of the RN41N module was performed with the external antenna types listed in the following table. Refer to **Section 3.0 "Regulatory Approval"** for specific regulatory requirements by country.

**TABLE 2-3: TESTED EXTERNAL ANTENNA TYPES**

Type	Gain (dBi)
Monopole	0.56
Whip	8
Yagi	15

## 2.6 HCI Mode

Microchip offers the Host Controller Interface (HCI) mode in addition to the standard operational mode of its Bluetooth modules (standard mode refers to the on-board stack running on the module).

In HCI mode, the on-board stack is bypassed and the module is put in a state that runs the Bluetooth baseband. The HCI provides a command reference interface to the baseband controller and the link manager, and provides access to the hardware status and control registers. This interface provides a uniform method for accessing the Bluetooth baseband capabilities.

In this mode, the Bluetooth stack is no longer on-board the module. It is offloaded to the interfacing host processor. The Bluetooth module is used as a radio, performing the lower level MAC functionalities, while the application stack runs on the host processor.

Using the module in HCI mode enables designers to implement profiles that are not natively supported on the Bluetooth module.

**Note:** HCI mode is only available by ordering part RN41HCI for UART interface; or RN41U for USB interface.

Microchip offers HCI mode in two hardware interfaces:

- HCI over UART (RN41HCI-I/RM)
- HCI over USB (RN41U-I/RM)

## 2.6.1 HCI OVER UART

In this mode, the hardware interface between the host processor and the Bluetooth module is the UART configured at 115.2 Kbps. You must interface the flow control signals between the host processor and the Bluetooth module for the HCI interface to work. Failure to do so can cause the host processor and the Bluetooth module to become out of sync and break the Bluetooth link.

## 2.6.2 HCI OVER USB

In this mode, the hardware interface between the host processor and the Bluetooth module is the USB. In this architecture, the Bluetooth module is the USB client and the host processor is the USB host.

Using the USB interface offers the advantage of a faster data link between the Bluetooth module and the host processor. With this architecture, it is possible to achieve Bluetooth's theoretical maximum throughput of 3 Mbps.

## 2.7 Soldering Recommendations

The RN41/RN41N wireless module was assembled using standard lead-free reflow profile IPC/JEDEC J-STD-020.

The module can be soldered to the host PCB using standard leaded and lead-free solder reflow profiles.

To avoid damaging the module, the following recommendations are given:

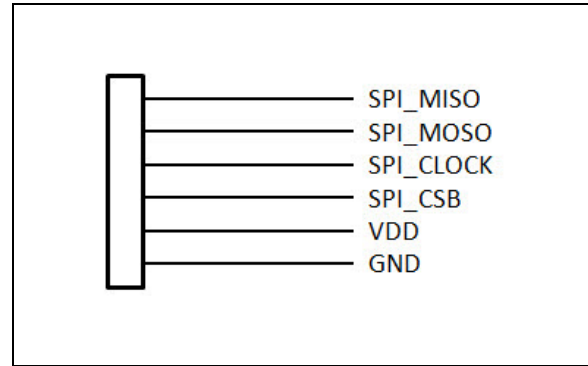
- Microchip Technology Application Note, "AN233 Solder Reflow Recommendation" (DS00233) provides solder reflow recommendations
- Do not exceed peak temperature ( $T_p$ ) of 250 C°
- Refer to the solder paste data sheet for specific reflow profile recommendations
- Use no-clean flux solder paste
- Do not wash as moisture can be trapped under the shield
- Use only one flow. If the PCB requires multiple flows, apply the module on the final flow.

## 2.8 SPI Interface

The SPI Interface is primarily used for factory test and diagnostics. Although not required, the SPI interface is useful for restoring a corrupted flash image or enabling test modes required for certification testing.

When module is installed in a final product that requires European type approval, see **Section 3.3 "Europe"**, it is recommended that the SPI interface should be accessible via 6-pin header as shown in the following figure.

**FIGURE 2-6: OPTIONAL SPI INTERFACE**



## 2.9 Bluetooth SIG QDID

The RN41 has a QDID registered with the Bluetooth SIG. The manufacturer using the RN41 module in their end product can reference this QDID when filing an EPL (end product listing) to use the Bluetooth® brand and logo. Please visit the Bluetooth SIG at [www.bluetooth.org](http://www.bluetooth.org) for more information.

Declaration ID: B013180

QDID: 7786



## 3.0 REGULATORY APPROVAL

This section outlines the regulatory information for the RN41/RN41N module for the following countries:

- United States
- Canada
- Europe
- Australia
- New Zealand

### 3.1 United States

The RN41/RN41N module has received Federal Communications Commission (FCC) CFR47 Telecommunications, Part 15 Subpart C "Intentional Radiators" modular approval in accordance with Part 15.212 Modular Transmitter approval. Modular approval allows the end user to integrate the RN41/RN41N module into a finished product without obtaining subsequent and separate FCC approvals for intentional radiation, provided no changes or modifications are made to the module circuitry. Changes or modifications could void the user's authority to operate the equipment. The end user must comply with all of the instructions provided by the Grantee, which indicate installation and/or operating conditions necessary for compliance.

The finished product is required to comply with all applicable FCC equipment authorizations regulations, requirements and equipment functions not associated with the transmitter module portion. For example, compliance must be demonstrated to regulations for other transmitter components within the host product; to requirements for unintentional radiators (Part 15 Subpart B "Unintentional Radiators"), such as digital devices, computer peripherals, radio receivers, etc.; and to additional authorization requirements for the non-transmitter functions on the transmitter module (i.e., Verification, or Declaration of Conformity) (e.g., transmitter modules may also contain digital logic functions) as appropriate.

### 3.1.1 LABELING AND USER INFORMATION REQUIREMENTS

The RN41/RN41N module has been labeled with its own FCC ID number and if the FCC ID is not visible when the module is installed inside another device, then the outside of the finished product into which the module is installed must also display a label referring to the enclosed module. This exterior label can use wording as follows:

**RN41:**

Contains Transmitter Module FCC ID: T9JRN41-3

*or*

Contains FCC ID: T9JRN41-3

This device complies with Part 15 of the FCC Rules. Operation is subject to the following two conditions: (1) this device may not cause harmful interference and (2) this device must accept any interference received, including interference that may cause undesired operation

**RN41N:**

Contains Transmitter Module FCC ID: OA3-RN41N

*or*

Contains FCC ID: OA3-RN41N

This device complies with Part 15 of the FCC Rules. Operation is subject to the following two conditions: (1) this device may not cause harmful interference and (2) this device must accept any interference received, including interference that may cause undesired operation

# RN41/RN41N

---

A user's manual for the product should include the following statement:

This equipment has been tested and found to comply with the limits for a Class B digital device, pursuant to part 15 of the FCC Rules. These limits are designed to provide reasonable protection against harmful interference in a residential installation. This equipment generates, uses and can radiate radio frequency energy and, if not installed and used in accordance with the instructions, may cause harmful interference to radio communications. However, there is no guarantee that interference will not occur in a particular installation. If this equipment does cause harmful interference to radio or television reception, which can be determined by turning the equipment off and on, the user is encouraged to try to correct the interference by one or more of the following measures:

- Reorient or relocate the receiving antenna.
- Increase the separation between the equipment and receiver.
- Connect the equipment into an outlet on a circuit different from that to which the receiver is connected.
- Consult the dealer or an experienced radio/TV technician for help.

Additional information on labeling and user information requirements for Part 15 devices can be found in KDB Publication 784748 available at the FCC Office of Engineering and Technology (OET) Laboratory Division Knowledge Database (KDB) <https://apps.fcc.gov/oetcf/kdb/index.cfm>.

## 3.1.2 RF EXPOSURE

All transmitters regulated by FCC must comply with RF exposure requirements. KDB 447498 General RF Exposure Guidance provides guidance in determining whether proposed or existing transmitting facilities, operations or devices comply with limits for human exposure to Radio Frequency (RF) fields adopted by the Federal Communications Commission (FCC).

From the RN41 FCC Grant: Modular Approval. Power Output listed is conducted. The antenna(s) used for this device must be installed to provide a separation distance of at least 20 cm from all persons and must not be co-located or operating in conjunction with any other antenna or transmitter. This grant is valid only when the device is sold to OEM integrators and the OEM integrators are instructed to ensure that the end user has no manual instructions to remove or install the device. End users and installers must be provided with antenna installation instructions and transmitter operating conditions for satisfying RF Exposure compliance.

From the RN41N FCC Grant: Modular Approval. Power Output listed is conducted. The antenna(s) used for this device must be installed to provide a separation distance of at least 20 cm from all persons and must not be co-located or operating in conjunction with any other antenna or transmitter. This grant is valid only when the device is sold to OEM integrators and the OEM integrators are instructed to ensure that the end user has no manual instructions to remove or install the device. End users and installers must be provided with antenna installation instructions and transmitter operating conditions for satisfying RF Exposure compliance.

If the RN41/RN41N module is used in a portable application (i.e., the antenna is less than 20 cm from persons during operation), the integrator is responsible for performing Specific Absorption Rate (SAR) testing in accordance with the guidance in KDB 447498.

## 3.1.3 APPROVED EXTERNAL ANTENNA TYPES

To maintain modular approval in the United States, only the antenna types that have been tested shall be used. It is permissible to use different antenna manufacturer provided the same antenna type and antenna gain (equal to or less than) is used.

Testing of the RN41N module was performed with the antenna types listed in [Table 2-3](#).

## 3.1.4 HELPFUL WEB SITES

Federal Communications Commission (FCC): <http://www.fcc.gov>

FCC Office of Engineering and Technology (OET) Laboratory Division Knowledge Database (KDB): <https://apps.fcc.gov/oetcf/kdb/index.cfm>.

## 3.2 Canada

The RN41/RN41N module has been certified for use in Canada under Innovation, Science and Economic Development Canada (ISED, formerly Industry Canada) Radio Standards Specification (RSS) RSS-210 and RSSGen. Modular approval permits the installation of a module in a host device without the need to recertify the device.

## 3.2.1 LABELING AND USER INFORMATION REQUIREMENTS

Labeling Requirements for the Host Device (from RSP-100, Issue 12, Section 5): The host device shall be properly labeled to identify the module within the host device.

The Industry Canada certification label of a module shall be clearly visible at all times when installed in the host device, otherwise the host device must be labeled to display the Industry Canada certification number of the module, preceded by the words "Contains transmitter module", or the word "Contains", or similar wording expressing the same meaning, as follows:

**RN-41:**

Contains transmitter module IC: 6514A-RN413

**RN-41N:**

Contains transmitter module IC: 7693A-RN41N

User Manual Notice for License-Exempt Radio Apparatus (from Section 8.4 RSS-Gen, Issue 5, March 2019): User manuals for license-exempt radio apparatus shall contain the following or equivalent notice in a conspicuous location in the user manual or alternatively on the device or both:

This device contains license-exempt transmitter(s)/ receiver(s) that comply with Innovation, Science and Economic Development Canada's license-exempt RSS(s). Operation is subject to the following two conditions:

1. This device may not cause interference;
2. This device must accept any interference, including interference that may cause undesired operation of the device.

L'émetteur/récepteur exempt de licence contenu dans le présent appareil est conforme aux CNR d'Innovation, Sciences et Développement économique Canada applicables aux appareils radio exempts de licence. L'exploitation est autorisée aux deux conditions suivantes:

1. L'appareil ne doit pas produire de brouillage;
2. L'appareil doit accepter tout brouillage radioélectrique subi, même si le brouillage est susceptible d'en compromettre le fonctionnement.

Transmitter Antenna (From Section 6.8 RSS-GEN, Issue 5, March 2019): User manuals, for transmitters shall display the following notice in a conspicuous location:

This radio transmitter [IC: 6514A-RN413 and IC: 7693A-RN41N] has been approved by Innovation, Science and Economic Development Canada to operate with the antenna types listed below, with the maximum permissible gain indicated. Antenna types not included in this list that have a gain greater than the maximum gain indicated for any type listed are strictly prohibited for use with this device.

Le présent émetteur radio [IC: 6514A-RN413 and IC: 7693A-RN41N] a été approuvé par Innovation, Sciences et Développement économique Canada pour fonctionner avec les types d'antenne énumérés cidessous et ayant un gain admissible maximal. Les types d'antenne non inclus dans cette liste, et dont le gain est supérieur au gain maximal indiqué pour tout type figurant sur la liste, sont strictement interdits pour l'exploitation de l'émetteur.

Immediately following the above notice, the manufacturer shall provide a list of all antenna types approved for use with the transmitter, indicating the maximum permissible antenna gain (in dBi) and required impedance for each.

### 3.2.2 RF EXPOSURE

All transmitters regulated by ISED must comply with RF exposure requirements listed in RSS-102 - Radio Frequency (RF) Exposure Compliance of Radiocommunication Apparatus (All Frequency Bands).

### 3.2.3 APPROVED EXTERNAL ANTENNA TYPES

Transmitter Antenna (from Section 7.1.2 RSS-Gen, Issue 3, December 2010):

The RN41N module can only be sold or operated with antennas with which it was approved. Transmitter may be approved with multiple antenna types. An antenna type comprises antennas having similar in-band and out-of-band radiation patterns. Testing shall be performed using the highest gain antenna of each combination of transmitter and antenna type for which approval is being sought, with the transmitter output power set at the maximum level. Any antenna of the same type having equal or lesser gain as an antenna that had been successfully tested with the transmitter, will also be considered approved with the transmitter, and may be used and marketed with the transmitter.

When a measurement at the antenna connector is used to determine RF output power, the effective gain of the device's antenna shall be stated, based on measurement or on data from the antenna manufacturer. For transmitters of output power greater than 10 milliwatts, the total antenna gain shall be added to the measured RF output power to demonstrate compliance to the specified radiated power limits.

# RN41/RN41N

Approved external antenna types for the RN41N module are listed in [Table 2-3](#).

## 3.2.4 HELPFUL WEB SITES

Industry Canada: <http://www.ic.gc.ca/>

## 3.3 Europe

The RN41/41N module is Radio Equipment Directive (RED) assessed, CE marked and have been manufactured and tested with the intention of being integrated into a final product.

The RN41/41N module has been tested to RED 2014/53/EU Essential Requirements mentioned in the following European Compliance table.

**TABLE 3-1: EUROPEAN COMPLIANCE**

Certification	Standards	Article
Safety	EN 62368	3.1a
Health	EN 62311	
Electro Magnetic Compatibility (EMC)	EN 301 489-1	3.1b
	EN 301 489-17	
Radio	EN300 328	3.2

The ETSI provides guidance on modular devices in “*Guide to the application of harmonised standards covering Article 3.1b and Article 3.2 of the Directive 2014/53/EU RED to multi-radio and combined radio and non-radio equipment*” document available at [http://www.etsi.org/deliver/etsi\\_eg/203300\\_203399/203367/01.01.01\\_60/eg\\_203367v010101p.pdf](http://www.etsi.org/deliver/etsi_eg/203300_203399/203367/01.01.01_60/eg_203367v010101p.pdf).

**Note:** To maintain conformance to the standards listed in the preceding European Compliance table, the module shall be installed in accordance with the installation instructions in this data sheet and shall not be modified. When integrating a radio module into a completed product, the integrator becomes the manufacturer of the final product and is therefore responsible for demonstrating compliance of the final product with the essential requirements against the RED.

### 3.3.1 LABELING AND USER INFORMATION REQUIREMENTS

The label on the final product which contains the RN41/41N module must follow CE marking requirements.

### 3.3.2 CONFORMITY ASSESSMENT

From ETSI Guidance Note EG 203367, section 6.1 Non-radio products are combined with a radio product:

If the manufacturer of the combined equipment installs the radio product in a host non-radio product in equivalent assessment conditions (i.e. host equivalent to the

one used for the assessment of the radio product) and according to the installation instructions for the radio product, then no additional assessment of the combined equipment against article 3.2 of the RED is required.

### 3.3.2.1 SIMPLIFIED EU DECLARATION OF CONFORMITY

Hereby, Microchip Technology Inc. declares that the radio equipment type RN41/41N is in compliance with Directive 2014/53/EU.

The full text of the EU declaration of conformity for this product is available at

<https://www.microchip.com/wwwproducts/en/RN41>

(available under *Documents > Certifications*).

### 3.3.3 APPROVED EXTERNAL ANTENNAS

For RN41N, the approval is received using the antenna shown in [Table 2-3](#).

### 3.3.4 HELPFUL WEB SITES

A document that can be used as a starting point in understanding the use of Short Range Devices (SRD) in Europe is the European Radio Communications Committee (ERC) Recommendation 70-03 E, which can be downloaded from the European Radio Communications Committee (ECC) at: <http://www.ecodocdb.dk/>.

Additional helpful web sites are:

- Radio Equipment Directive (2014/53/EU): [https://ec.europa.eu/growth/single-market/european-standards/harmonised-standards/red\\_en](https://ec.europa.eu/growth/single-market/european-standards/harmonised-standards/red_en)
- European Conference of Postal and Telecommunications Administrations (CEPT): <http://www.cept.org>
- European Telecommunications Standards Institute (ETSI): <http://www.etsi.org>

The Radio Equipment Directive Compliance Association (REDCA): <http://www.redca.eu/>



## 3.4 Australia

The Australia radio regulations do not provide a modular approval policy similar to the United States (FCC) and Canada (ISED). However, RN41/RN41N module RF transmitter test reports can be used in part to demonstrate compliance in accordance with ACMA Radio communications “Short Range Devices” Standard 2004 (The Short Range Devices standard calls up the AS/NZS 4268:2008 industry standard). The RN41/RN41N module test reports can be used as part of the product certification and compliance folder. For more information on the RF transmitter test reports, contact Microchip Technology Australia sales office.

To meet overall Australian final product compliance, the developer must construct a compliance folder containing all relevant compliance test reports e.g. RF, EMC, electrical safety and DoC (Declaration of Conformity) etc. It is the responsibility of the integrator to know what is required in the compliance folder for ACMA compliance. All test reports are available on the RN41/RN41N product web page at <http://www.microchip.com>. For more information on Australia compliance, refer to the Australian Communications and Media Authority web site <http://www.acma.gov.au/>.

### 3.4.1 EXTERNAL ANTENNA REQUIREMENTS

The compliance testing listed in [Table 3-1](#) was performed using the antenna types listed in [Table 2-3](#).

### 3.4.2 HELPFUL WEB SITES

The Australian Communications and Media Authority: [www.acma.gov.au/](http://www.acma.gov.au/).

## 3.5 New Zealand

The New Zealand radio regulations do not provide a modular approval policy similar to the United States (FCC) and Canada (ISED). However, RN41/RN41N module RF transmitter test reports can be used in part to demonstrate compliance against the New Zealand “General User Radio License for Short Range Devices”. New Zealand Radio communications (Radio Standards) Notice 2010 calls up the AS / NZS 4268:2008 industry standard. The RN41/RN41N module test reports can be used as part of the product certification and compliance folder. All test reports are available on the RN41/RN41N product web page at <http://www.microchip.com>. For more information on the RF transmitter test reports, contact Microchip Technology sales office.

Information on the New Zealand short range devices license can be found in the following web links:

<http://www.rsm.govt.nz/cms/licensees/types-oflicence/general-user-licences/short-range-devices>

and

<http://www.rsm.govt.nz/cms/policy-and-planning/spectrum-policy-overview/legislation/gazette-notices/product-compliance/radiocommunications-radiostandards-notice-2010>.

To meet overall New Zealand final product compliance, the developer must construct a compliance folder containing all relevant compliance test reports e.g. RF, EMC, electrical safety and DoC (Declaration of Conformity) etc. It is the responsibility of the developer to know what is required in the compliance folder for New Zealand Radio communications. For more information on New Zealand compliance, refer to the web site <http://www.rsm.govt.nz/>.

### 3.5.1 EXTERNAL ANTENNA REQUIREMENTS

The compliance testing listed in [Table 3-1](#) was performed using the antenna types listed in [Table 2-3](#).

### 3.5.2 HELPFUL WEB SITES

Radio Spectrum Ministry of Economic Development: <http://www.rsm.govt.nz/>.

## 3.6 UKCA (UK Conformity Assessed)

The RN41/RN41N module is a UK conformity assessed radio module that meets all the essential requirements according to CE RED requirements.

### 3.6.1 LABELING REQUIREMENTS FOR MODULE AND USER'S REQUIREMENTS

The label on the final product that contains the RN41/RN41N module must follow the UKCA marking requirements.



The UKCA mark above is printed on the module itself or on the packing label.

# RN41/RN41N

---

Additional details for the label requirement are available at:

<https://www.gov.uk/guidance/using-the-ukca-marking#check-whether-you-need-to-use-the-new-ukca-marking>.

## 3.6.2 UKCA DECLARATION OF CONFORMITY

Hereby, Microchip Technology Inc. declares that the radio equipment type RN41/RN41N is in compliance with the Radio Equipment Regulations 2017.

The full text of the UKCA declaration of conformity for this product is available (under *Documents* > *Certifications*) at:

- <https://www.microchip.com/en-us/product/RN41>

## 3.6.3 APPROVED ANTENNAS

The testing of the RN41N module was performed with the antennas listed in [Table 2-3](#).

## 3.6.4 HELPFUL WEB SITES

For more information on the UKCA regulatory approvals, refer to the <https://www.gov.uk/guidance/placing-manufactured-goods-on-the-market-in-great-britain>.

## 4.0 ORDERING INFORMATION

Table 4-1 provides ordering information for the RN41/RN41N module.

**TABLE 4-1: ORDERING INFORMATION**

Part Number <sup>(1)</sup>	Firmware <sup>(2)</sup>	Description
RN41-I/RM	Latest Production	Class 1, 2.1+EDR, SPP profile
RN41-I/RM615	6.15	Class 1, 2.1+EDR, SPP profile
RN41-I/RM477	4.77	Class 1, 2.1+EDR, SPP profile
RN41HCI-I/RM	N/A	Class 1, 2.0+EDR, HCI over UART
RN41U-I/RM	N/A	Class 1, 2.0+EDR, HCI over USB
RN41HID-I/RM	6.11	Class 1, 2.1+EDR, HID and SPP profiles
RN41APL-I/RM	Latest Production	Class 1, 2.1+EDR, SPP and MFi profiles
RN41APL-I/RM545	5.45	Class 1, 2.1+EDR, SPP and MFi profiles
RN41APL-I/RM543	5.43	Class 1, 2.1+EDR, SPP and MFi profiles
RN41N-I/RM	Latest Production	Class 1, 2.1+EDR, SPP profile
RN41N-I/RM615	6.15	Class 1, 2.1+EDR, SPP profile
RN41N-I/RM477	4.77	Class 1, 2.1+EDR, SPP profile
RN41NAPL-I/RM	Latest Production	Class 1, 2.1+EDR, SPP and MFi profiles
RN41NAPL-I/RM545	5.45	Class 1, 2.1+EDR, SPP and MFi profiles
RN41NAPL-I/RM543	5.43	Class 1, 2.1+EDR, SPP and MFi profiles

**Note 1:** For other configurations, contact Microchip directly.

- 2:** When ordering the standard part number (customer part number without firmware version), the customer will receive the latest firmware version depending on production date and availability. It is highly recommended to order part number by specific firmware version to ensure receiving consistent firmware version. Information on firmware versions can be found on the RN41/RN41N product web page and the “*Bluetooth Data Module Command Reference and Advanced Information User’s Guide*”.

Go to <http://www.microchip.com> for current pricing and a list of distributors carrying Microchip products.

# RN41/RN41N

---

---

NOTES:

## APPENDIX A: REVISION HISTORY

### Revision C (June 2022)

This revision includes the following changes:

**TABLE C-1: MAJOR SECTION UPDATES**

Section	Update Description
<b>Section 3.6 “UKCA (UK Conformity Assessed)”</b>	Added UKCA regulatory approval information.

### Revision B (March 2021)

- Updated **Section 3.2.1 “Labeling and User Information Requirements”** and **Section 3.3 “Europe”**
- Updated with the new terminologies. For more details, see the below note.

**Note:** *Microchip is aware that some terminologies used in the technical documents and existing software codes of this product are outdated and unsuitable. This document may use these new terminologies, which may or may not reflect on the source codes, software GUIs, and the documents referenced within this document. The following table shows the relevant terminology changes made in this document.*

**TABLE 1: TERMINOLOGY RELATED CHANGES**

Old Terminology	New Terminology	Description
Master	Central	<ul style="list-style-type: none"> <li>• <b>Section “Features”</b> updated with the new terminology</li> <li>• <b>Section 1.1 “MCU Interface”</b> updated with the new terminology</li> <li>• <a href="#">Table 1-6</a> is updated with the new terminology</li> </ul>
Slave	Peripheral	<b>Section “Features”</b> updated with the new terminology
Slave	Client	<b>Section 2.6.2 “HCI over USB”</b> updated with the new terminology

### Revision A (August 2014)

This is the initial released version of the document in the Microchip format. This replaces Roving Networks RN41/RN41N Data Sheet.

# RN41/RN41N

---

---

NOTES:

## PRODUCT IDENTIFICATION SYSTEM

To order or obtain information, e.g., on pricing or delivery, refer to the factory or the listed sales office.

<u>PART NO.</u>	↓	<u>RM</u>	<u>XXX</u>	
Device	Temperature Range	Package	Firmware Revision Number	
<p><b>Device:</b></p> <p>RN41 : UART, Ceramic Chip Antenna            RN41N : UART, External Antenna            RN41HCI: HCI over UART, Ceramic Chip Antenna            RN41U : HCI over USB, Ceramic Chip Antenna            RN41APL: SPP and MFi profiles, Ceramic Chip Antenna</p> <p><b>Temperature Range:</b> I = -40°C to +85°C</p> <p><b>Package: *</b> RM = Radio Module</p> <p style="text-align: center;">*All package offerings are Pb Free (Lead Free)</p>				
				<p><b>Examples:</b></p> <p>a) RN41-I/RM: Ceramic Chip Antenna Latest production firmware version</p> <p>b) RN41-I/RM615: Ceramic Chip Antenna Firmware version 6.15</p> <p>c) RN41-I/RM477: Ceramic Chip Antenna Firmware version 4.77</p> <p>d) RN41APL-I/RM: Ceramic Chip Antenna Latest production firmware version</p> <p>e) RN41APL-I/RM543: Ceramic Chip Antenna firmware version 5.43</p> <p>f) RN41HCI-I/RM: Ceramic Chip Antenna HCI over UART</p>

# RN41/RN41N

---

---

NOTES:



## THE MICROCHIP WEB SITE

Microchip provides online support via our WWW site at [www.microchip.com](http://www.microchip.com). This web site is used as a means to make files and information easily available to customers. Accessible by using your favorite Internet browser, the web site contains the following information:

- **Product Support** – Data sheets and errata, application notes and sample programs, design resources, user's guides and hardware support documents, latest software releases and archived software
- **General Technical Support** – Frequently Asked Questions (FAQ), technical support requests, online discussion groups, Microchip consultant program member listing
- **Business of Microchip** – Product selector and ordering guides, latest Microchip press releases, listing of seminars and events, listings of Microchip sales offices, distributors and factory representatives

## CUSTOMER CHANGE NOTIFICATION SERVICE

Microchip's customer notification service helps keep customers current on Microchip products. Subscribers will receive e-mail notification whenever there are changes, updates, revisions or errata related to a specified product family or development tool of interest.

To register, access the Microchip web site at [www.microchip.com](http://www.microchip.com). Under "Support", click on "Customer Change Notification" and follow the registration instructions.

## CUSTOMER SUPPORT

Users of Microchip products can receive assistance through several channels:

- Distributor or Representative
- Local Sales Office
- Field Application Engineer (FAE)
- Technical Support

Customers should contact their distributor, representative or Field Application Engineer (FAE) for support. Local sales offices are also available to help customers. A listing of sales offices and locations is included in the back of this document.

**Technical support is available through the web site at: <http://microchip.com/support>**

# RN41/RN41N

---

---

NOTES:

---

---

**Note the following details of the code protection feature on Microchip products:**

- Microchip products meet the specifications contained in their particular Microchip Data Sheet.
- Microchip believes that its family of products is secure when used in the intended manner, within operating specifications, and under normal conditions.
- Microchip values and aggressively protects its intellectual property rights. Attempts to breach the code protection features of Microchip product is strictly prohibited and may violate the Digital Millennium Copyright Act.
- Neither Microchip nor any other semiconductor manufacturer can guarantee the security of its code. Code protection does not mean that we are guaranteeing the product is "unbreakable" Code protection is constantly evolving. Microchip is committed to continuously improving the code protection features of our products.

---

This publication and the information herein may be used only with Microchip products, including to design, test, and integrate Microchip products with your application. Use of this information in any other manner violates these terms. Information regarding device applications is provided only for your convenience and may be superseded by updates. It is your responsibility to ensure that your application meets with your specifications. Contact your local Microchip sales office for additional support or, obtain additional support at <https://www.microchip.com/en-us/support/design-help/client-support-services>.

THIS INFORMATION IS PROVIDED BY MICROCHIP "AS IS". MICROCHIP MAKES NO REPRESENTATIONS OR WARRANTIES OF ANY KIND WHETHER EXPRESS OR IMPLIED, WRITTEN OR ORAL, STATUTORY OR OTHERWISE, RELATED TO THE INFORMATION INCLUDING BUT NOT LIMITED TO ANY IMPLIED WARRANTIES OF NON-INFRINGEMENT, MERCHANTABILITY, AND FITNESS FOR A PARTICULAR PURPOSE, OR WARRANTIES RELATED TO ITS CONDITION, QUALITY, OR PERFORMANCE.

IN NO EVENT WILL MICROCHIP BE LIABLE FOR ANY INDIRECT, SPECIAL, PUNITIVE, INCIDENTAL, OR CONSEQUENTIAL LOSS, DAMAGE, COST, OR EXPENSE OF ANY KIND WHATSOEVER RELATED TO THE INFORMATION OR ITS USE, HOWEVER CAUSED, EVEN IF MICROCHIP HAS BEEN ADVISED OF THE POSSIBILITY OR THE DAMAGES ARE FORESEEABLE. TO THE FULLEST EXTENT ALLOWED BY LAW, MICROCHIP'S TOTAL LIABILITY ON ALL CLAIMS IN ANY WAY RELATED TO THE INFORMATION OR ITS USE WILL NOT EXCEED THE AMOUNT OF FEES, IF ANY, THAT YOU HAVE PAID DIRECTLY TO MICROCHIP FOR THE INFORMATION.

Use of Microchip devices in life support and/or safety applications is entirely at the buyer's risk, and the buyer agrees to defend, indemnify and hold harmless Microchip from any and all damages, claims, suits, or expenses resulting from such use. No licenses are conveyed, implicitly or otherwise, under any Microchip intellectual property rights unless otherwise stated.

For information regarding Microchip's Quality Management Systems, please visit [www.microchip.com/quality](http://www.microchip.com/quality).

**Trademarks**

The Microchip name and logo, the Microchip logo, Adaptec, AVR, AVR logo, AVR Freaks, BesTime, BitCloud, CryptoMemory, CryptoRF, dsPIC, flexPWR, HELDO, IGLoo, JukeBlox, KeeLoq, Klear, LANCheck, LinkMD, maXStylus, maXTouch, MediaLB, megaAVR, Microsemi, Microsemi logo, MOST, MOST logo, MPLAB, OptoLyzer, PIC, picoPower, PICSTART, PIC32 logo, PolarFire, Prochip Designer, QTouch, SAM-BA, SenGenuity, SpyNIC, SST, SST Logo, SuperFlash, Symmetricom, SyncServer, Tachyon, TimeSource, tinyAVR, UNI/O, Vectron, and XMEGA are registered trademarks of Microchip Technology Incorporated in the U.S.A. and other countries.

AgileSwitch, APT, ClockWorks, The Embedded Control Solutions Company, EtherSynch, Flashtec, Hyper Speed Control, HyperLight Load, Libero, motorBench, mTouch, Powermite 3, Precision Edge, ProASIC, ProASIC Plus, ProASIC Plus logo, Quiet-Wire, SmartFusion, SyncWorld, Temux, TimeCesium, TimeHub, TimePictra, TimeProvider, TrueTime, and ZL are registered trademarks of Microchip Technology Incorporated in the U.S.A.

Adjacent Key Suppression, AKS, Analog-for-the-Digital Age, Any Capacitor, AnyIn, AnyOut, Augmented Switching, BlueSky, BodyCom, Clockstudio, CodeGuard, CryptoAuthentication, CryptoAutomotive, CryptoCompanion, CryptoController, dsPICDEM, dsPICDEM.net, Dynamic Average Matching, DAM, ECAN, Espresso T1S, EtherGREEN, GridTime, IdealBridge, In-Circuit Serial Programming, ICSP, INICnet, Intelligent Paralleling, IntelliMOS, Inter-Chip Connectivity, JitterBlocker, Knob-on-Display, KoD, maxCrypto, maxView, memBrain, Mindi, MiWi, MPASM, MPF, MPLAB Certified logo, MPLIB, MPLINK, MultiTRAK, NetDetach, Omniscient Code Generation, PICDEM, PICDEM.net, PICkit, PICtail, PowerSmart, PureSilicon, QMatrix, REAL ICE, Ripple Blocker, RTAX, RTG4, SAM-ICE, Serial Quad I/O, simpleMAP, SimpliPHY, SmartBuffer, SmartHLS, SMART-I.S., storClad, SQI, SuperSwitcher, SuperSwitcher II, Switchtec, SynchroPHY, Total Endurance, Trusted Time, TSHARC, USBCheck, VariSense, VectorBlox, VeriPHY, ViewSpan, WiperLock, XpressConnect, and ZENA are trademarks of Microchip Technology Incorporated in the U.S.A. and other countries.

SQTP is a service mark of Microchip Technology Incorporated in the U.S.A.

The Adaptec logo, Frequency on Demand, Silicon Storage Technology, and Symmcom are registered trademarks of Microchip Technology Inc. in other countries.

GestIC is a registered trademark of Microchip Technology Germany II GmbH & Co. KG, a subsidiary of Microchip Technology Inc., in other countries.

All other trademarks mentioned herein are property of their respective companies.

© 2014-2022, Microchip Technology Incorporated and its subsidiaries.

All Rights Reserved.

ISBN: 978-1-6683-0554-6



# MICROCHIP

## Worldwide Sales and Service

### AMERICAS

**Corporate Office**  
2355 West Chandler Blvd.  
Chandler, AZ 85224-6199  
Tel: 480-792-7200  
Fax: 480-792-7277  
Technical Support:  
[http://www.microchip.com/  
support](http://www.microchip.com/support)  
Web Address:  
[www.microchip.com](http://www.microchip.com)

**Atlanta**  
Duluth, GA  
Tel: 678-957-9614  
Fax: 678-957-1455

**Austin, TX**  
Tel: 512-257-3370

**Boston**  
Westborough, MA  
Tel: 774-760-0087  
Fax: 774-760-0088

**Chicago**  
Itasca, IL  
Tel: 630-285-0071  
Fax: 630-285-0075

**Dallas**  
Addison, TX  
Tel: 972-818-7423  
Fax: 972-818-2924

**Detroit**  
Novi, MI  
Tel: 248-848-4000

**Houston, TX**  
Tel: 281-894-5983

**Indianapolis**  
Noblesville, IN  
Tel: 317-773-8323  
Fax: 317-773-5453  
Tel: 317-536-2380

**Los Angeles**  
Mission Viejo, CA  
Tel: 949-462-9523  
Fax: 949-462-9608  
Tel: 951-273-7800

**Raleigh, NC**  
Tel: 919-844-7510

**New York, NY**  
Tel: 631-435-6000

**San Jose, CA**  
Tel: 408-735-9110  
Tel: 408-436-4270

**Canada - Toronto**  
Tel: 905-695-1980  
Fax: 905-695-2078

### ASIA/PACIFIC

**Australia - Sydney**  
Tel: 61-2-9868-6733

**China - Beijing**  
Tel: 86-10-8569-7000

**China - Chengdu**  
Tel: 86-28-8665-5511

**China - Chongqing**  
Tel: 86-23-8980-9588

**China - Dongguan**  
Tel: 86-769-8702-9880

**China - Guangzhou**  
Tel: 86-20-8755-8029

**China - Hangzhou**  
Tel: 86-571-8792-8115

**China - Hong Kong SAR**  
Tel: 852-2943-5100

**China - Nanjing**  
Tel: 86-25-8473-2460

**China - Qingdao**  
Tel: 86-532-8502-7355

**China - Shanghai**  
Tel: 86-21-3326-8000

**China - Shenyang**  
Tel: 86-24-2334-2829

**China - Shenzhen**  
Tel: 86-755-8864-2200

**China - Suzhou**  
Tel: 86-186-6233-1526

**China - Wuhan**  
Tel: 86-27-5980-5300

**China - Xian**  
Tel: 86-29-8833-7252

**China - Xiamen**  
Tel: 86-592-2388138

**China - Zhuhai**  
Tel: 86-756-3210040

### ASIA/PACIFIC

**India - Bangalore**  
Tel: 91-80-3090-4444

**India - New Delhi**  
Tel: 91-11-4160-8631

**India - Pune**  
Tel: 91-20-4121-0141

**Japan - Osaka**  
Tel: 81-6-6152-7160

**Japan - Tokyo**  
Tel: 81-3-6880-3770

**Korea - Daegu**  
Tel: 82-53-744-4301

**Korea - Seoul**  
Tel: 82-2-554-7200

**Malaysia - Kuala Lumpur**  
Tel: 60-3-7651-7906

**Malaysia - Penang**  
Tel: 60-4-227-8870

**Philippines - Manila**  
Tel: 63-2-634-9065

**Singapore**  
Tel: 65-6334-8870

**Taiwan - Hsin Chu**  
Tel: 886-3-577-8366

**Taiwan - Kaohsiung**  
Tel: 886-7-213-7830

**Taiwan - Taipei**  
Tel: 886-2-2508-8600

**Thailand - Bangkok**  
Tel: 66-2-694-1351

**Vietnam - Ho Chi Minh**  
Tel: 84-28-5448-2100

### EUROPE

**Austria - Wels**  
Tel: 43-7242-2244-39  
Fax: 43-7242-2244-393

**Denmark - Copenhagen**  
Tel: 45-4485-5910  
Fax: 45-4485-2829

**Finland - Espoo**  
Tel: 358-9-4520-820

**France - Paris**  
Tel: 33-1-69-53-63-20  
Fax: 33-1-69-30-90-79

**Germany - Garching**  
Tel: 49-8931-9700

**Germany - Haan**  
Tel: 49-2129-3766400

**Germany - Heilbronn**  
Tel: 49-7131-72400

**Germany - Karlsruhe**  
Tel: 49-721-625370

**Germany - Munich**  
Tel: 49-89-627-144-0  
Fax: 49-89-627-144-44

**Germany - Rosenheim**  
Tel: 49-8031-354-560

**Israel - Ra'anana**  
Tel: 972-9-744-7705

**Italy - Milan**  
Tel: 39-0331-742611  
Fax: 39-0331-466781

**Italy - Padova**  
Tel: 39-049-7625286

**Netherlands - Drunen**  
Tel: 31-416-690399  
Fax: 31-416-690340

**Norway - Trondheim**  
Tel: 47-7288-4388

**Poland - Warsaw**  
Tel: 48-22-3325737

**Romania - Bucharest**  
Tel: 40-21-407-87-50

**Spain - Madrid**  
Tel: 34-91-708-08-90  
Fax: 34-91-708-08-91

**Sweden - Gothenberg**  
Tel: 46-31-704-60-40

**Sweden - Stockholm**  
Tel: 46-8-5090-4654

**UK - Wokingham**  
Tel: 44-118-921-5800  
Fax: 44-118-921-5820