



# U10

## Quectel Cellular Engine

### **EVB User Guide**

U10\_EVB\_User\_Guide\_V1.0

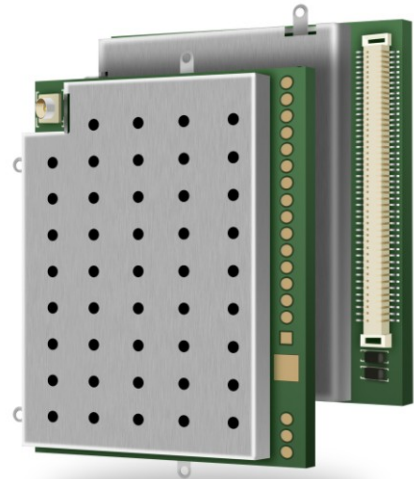

<b>Document Title</b>	U10 EVB User Guide
<b>Version</b>	1.0
<b>Date</b>	2012-03-01
<b>Status</b>	Released
<b>Document Control ID</b>	U10_EVB_User_Gudie_V1.0

### **General Notes**

Quectel offers this information as a service to its customers, to support application and engineering efforts that use the products designed by Quectel. The information provided is based upon requirements specifically provided for Quectel by the customers. Quectel has not undertaken any independent search for additional relevant information, including any information that may be in the customer's possession. Furthermore, system validation of this product designed by Quectel within a larger electronic system remains the responsibility of the customer or the customer's system integrator. All specifications supplied herein are subject to change.

### **Copyright**

This document contains proprietary technical information which is the property of Quectel Limited. The copying of this document, distribution to others, and communication of the contents thereof, are forbidden without express authority. Offenders are liable to the payment of damages. All rights are reserved in the event of a patent grant or registration of a utility model or design. All specification supplied herein are subject to change without notice at any time.

***Copyright © Quectel Wireless Solutions Co., Ltd. 2012***

## Contents

Contents .....	2
Table Index.....	4
Figure Index .....	5
0. Revision history .....	7
1. Introduction.....	8
1.1. Related documents .....	8
1.2. Safety precautions .....	8
2. EVB kit .....	10
2.1. EVB view .....	11
2.2. EVB accessory .....	12
3. Interface application.....	14
3.1. Power interface.....	14
3.2. Charging interface.....	16
3.3. Audio interface.....	17
3.3.1. Handset.....	17
3.3.2. Earphone.....	19
3.3.3. Loud speaker .....	21
3.3.4. PCM interface.....	22
3.4. SIM Card interface.....	23
3.4.1. SIM1 card interface.....	23
3.4.2. SIM2 card interface.....	25
3.5. Antenna interface .....	26
3.6. UART port .....	26
3.6.1. Main UART.....	28
3.6.2. Debug UART and Auxiliary UART.....	29
3.7. Camera interface .....	30
3.7.1. Analog camera.....	30
3.7.2. Digital camera .....	32
3.8. SD card interface.....	34
3.9. USB interface .....	35
3.10. Switches and buttons.....	37
3.10.1. Switch for VBAT power supply.....	37
3.10.2. Switch for VCHG function.....	38
3.10.3. Switch for UART download.....	39
3.10.4. Button for PWRKEY.....	39
3.10.5. Button for EMERG_OFF .....	39
3.11. Operating Status LED .....	40
3.12. ADC .....	40
3.13. Test points .....	41
3.13.1. CON1.....	42
3.13.2. CON2.....	42

3.13.3. CON3.....	43
4. EVB accessories assembly.....	44
5. Illustration.....	45
5.1. Power on.....	45
5.2. Power off the module.....	45
5.3. Emergency off.....	45
5.4. Communicate with the module through UART port.....	46
5.5. Communicate with the module through USB interface.....	46
5.6 Firmware upgrade.....	46
5.6.1. Upgrade firmware through UART interface.....	47
5.6.2. Upgrade firmware through USB interface.....	47

## Table Index

TABLE 1: RELATED DOCUMENTS .....	8
TABLE 2: KEY FEATURES.....	10
TABLE 3: DESCRIPTION OF EVB COMPONENTS.....	12
TABLE 4: ITEMS OF EVB KIT.....	13
TABLE 5: PIN OF POWER INTERFACE .....	15
TABLE 6: PIN OF BATTERY INTERFACE.....	17
TABLE 7: PINS DEFINITION OF CHANNEL 1 .....	18
TABLE 8: PINS DEFINITION OF CHANNEL 2 .....	19
TABLE 9: PINS ASSIGNMENT OF AUDIO JACK.....	21
TABLE 10: PINS OF LOUD SPEAKER.....	22
TABLE 11: PINS OF PCM AUDIO.....	23
TABLE 12: PIN DESCRIPTION OF SIM1 CARD CASSETTE .....	24
TABLE 13: PIN DESCRIPTION OF SIM2 CARD HOLDER.....	26
TABLE 14: PINS OF MAIN UART PORT.....	28
TABLE 15: PINS OF AUXILIARY UART PORT.....	29
TABLE 16: PINS OF DEBUG UART PORT.....	30
TABLE 17: PIN DEFINITION OF THE CAMERA INTERFACE .....	33
TABLE 18: PIN DEFINITION OF THE SD CARD INTERFACE.....	35
TABLE 19: PIN DEFINITION OF USB INTERFACE.....	36
TABLE 20: SWITCHES AND BUTTONS.....	37
TABLE 21: STATUS LEDS .....	40
TABLE 22: PINS OF CON1 .....	42
TABLE 23: PINS OF CON2 .....	43
TABLE 24: PINS OF CON3 .....	43
TABLE 25: WORKING STATE OF THE NETLIGHT1 .....	45

## Figure Index

FIGURE 1: EVB FUNCTIONAL DIAGRAM .....	10
FIGURE 2: EVB TOP VIEW .....	11
FIGURE 3: EVB BOTTOM VIEW .....	11
FIGURE 4: EVB KIT INTRODUCTION .....	13
FIGURE 5: REFERENCE CIRCUIT OF THE POWER SUPPLY .....	14
FIGURE 6: POWER INTERFACE .....	15
FIGURE 7: POWER PLUG .....	15
FIGURE 8: TEST POINT OF VBAT .....	16
FIGURE 9: REFERENCE CIRCUIT OF CHARGING INTERFACE .....	16
FIGURE 10: CHARGING INTERFACE .....	17
FIGURE 11: REFERENCE DESIGN FOR HANDSET OF CHANNEL 1 .....	17
FIGURE 12: REFERENCE DESIGN FOR HANDSET OF CHANNEL 2 .....	18
FIGURE 13: AUDIO INTERFACE .....	18
FIGURE 14: CONNECTION BETWEEN HANDSET AND RJ11 .....	19
FIGURE 15: REFERENCE DESIGN FOR EARPHONE OF CHANNEL 2 .....	20
FIGURE 16: AUDIO JACK TOP VIEW .....	20
FIGURE 17: THE SKETCH OF AUDIO PLUG .....	21
FIGURE 18: LOUD SPEAKER CIRCUIT WITH EXTERNAL AMPLIFIER .....	21
FIGURE 19: LOUD SPEAKER INTERFACE .....	22
FIGURE 20: BLOCK DIAGRAM OF PCM .....	22
FIGURE 21: PCM AUDIO INTERFACE .....	23
FIGURE 22: CIRCUIT OF SIM1 CARD .....	24
FIGURE 23: PINS ASSIGNMENT OF SIM1 CARD .....	24
FIGURE 24: CIRCUIT OF SIM2 CARD .....	25
FIGURE 25: SIM2 CARD HOLDER .....	25
FIGURE 26: ANTENNA INSTALLING .....	26
FIGURE 27: UART BLOCK DIAGRAM .....	27
FIGURE 28: LEVEL MATCH CIRCUIT .....	27
FIGURE 29: MAIN UART PORT .....	28
FIGURE 30: TEST POINTS OF MAIN UART PORT .....	29
FIGURE 31: AUXILIARY UART AND DEBUG UART .....	29
FIGURE 32: TEST POINTS OF AUXILIARY AND DEBUG PORT .....	30
FIGURE 33: BLOCK DIAGRAM OF ANALOG CAMERA .....	31
FIGURE 34: TEST POINT OF ANALOG CAMERA .....	31
FIGURE 35: ANALOG CAMERA .....	32
FIGURE 36: REFERENCE CIRCUIT OF USING DIGITAL CMOS SENSOR .....	32
FIGURE 37: INSTALLATION OF THE CAMERA MODULE .....	33
FIGURE 38: MICRO SD CARD CIRCUIT .....	34
FIGURE 39: MICRO SD CARD INTERFACE .....	34
FIGURE 40: CIRCUIT OF USB INTERFACE .....	35
FIGURE 41: MINI USB CONNECTOR .....	36

FIGURE 42: USB CABLE.....	36
FIGURE 43: SWITCHES AND BUTTONS .....	37
FIGURE 44: SWITCH FOR VBAT POWER SUPPLY .....	38
FIGURE 45: SWITCH FOR CHARGING FUNCTION.....	38
FIGURE 46: SWITCH FOR UART DOWNLOAD.....	39
FIGURE 47: OPERATING STATUS LED .....	40
FIGURE 48: CIRCUIT OF ADC .....	41
FIGURE 49: TEST POINT OF ADC .....	41
FIGURE 50: TEST POINTS OVERVIEW .....	41
FIGURE 51: CON1 .....	42
FIGURE 52: CON2 .....	42
FIGURE 53: CON3 .....	43
FIGURE 54: EVB AND ACCESSORIES EQUIPMENT.....	44

## 0. Revision history

Revision	Date	Author	Description of change
1.0	2012-02-28	Bruce Yu	Initial



## 1. Introduction

This document defines and specifies the usage of U10 EVB. Customers can get useful information about U10 EVB from this document.

### 1.1. Related documents

**Table 1: Related documents**

SN	Document name	Remark
[1]	U10_ATC	AT commands sets
[2]	GSM_UART_AN	The document of serial port application notes
[3]	U10_HD	Hardware design

### 1.2. Safety precautions

The following safety precautions must be observed during all phases of the operation, such as usage, service or repair of any cellular terminal or mobile incorporating U10 module. Manufacturers of the cellular terminal are advised to convey the following safety information to users and operating personnel and to incorporate these guidelines into all manuals supplied with the product. If not so, Quectel does not take on any liability for customer failure to comply with these precautions.



When in a hospital or other health care facility, observe the restrictions on the use of mobile. Switch the cellular terminal or mobile off. Medical equipment may be sensitive to RF energy interference.



Switch off the cellular terminal or mobile before boarding an aircraft. Make sure it switched off. The operation of wireless appliances in an aircraft is forbidden to prevent interference with communication systems. Forget to think much of these instructions may influence the flight safety or offend against local legal action, or both.



Do not operate the cellular terminal or mobile in the presence of flammable gas or fume. Switch off the cellular terminal when you are near petrol station, fuel depot, chemical plant or where blasting operations are in progress. Operation of any electrical equipment in potentially explosive atmosphere can constitute a safety hazard.



Your cellular terminal or mobile receives and transmits radio frequency energy while switched on. RF interference can occur if it is used close to TV set, radio, computer or other electric equipment.



Road safety comes first! Do not use a hand-held cellular terminal or mobile while driving a vehicle, unless it is securely mounted in a holder for hands-free operation. Before making a call with a hand-held terminal or mobile, park the vehicle.



GSM cellular terminals or mobiles operate using radio frequency signal and cellular network. Because of this, the connection cannot be guaranteed in all conditions, for example no mobile fee or an invalid SIM card. While you are in this condition and need emergent help, please remember using emergency call. In order to make or receive calls, the cellular terminal or mobile must be switched on and in a service area with adequate cellular signal strength.

Some networks do not allow for emergency call if certain network services or phone features are in use (e.g. lock functions, fixed dialing etc.). You may have to deactivate those features before you can make an emergency call.

Also, some networks require that a valid SIM card be properly inserted in cellular terminal or mobile.

## 2. EVB kit

Quectel supplies U10-EVB kit for designer to develop applications based on the 3G module U10. All the functions of the U10 can be used by this board. The following table shows the key features of the EVB.

**Table 2: Key features**

Feature	Implementation
Power supply	<ul style="list-style-type: none"> <li>● DC supply 4.4~7.0V typically 5V</li> <li>● VBAT: 3.4V~4.6V at J102</li> </ul>
Functions	<ul style="list-style-type: none"> <li>● UART interface</li> <li>● USB2.0 interface</li> <li>● SIM card interface</li> <li>● MICRO SD card interface</li> <li>● Audio interface</li> <li>● ADC interface</li> <li>● Camera interface</li> <li>● Charging interface</li> <li>● Power on/off control</li> <li>● Status/Network indication</li> </ul>

The functional diagram of U10-EVB is shown in Figure 1.

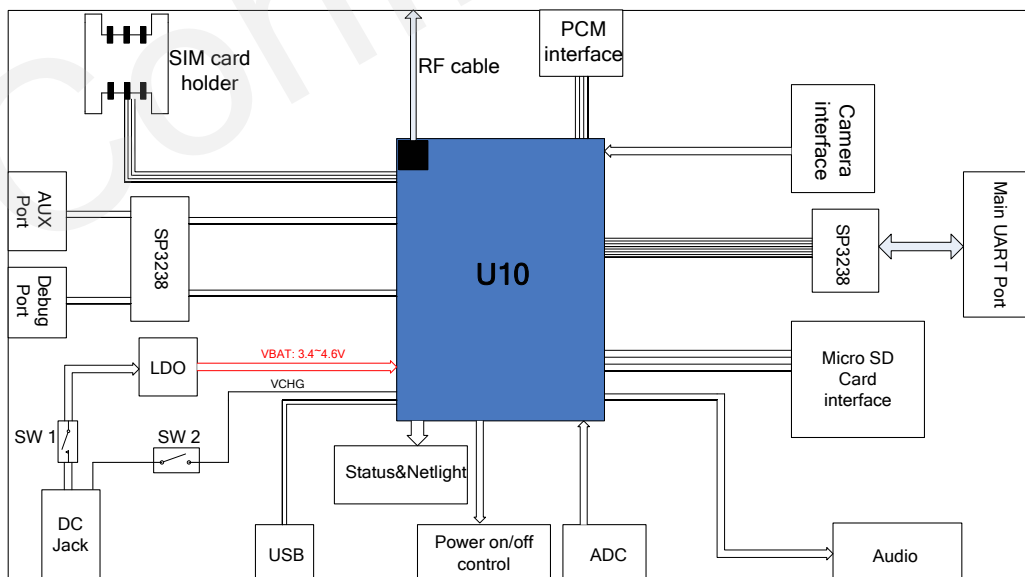

**Figure 1: EVB functional diagram**

## 2.1. EVB view

The following figures show the top view and bottom view of the EVB.

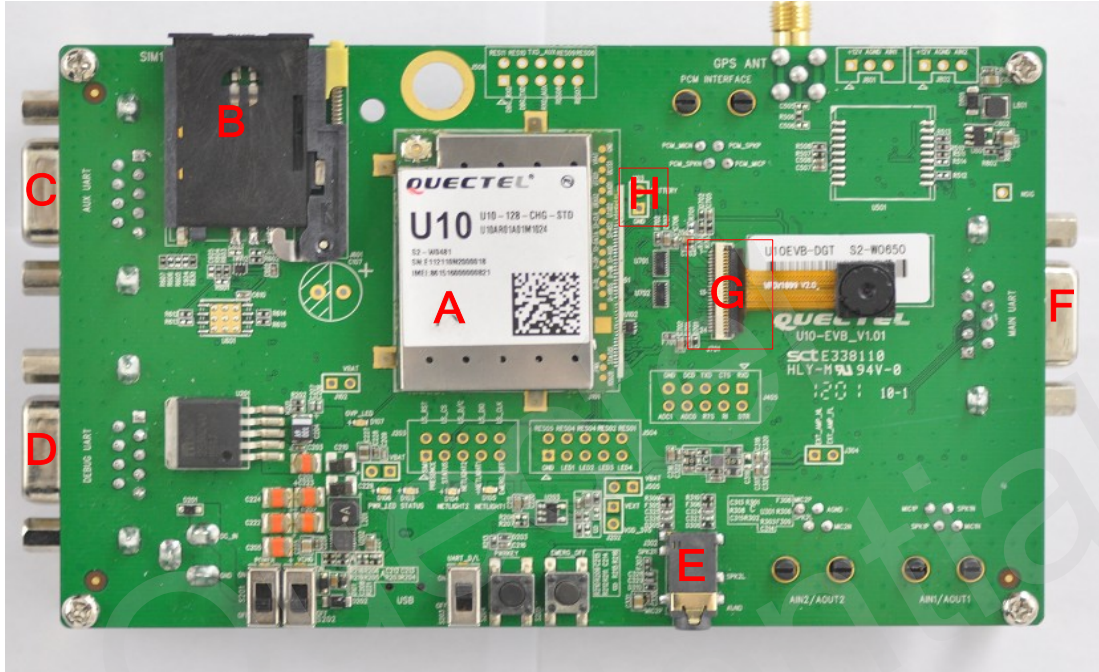

Figure 2: EVB top view

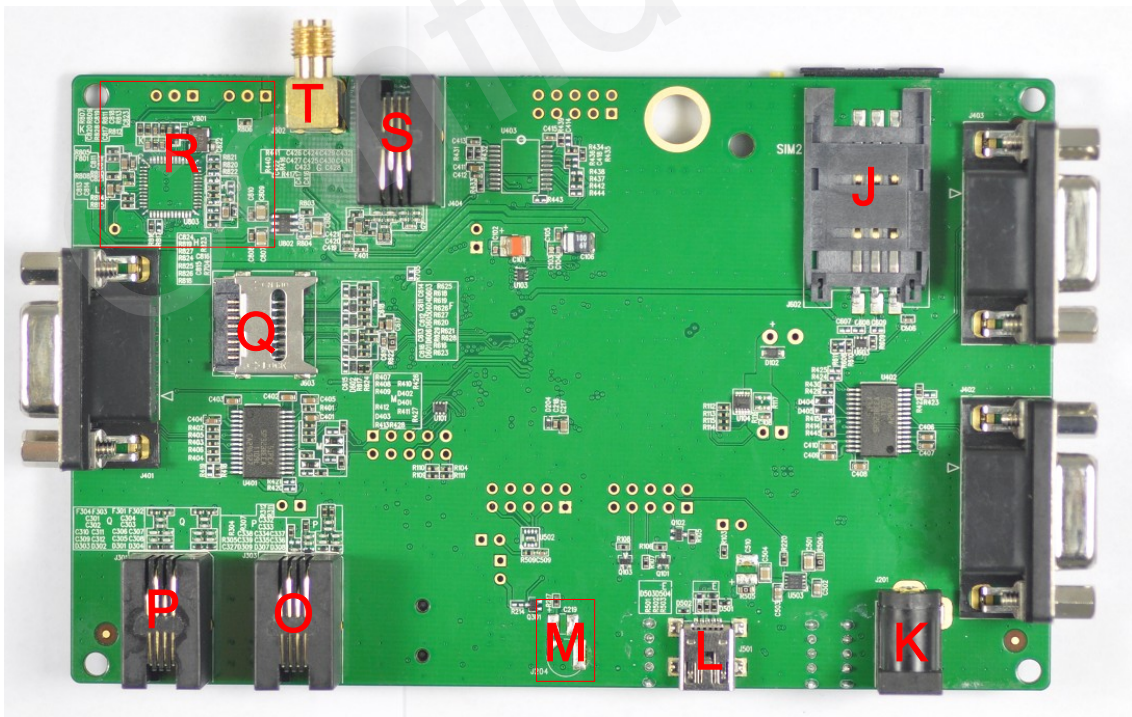

Figure 3: EVB bottom view

**Table 3: Description of EVB components**

Part NO.	Description
A	U10 Module
B	SIM1 card cassette
C	Auxiliary UART Port
D	Debug UART Port
E	Earphone interface of audio channel 2
F	Main UART Port
G	Camera interface
H	Charge interface
J	SIM2 card holder
K	5V DC Jack
L	Mini-USB connector
M	RTC interface
O	Handset interface of audio channel 2
P	Handset interface of audio channel 1
Q	SD card cassette
R	Analogy camera interface
S	PCM audio
T	GPS RF connector

## 2.2. EVB accessory

All the items of EVB Kit are listed in Figure 4 and Table 4 below. Please contact the supplier if there is something missing.

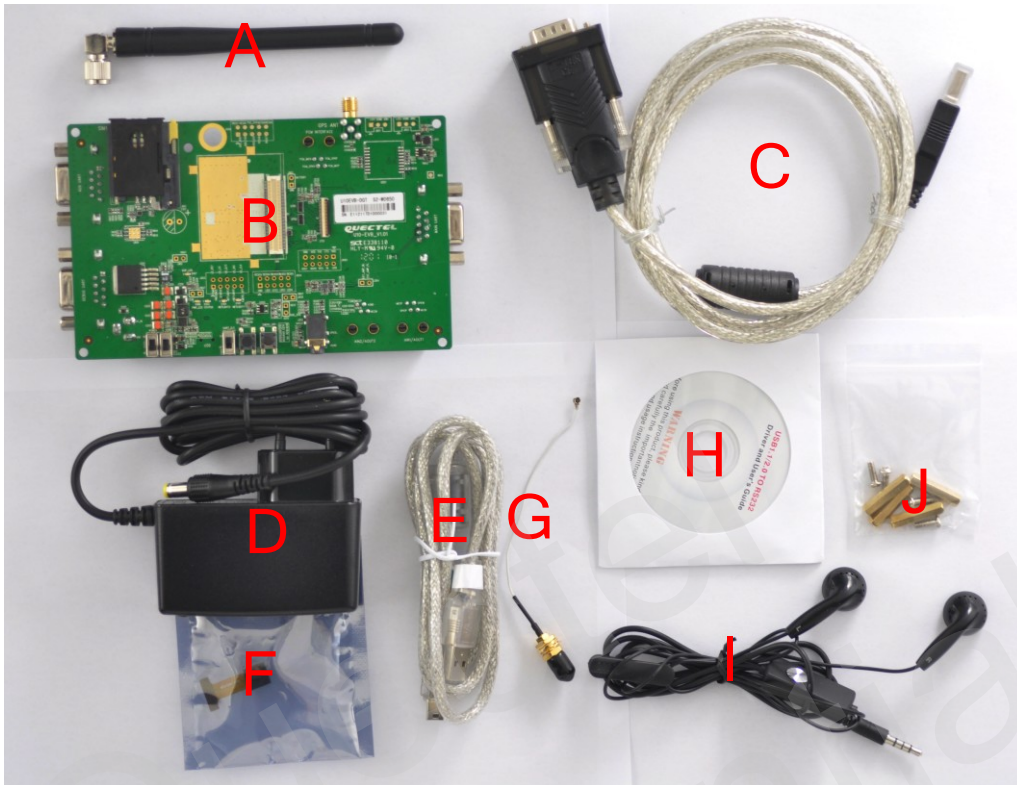

Figure 4: EVB kit introduction

Table 4: Items of EVB kit

Part NO.	Description	Quantity
A	Antenna	1
B	U10-EVB	1
C	USB to UART converter cable	1
D	5V DC switching adapter	1
E	USB cable	1
F	2M pixels camera module	1
G	RF cable	1
H	Driver disk	1
I	Earphone	1
J	Bolts and nuts for fixing module and EVB	1

### 3. Interface application

This chapter describes the hardware interfaces of U10-EVB as follow:

- 1) Power interface
- 2) Charging interface
- 3) Audio interface
- 4) PCM interface
- 5) SIM card interface
- 6) Antenna interface
- 7) UART interface
- 8) Camera interface
- 9) SD card interface
- 10) USB interface
- 11) ADC interface

It also provides the LED and Button information and test points of the module to help customers understand how to use the U10 EVB.

#### 3.1. Power interface

The power supply of U10-EVB could be from external input which connected to power jack on the EVB board. The power jack connects to a LDO which can provide the correct voltage to the U10 module. The reference design of the LDO circuit is shown in Figure 5.

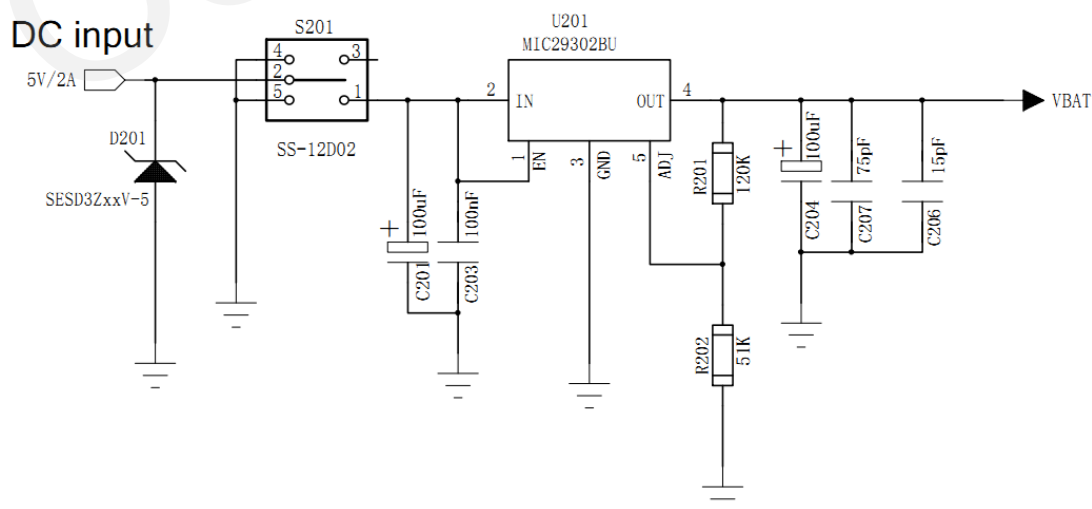

Figure 5: Reference circuit of the power supply

The Figure 6 shows the power interface of U10-EVB.

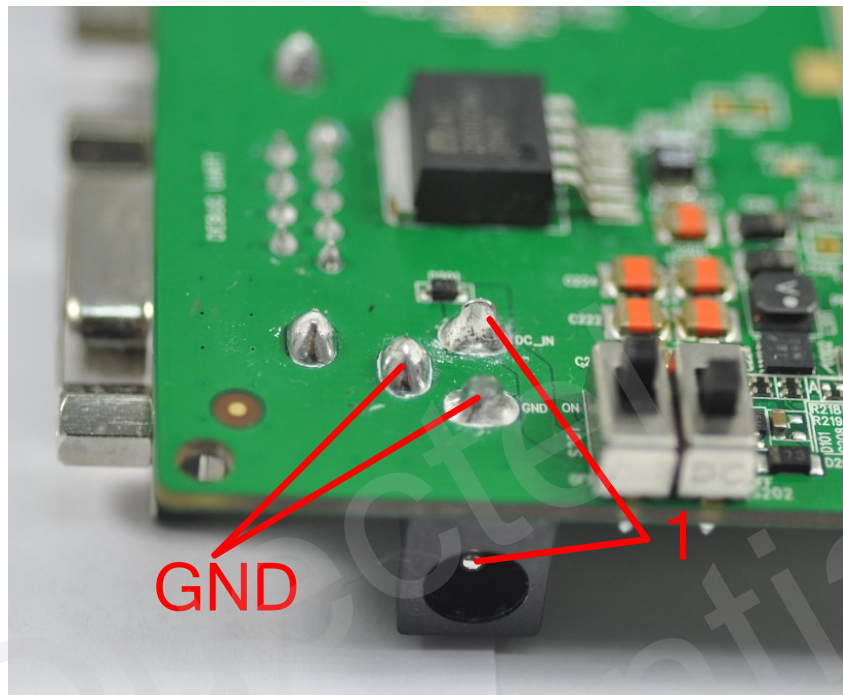

Figure 6: Power interface

Table 5: Pin of power interface

Pin NO.	Signal	I/O	Description
1	Adapter input	I	5V/2A DC source input

Customers need to use the right DC adapter which provided by Quectel shown in Figure 7.

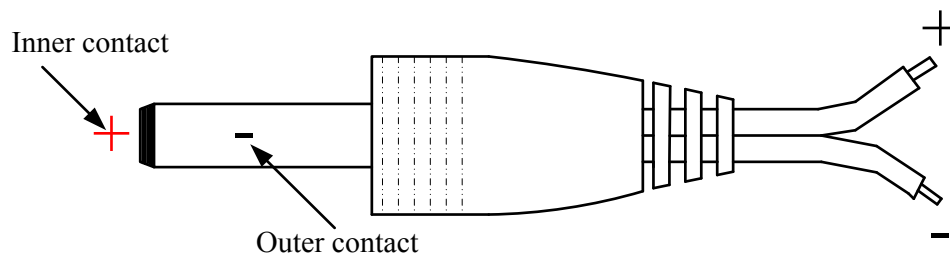
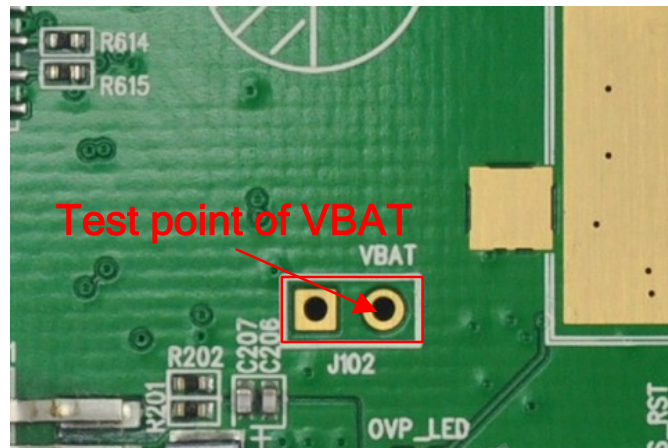

Figure 7: Power plug

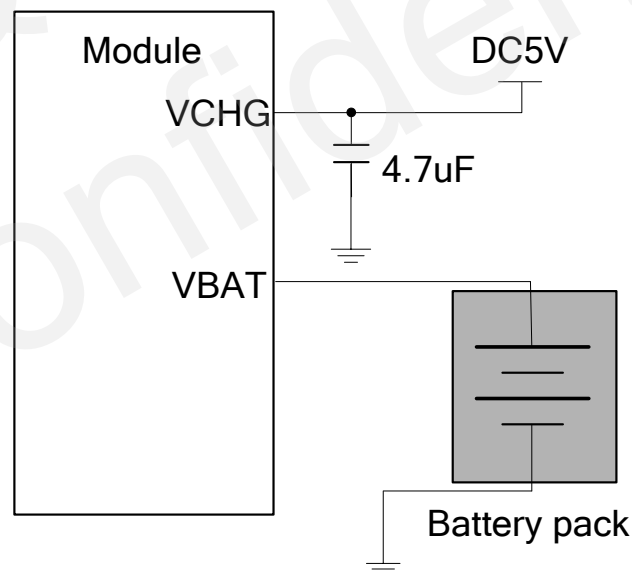



**Figure 8: Test point of VBAT**

### 3.2. Charging interface

U10 has embedded the whole charging function for rechargeable Li-Ion or Lithium Polymer battery so that customers can quickly design the circuit with less cost. The U10-EVB reserved charging pins for customers to connect the rechargeable battery. The following figure shows the reference circuit of the charging interface.



**Figure 9: Reference circuit of charging interface**

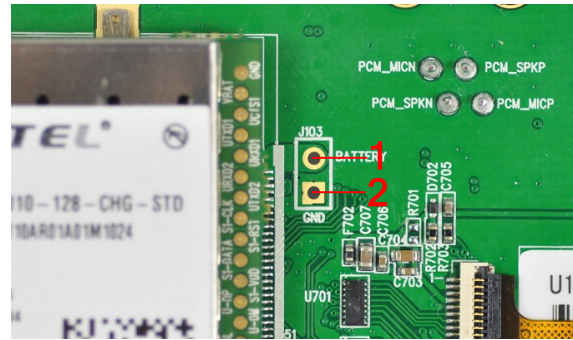

Figure 10: Charging interface

Table 6: Pin of battery interface

Pin NO.	Signal	I/O	Description
1	Battery	I/O	Battery contact pin
2	GND	/	GND

### 3.3. Audio interface

U10 module provides two audio channels. In this chapter, we will introduce these audio in details.

#### 3.3.1. Handset

AIN1/AOUT1, AIN2/AOUT2 are designed in handset. The block diagram of AIN1/AOUT1, AIN2/AOUT2 is shown as below and some details are concealed. If you want to get more information, please refer to *document [3]*

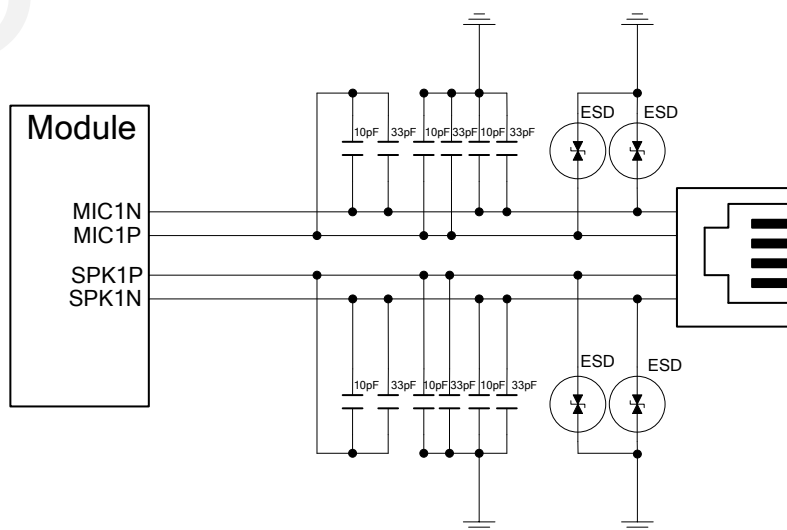

Figure 11: Reference design for handset of channel 1

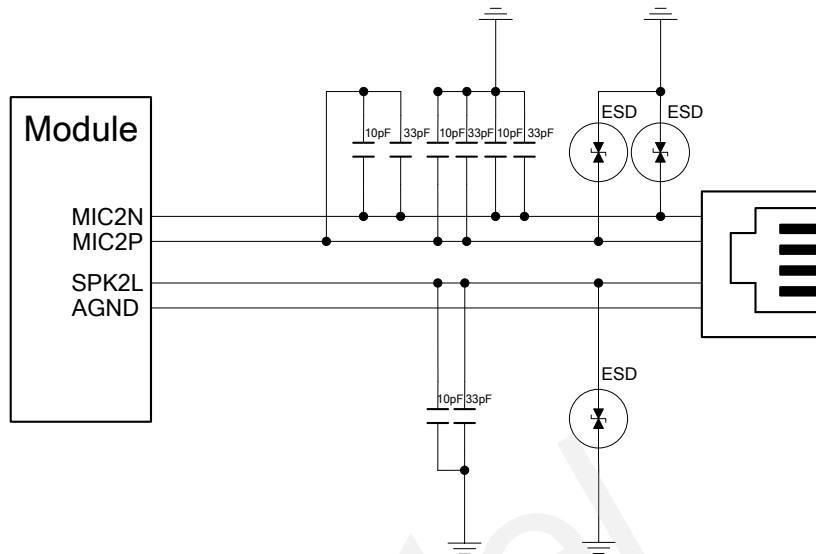

Figure 12: Reference design for handset of channel 2

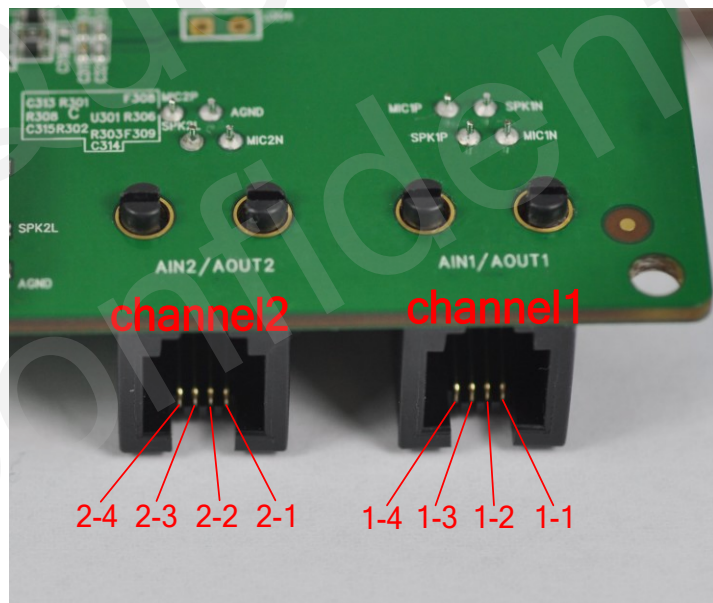

Figure 13: Audio interface

Table 7: Pins definition of channel 1

Pin NO.	Signal	I/O	Description
1-1	MIC1N	I	Negative input of audio channel 1
1-2	SPK1N	O	Negative output of audio channel 1
1-3	SPK1P	O	Positive output of audio channel 1
1-4	MIC1P	I	Positive input of audio channel 1

**Table 8: Pins definition of channel 2**

Pin NO.	Signal	I/O	Description
2-1	MIC2N	I	Negative input of audio channel 2
2-2	AGND	/	Dedicated GND for Audio
2-3	SPK2L	O	Left channel of stereo audio output
2-4	MIC2P	I	Positive input of audio channel 2

The handset which suits for the U10 EVB is different from the common handset and Quectel do not provide this handset. The following picture illustrates a connection between RJ11 and handset. Customer can refer to the following picture to make a handset which suits for the U10 EVB.

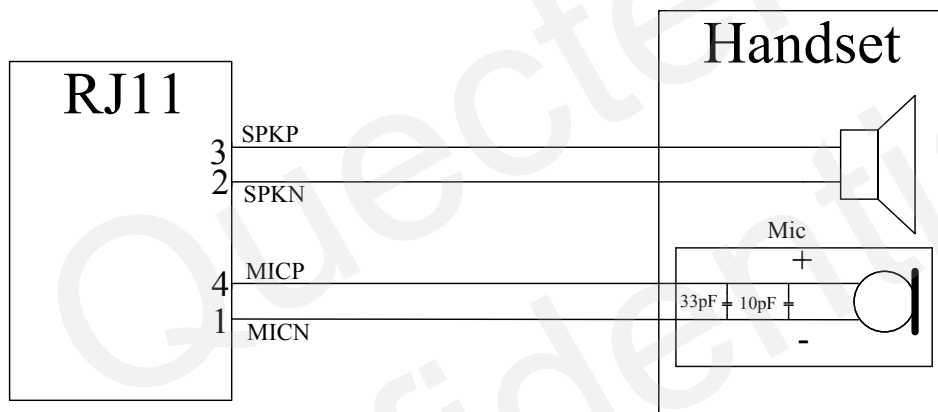
**Figure 14: Connection between handset and RJ11**

### 3.3.2. Earphone

An earphone also can be used in audio channel 2. The reference design of audio channel for earphone is shown as below:

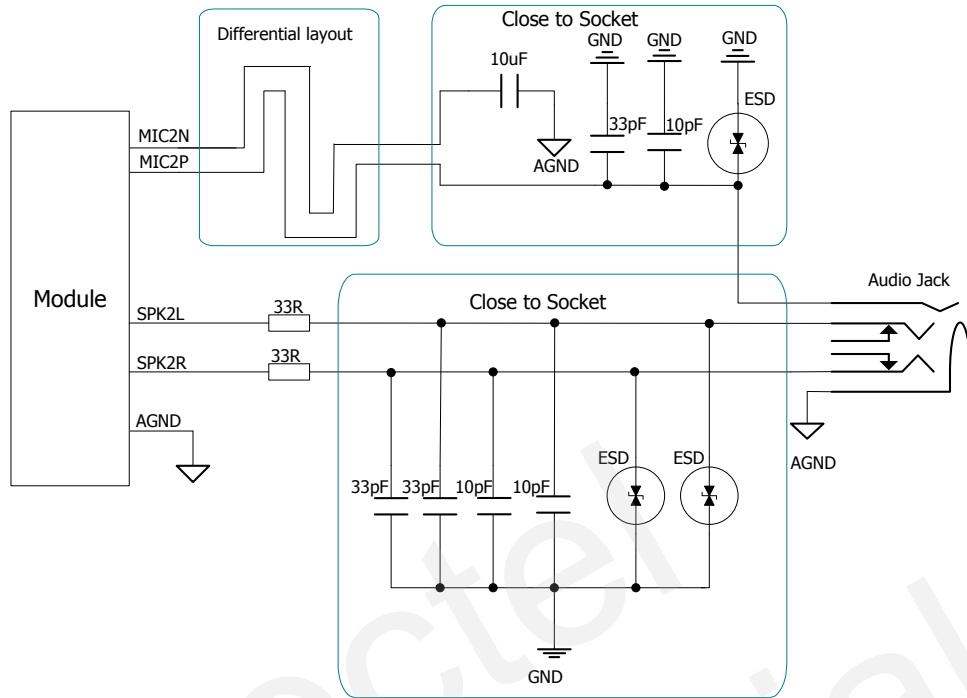

Figure 15: Reference design for earphone of channel 2

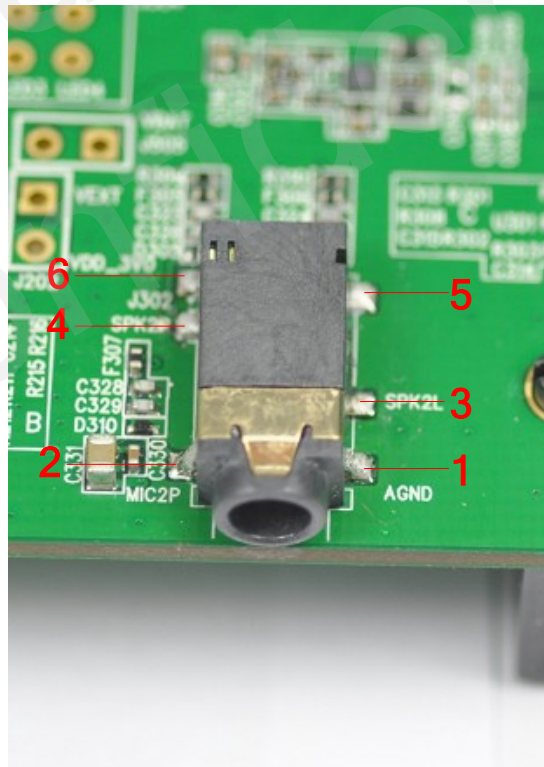
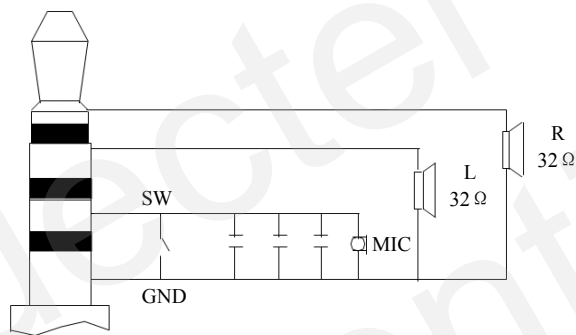

Figure 16: Audio jack top view

**Table 9: Pins assignment of audio jack**

Pin NO.	Signal	I/O	Description
1	AGND	/	Dedicated GND for Audio
2	MIC2P	I	Negative input of audio channel 2
3	SPK2L	O	Left channel of stereo audio output
4	SPK2R	O	Right channel of stereo audio output
5	NC	/	
6	NC	/	

The following figure shows the sketch of audio plug which suits for the audio jack on U10-EVB.

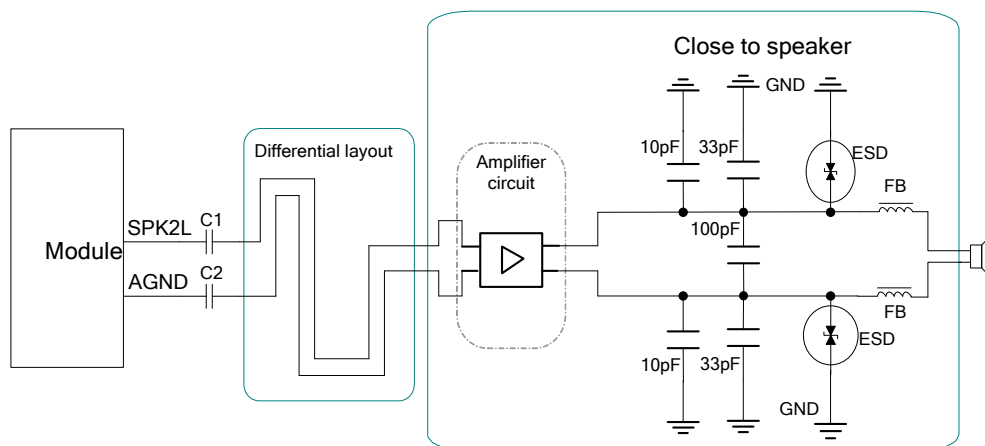

**Figure 17: The sketch of Audio plug**

*Note: For different earphone, the right channel and left channel may be different. Please change the circuit for different earphone.*

### 3.3.3. Loud speaker

Figure 18 shows the loud speaker circuit with external audio Class-D amplifier.



**Figure 18: Loud Speaker circuit with external amplifier**

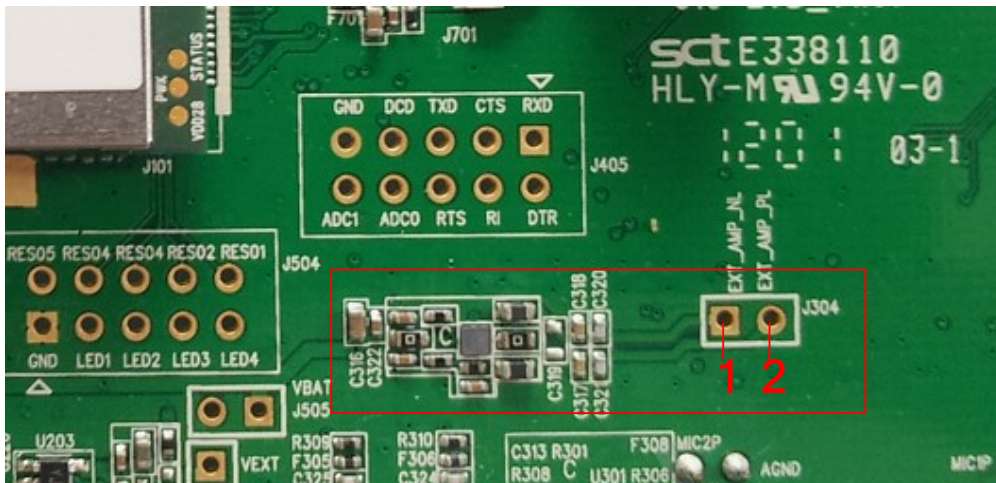

Figure 19: Loud speaker interface

Table 10: Pins of loud speaker

Pin NO.	Signal	I/O	Description
1	EXT_AMP_NL	O	Negative loud speaker output
2	EXT_AMP_PL	O	Positive loud speaker output

### 3.3.4. PCM interface

The module also provides a PCM interface. An audio codec, W681360 is recommended. The audio codec converts the analog signal to digital signal with each other. The following figure shows the block diagram of the PCM audio interface.

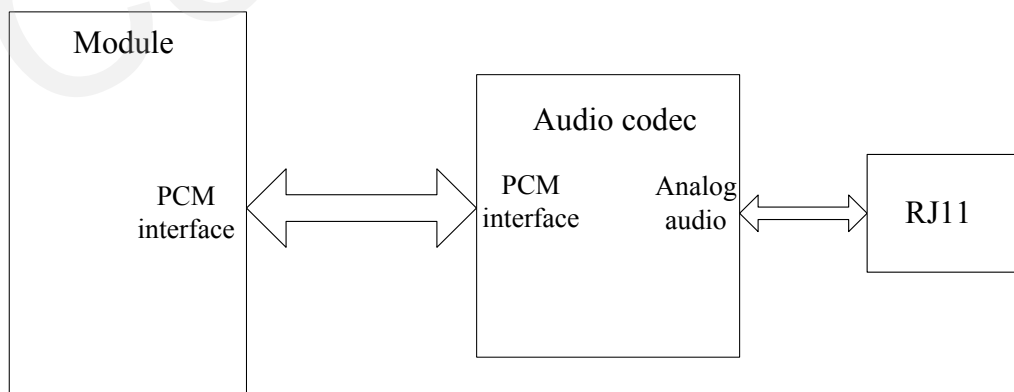
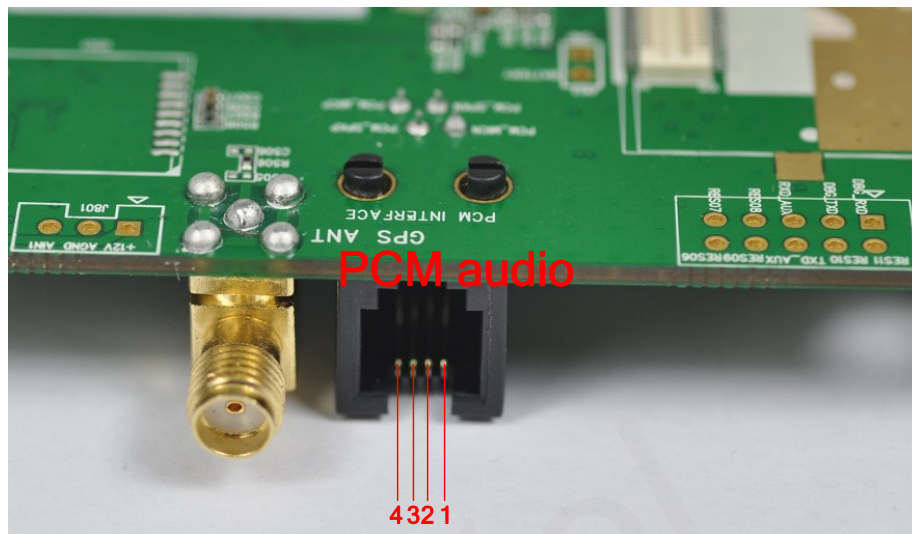

Figure 20: Block diagram of PCM



**Figure 21: PCM audio interface**

**Table 11: Pins of PCM audio**

Pin NO.	Signal	I/O	Description	Note
1	PCM_MICN	I	Negative input to audio codec	Not supported currently
2	PCM_SPKN	O	Negative output from audio codec	
3	PCM_SPKP	O	Positive output from audio codec	
4	PCM_MICP	I	Positive input to audio codec	

**NOTE:** The W681360 is not assembled in the EVB board. If you want to use this function, please assemble this component located at U403

### 3.4. SIM Card interface

U10 has two SIM interfaces that support two SIM cards simultaneously. SIM1 interface can support both USIM and SIM card while SIM2 interface can support SIM card only. Both interfaces support 1.8V or 3.0V SIM cards automatically.

#### 3.4.1. SIM1 card interface

Figure 22 and 23 shows the schematic of SIM1 card and the pins assignment of SIM1 card respectively.



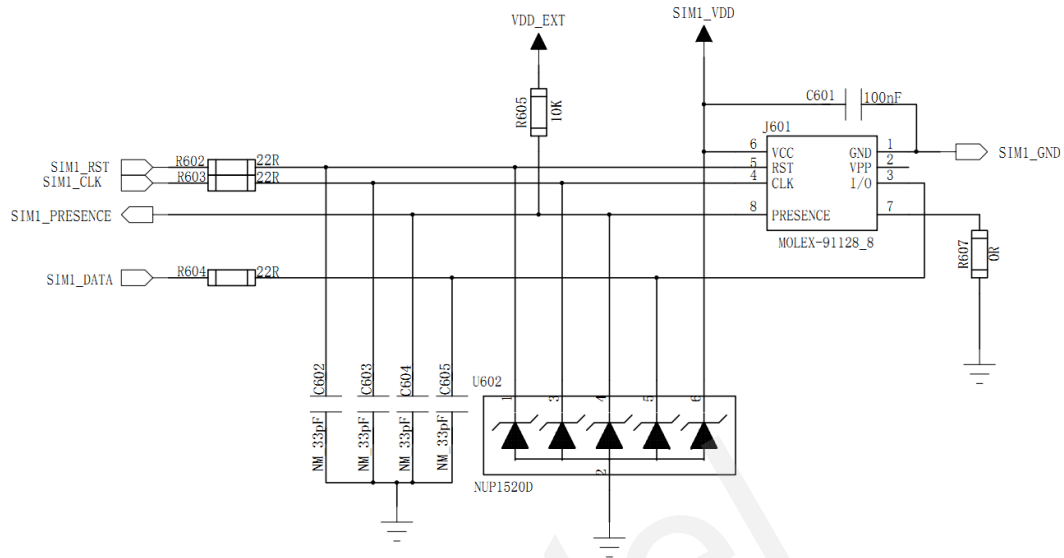

Figure 22: Circuit of SIM1 card

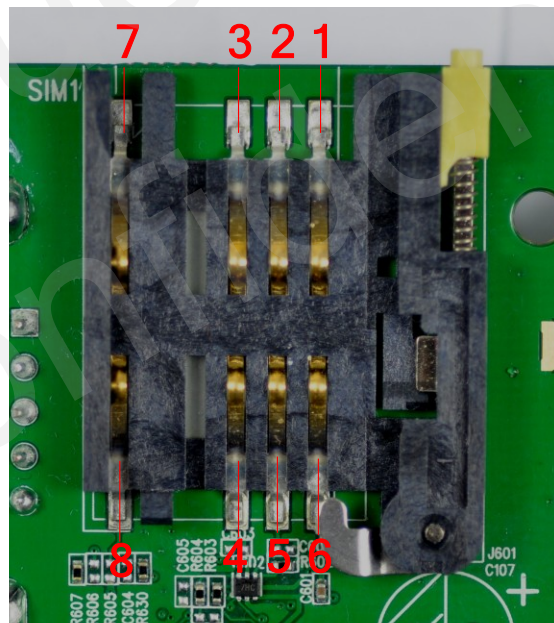

Figure 23: Pins assignment of SIM1 card

Table 12: Pin description of SIM1 card cassette

Pin NO.	Signal	I/O	Description	Note
1	GND	/	GND	
2	VPP	/	Not connected	
3	SIM1_DATA	I/O	SIM1 card data I/O	
4	SIM1_CLK	O	SIM1 card clock	

5	SIM1_RST	O	SIM1 card reset	
6	SIM1_VDD	O	SIM1 power	
7		/	Pulled down to GND with external circuit. When the SIM card is inserted, pin 7 is connected to pin 8.	
8	SIM1_PRESENCE	I	SIM1 Card detection	

### 3.4.2. SIM2 card interface

The schematic of SIM2 card and the SIM card holder is shown as follow.

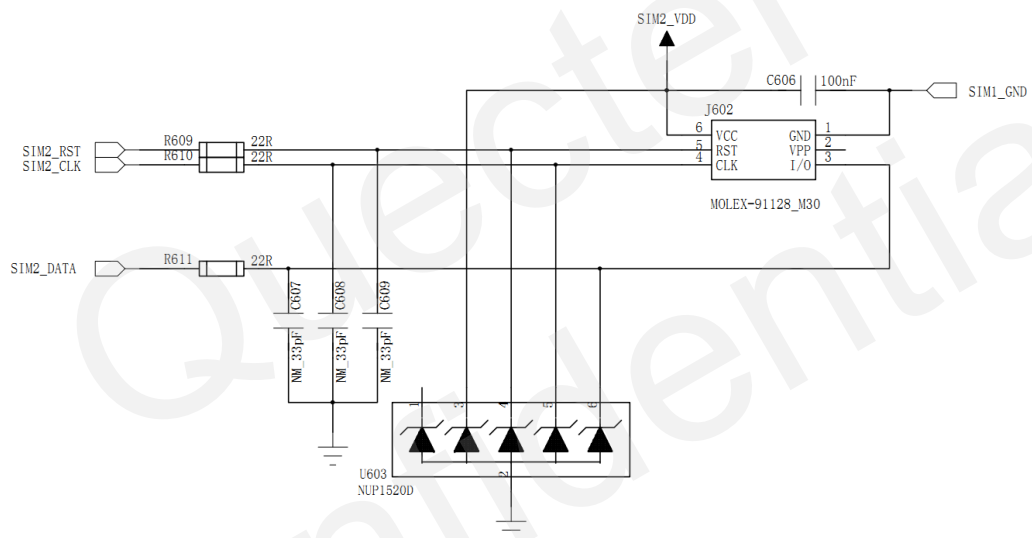

Figure 24: Circuit of SIM2 card

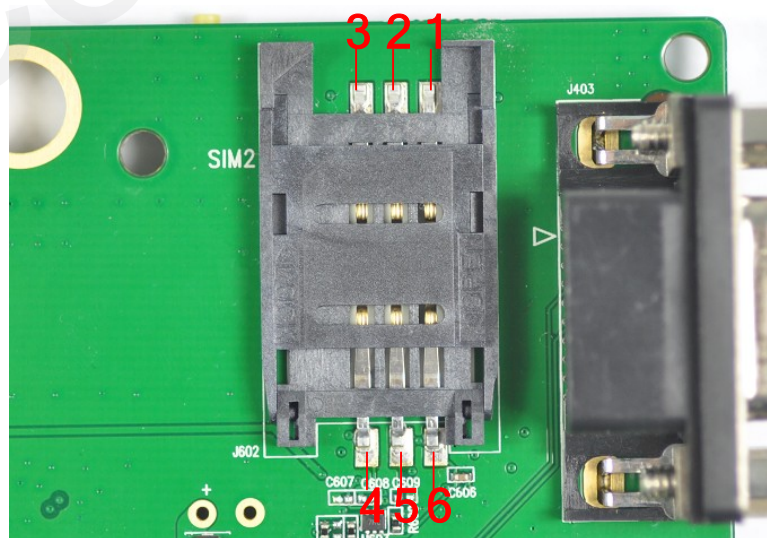

Figure 25: SIM2 card holder

**Table 13: Pin description of SIM2 card holder**

Pin NO.	Signal	I/O	Description	Note
1	GND		Ground	Not supported at present
2	VPP		Not connected	
3	SIM2_DATA	I/O	SIM2 card data I/O	
4	SIM2_CLK	O	SIM2 card clock	
5	SIM2_RST	O	SIM2 card reset	
6	SIM2_VDD	O	SIM2 card power	

### 3.5. Antenna interface

The U10 module has been equipped with a SMT RF connector (supplier part number: UF.L-R-SMT). Customers can complete the antenna installation easily. The Antenna installing is shown in Figure 26.

**Figure 26: Antenna installing**

### 3.6. UART port

U10 module has 3 UART ports: Main UART Port, Debug UART Port and Auxiliary UART Port. To communicate with PC, U10-EVB uses the SP3238CA to convert the UART CMOS level to RS-232 level. The following figure shows the UART block diagram.

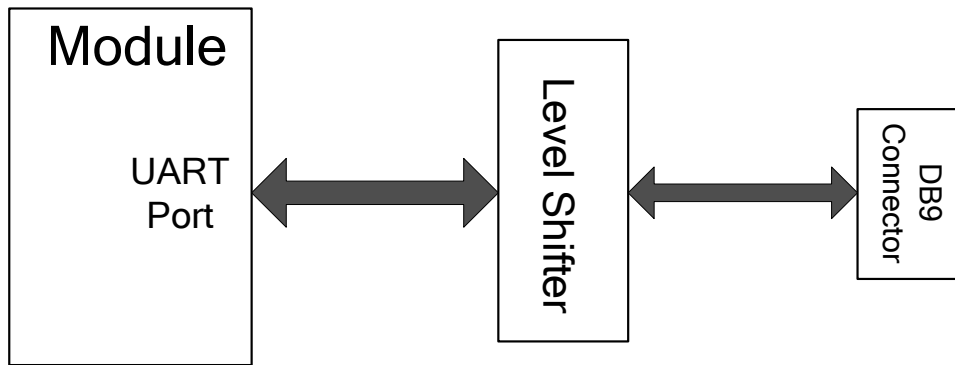

Figure 27: UART block diagram

The following figure shows the reference design of RS-232 level shifter.

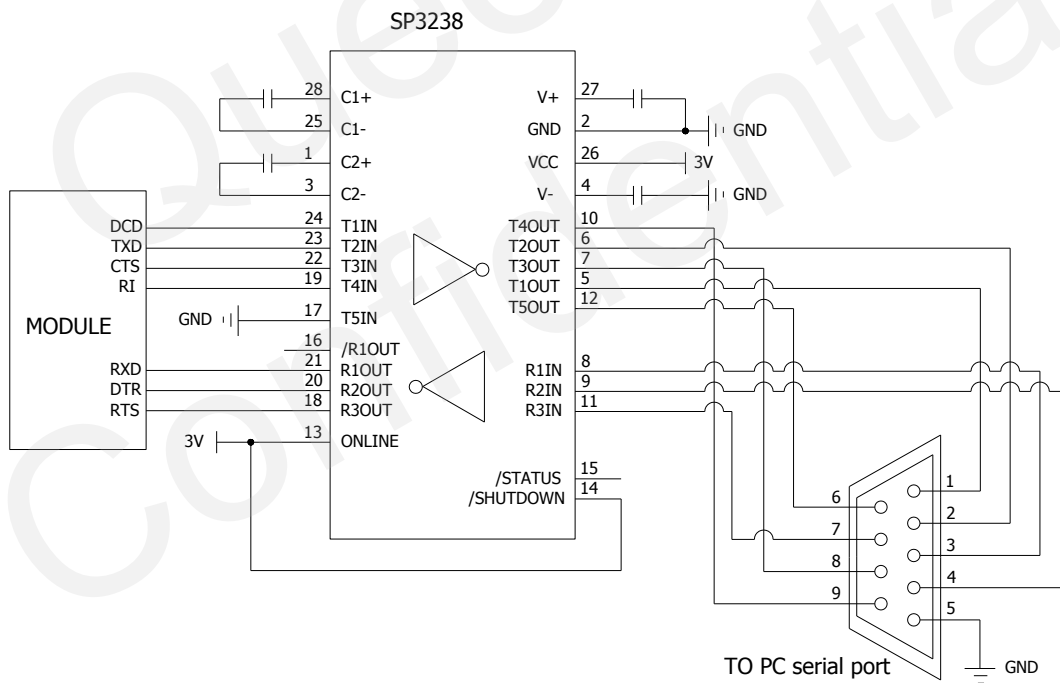

Figure 28: Level match circuit

### 3.6.1. Main UART

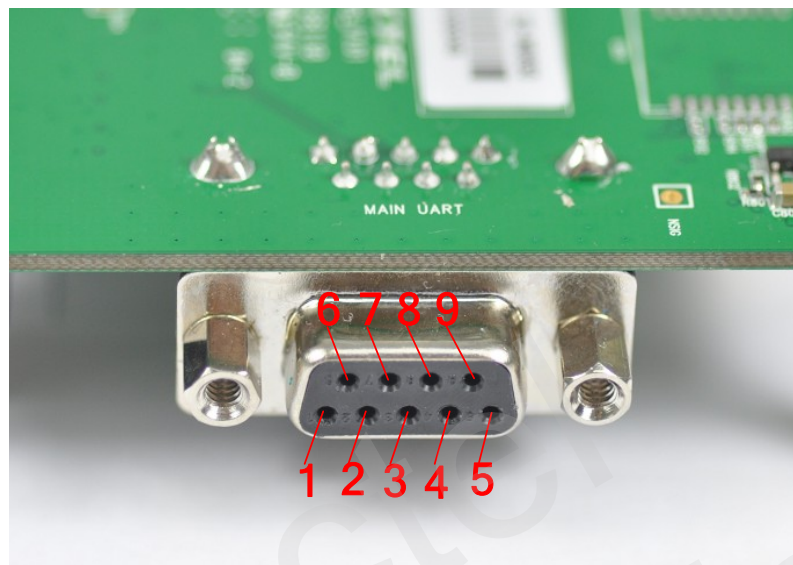

Figure 29: Main UART Port

Table 14: Pins of main UART port

Pin NO.	Signal	I/O	Description	Note
1	DCD	O	Data carrier detection	
2	TXD	O	Transmit data	
3	RXD	I	Receive data	
4	DTR	I	Data terminal ready	
5	GND	/	Ground	
6	NC	/	NC	
7	RTS	I	Request to send	
8	CTS	O	Clear to send	
9	RI	O	Ring indicator	

The voltage tested in the DB9 connector is RS232 level. The CMOS level of UART signal could be test via the following test points. Customer can use these test points to verify the design between the device and module.

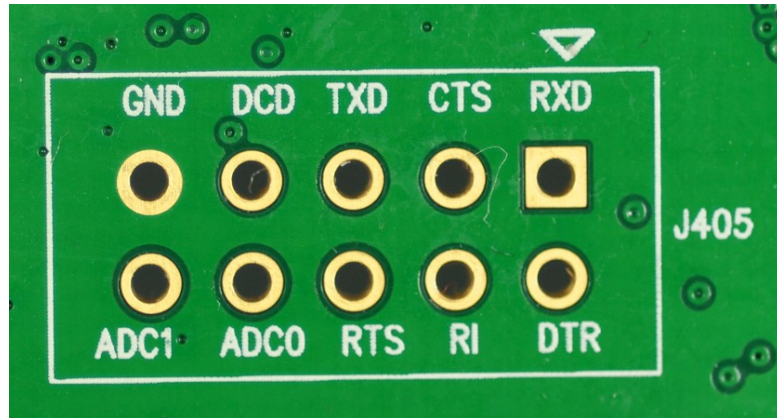

Figure 30: Test points of Main UART Port

The Main UART Port can be used for upgrading software. The PWRKEY pin must be pulled down before the software upgrade. For more details about downloading software with UART, please refer to *chapter 5.6.1*

### 3.6.2. Debug UART and Auxiliary UART

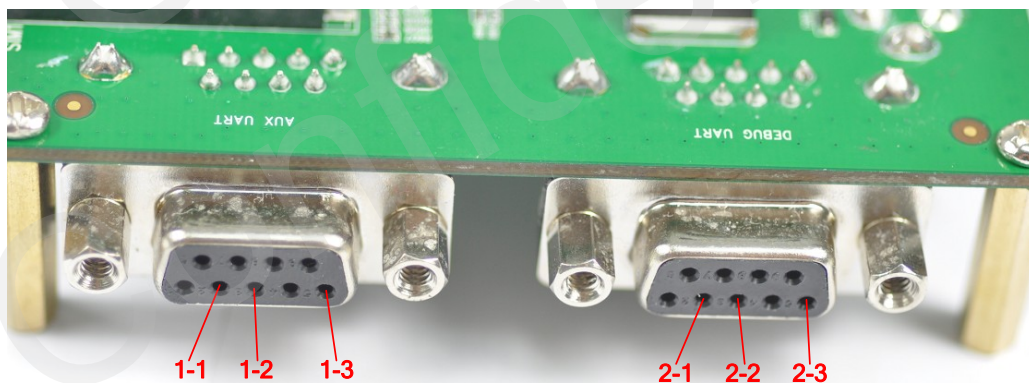

Figure 31: Auxiliary UART and Debug UART

Table 15: Pins of Auxiliary UART Port

Pin NO.	Signal	I/O	Description	Note
1_1	AUX_TXD	O	Send data to the RXD of DTE	
1_2	AUX_RXD	I	Receive data from the TXD of DTE	
1_3	GND	/	Ground	

**Table 16: Pins of Debug UART Port**

Pin NO.	Signal	I/O	Description	Note
2_1	DBG_TXD	O	Transmit data of the debug port	
2_2	DBG_RXD	I	Receive data of the debug port	
2_3	GND	/	Ground	

The voltage tested in the DB9 connector is RS232 level, the CMOS level of UART signal could be test through the following test points. Customer can use these test points to verify the design between the device and module.

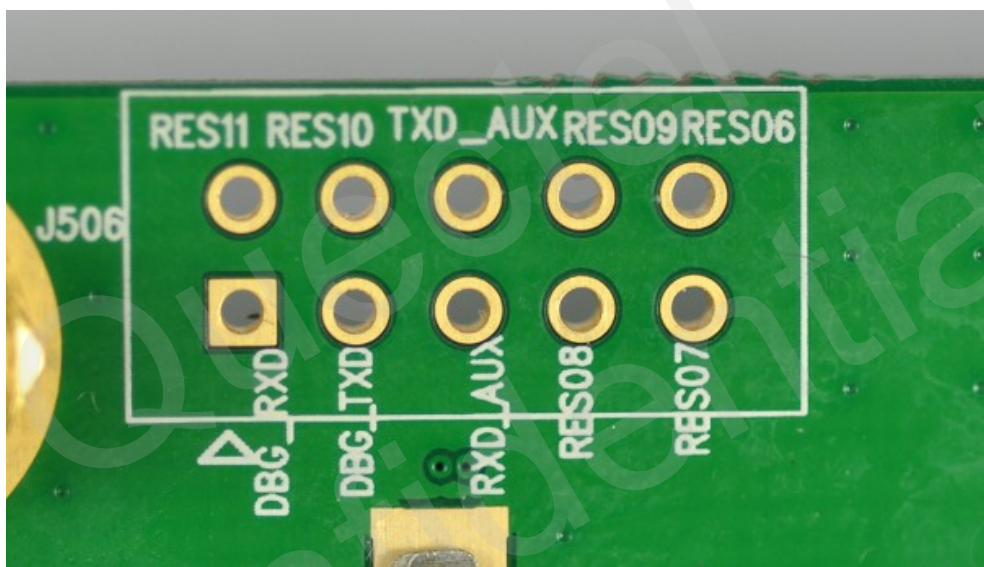
**Figure 32: Test points of Auxiliary and Debug Port**

### 3.7. Camera interface

The U10 can support camera and video functions. The U10-EVB provides two types of camera interface: analog camera and digital camera.

#### 3.7.1. Analog camera

U10-EVB provides two channels of analog camera. It employs an AK8856 IC which converts the analog video to digital video. The EVB also provides a boost converter for analog camera application. The following picture is the block diagram. For more information about the detailed design circuit, please refer to EVB circuit involving this part. The test point of analog camera is shown as below.

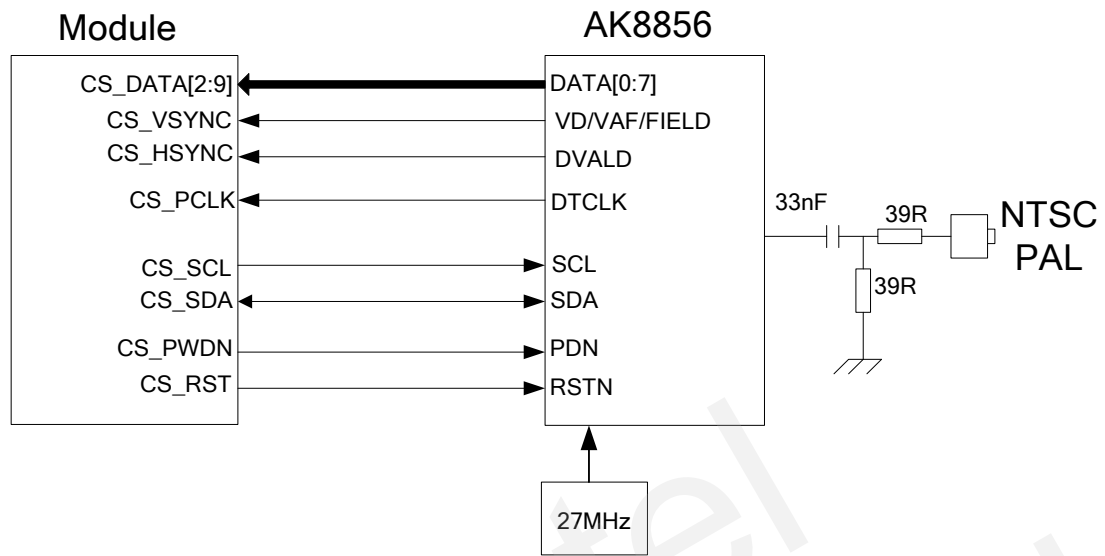

Figure 33: Block diagram of Analog camera

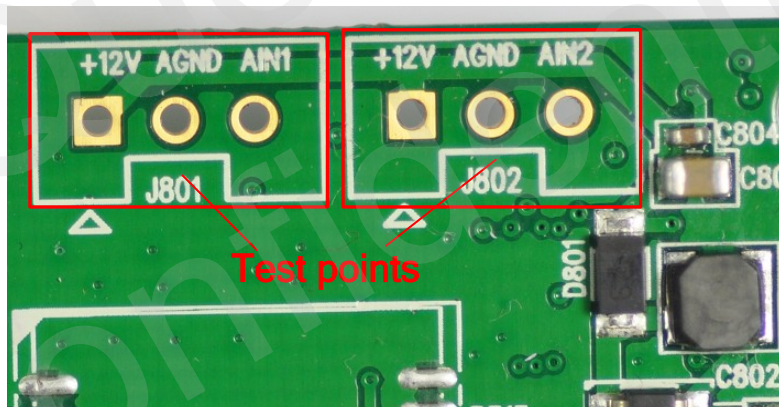

Figure 34: Test points of Analog camera

The following picture is the sample of analog camera. Customer can connect the analog camera to EVB through contact pins. For more details about the analog camera, please contact the vendor of the analog camera or Quectel.



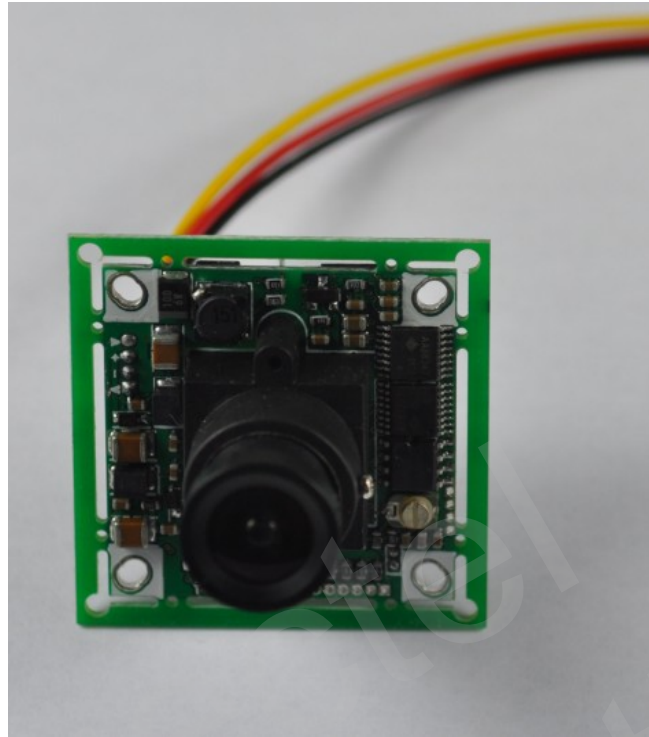

Figure 35: Analog camera

### 3.7.2. Digital camera

U10-EVB provides a parallel digital camera interface. The following figure shows the reference design of the interface.

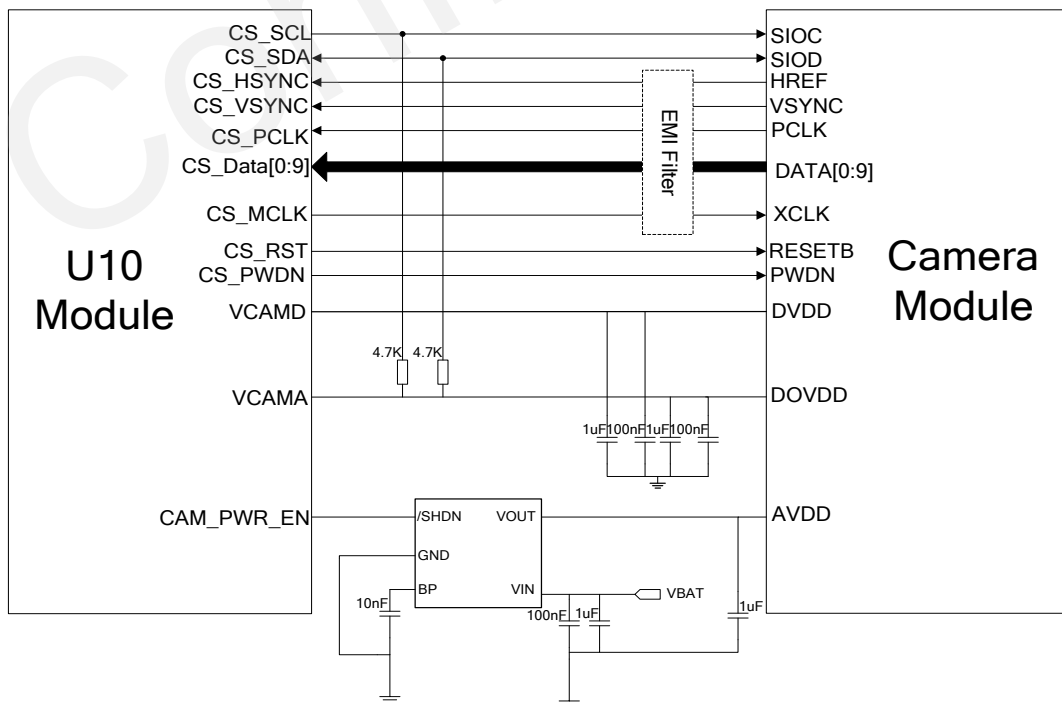

Figure 36: Reference circuit of using digital CMOS sensor

The following figure shows the placement of the connector and the installation of the camera module.



Figure 37: Installation of the camera module.

Table 17: Pin definition of the camera interface

Pin NO.	Pin Name	Function
1	Strobe	NC
2	AGND	Ground for analog circuit
3	SIOD	I2C data
4	AVDD	Power for analog circuit/sensor array
5	SIOC	I2C clock
6	RESET	Reset the sensor, active low
7	VSYNC	Vertical sync output
8	PWDN	Power down, active high
9	HREF	Horizontal reference output
10	DVDD	Power for digital core
11	DOVDD	Power for I/O circuit
12	DATA9	Data bit 9 of camera sensor
13	XCLK	System input clock
14	DATA8	Data bit 8 of camera sensor
15	DGND	Ground for I/O circuit
16	DATA7	Data bit 7 of camera sensor
17	PCLK	Pixel clock output
18	DATA6	Data bit 6 of camera sensor
19	DATA2	Data bit 2 of camera sensor
20	DATA5	Data bit 5 of camera sensor
21	DATA3	Data bit 3 of camera sensor
22	DATA4	Data bit 4 of camera sensor



**Table 18: Pin definition of the SD card interface**

Pin NO.	Pin Name	I/O	Description	Note
1	DATA2	I/O	Data output and input signal of SD card	
2	DATA3	I/O	Data output and input signal of SD card	
3	CMD	O	Command signal of SD card output	
4	VDD	/	Power supply for SD card	
5	CLK	O	Clock signal of SD card output	
6	GND	/	Ground	
7	DATA0	I/O	Data output and input signal of SD card	
8	DATA1	I/O	Data output and input signal of SD card	

*Note: The Micro SD card can be accessed through AT command. More details please refer to document [1].*

### 3.9. USB interface

The U10 module provides a USB interface which complies with USB 2.0 standard for high-speed (480Mbps) functions. The Mini-A receptacle is recommended as U10-EVB's interface for connecting USB cable.

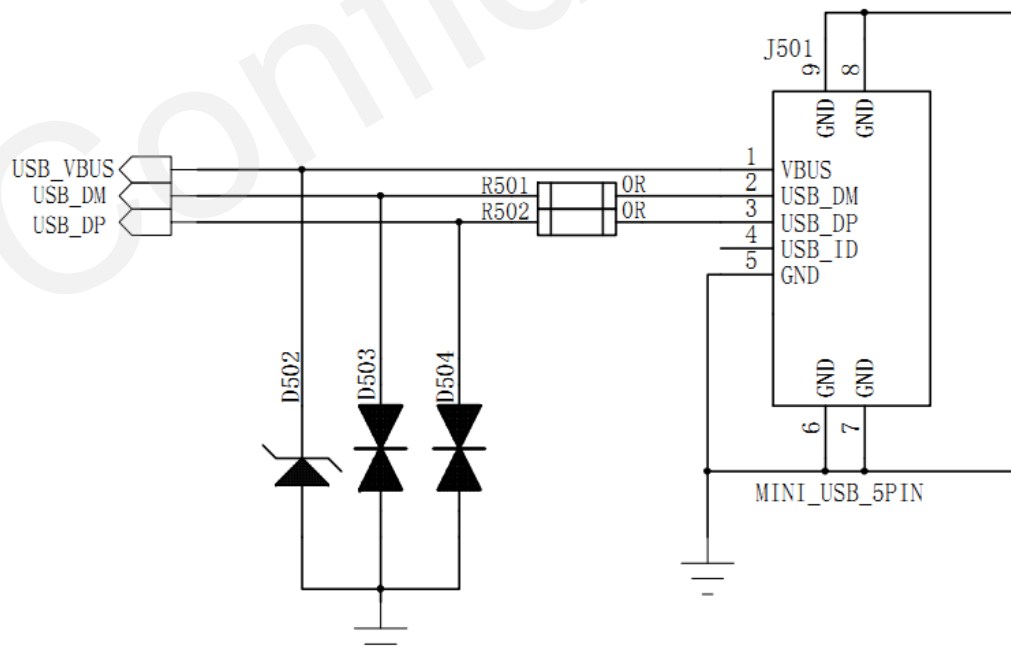
**Figure 40: Circuit of USB interface**

The EVB uses an A-type female mini USB connector for applications as shown in the following figure.

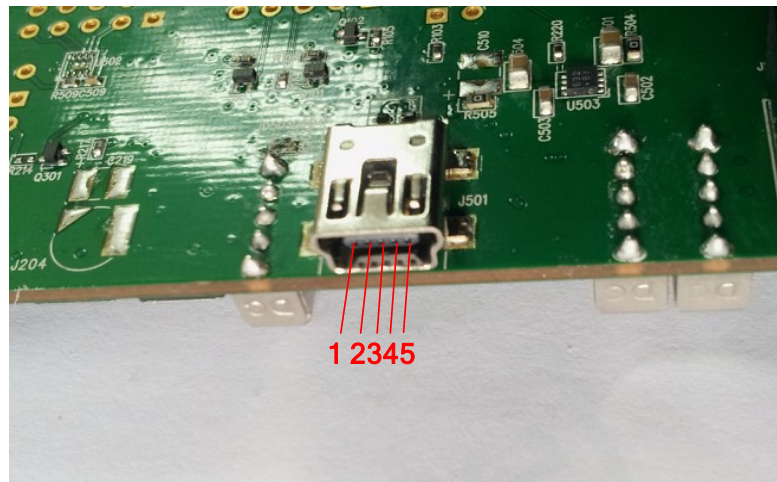

**Figure 41: Mini USB connector**

The pin definition is listed in the following table.

**Table 19: Pin definition of USB interface.**

Pin NO.	Pin Name	Function
1	USB_VBUS	This pin is used for USB detection.
2	USB_DM	USB serial differential bus (minus).
3	USB_DP	USB serial differential bus (positive).
4	USB_ID	NC
5	GND	GND for USB interface.

It is recommended to use mini USB cable for connecting the EVB to PC or other application platform. The cable is shown as below:

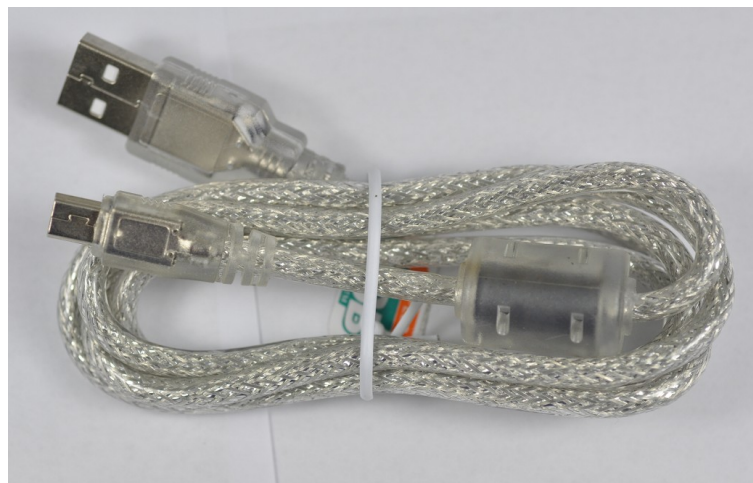

**Figure 42: USB cable**

### 3.10. Switches and buttons

The following figure shows the button and switch placement.

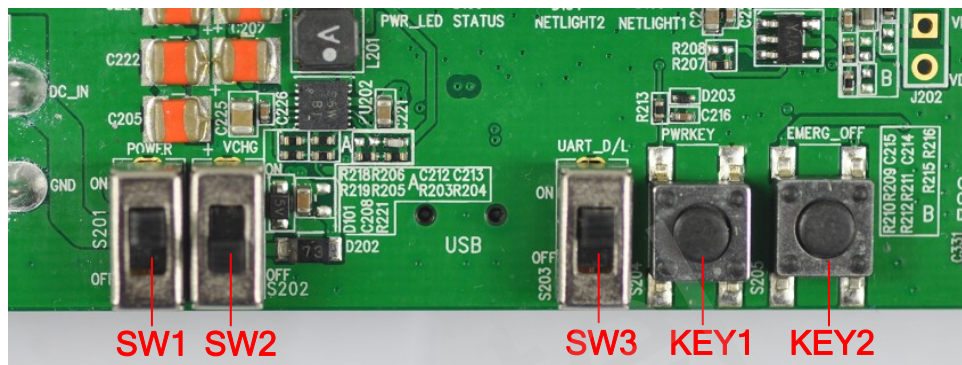

Figure 43: Switches and buttons

Table 20: Switches and buttons

Part	Name	I/O	Description	Note
SW1	POWER	I	Control power supply ON/OFF	
SW2	VCHG	I	Control charging if module has charging function	
SW3	UART_D/L	I	Pull to “ON” when downloading firmware via UART	
KEY1	PWRKEY	I	Press the button for about 2s to Power on/off the module	
KEY1	EMERG_OFF	I	Emergency button for shutting down the system	

#### 3.10.1. Switch for VBAT power supply

SW1 is used to switch ON or OFF the power supply for VBAT of the module. Customers must select this switch to ON to get VBAT power supply.

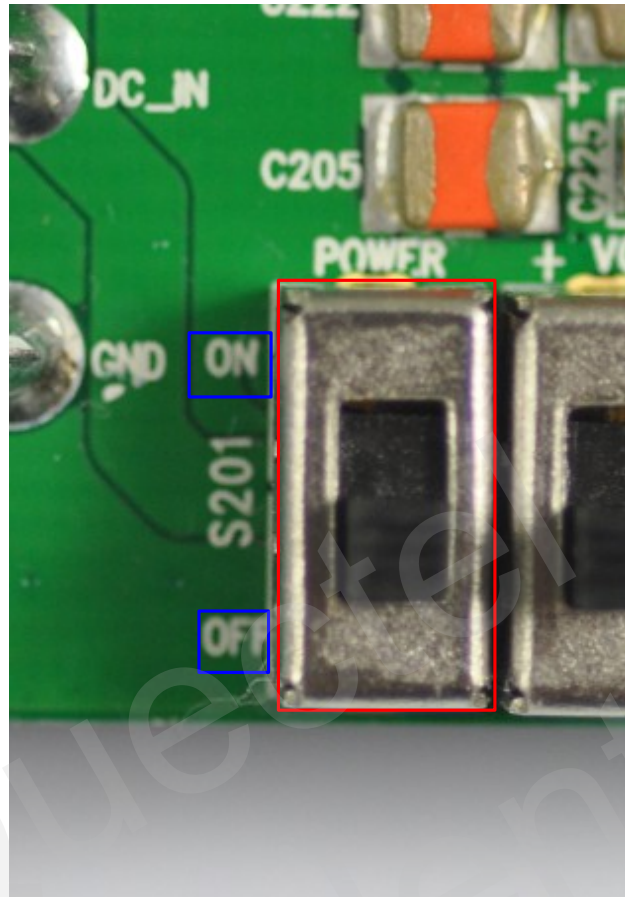

Figure 44: Switch for VBAT power supply

### 3.10.2. Switch for VCHG function

SW2 is used to switch ON or OFF for opening or closing the module charging function. Customers must switch SW2 to ON to open the charging when a battery exists on J103.

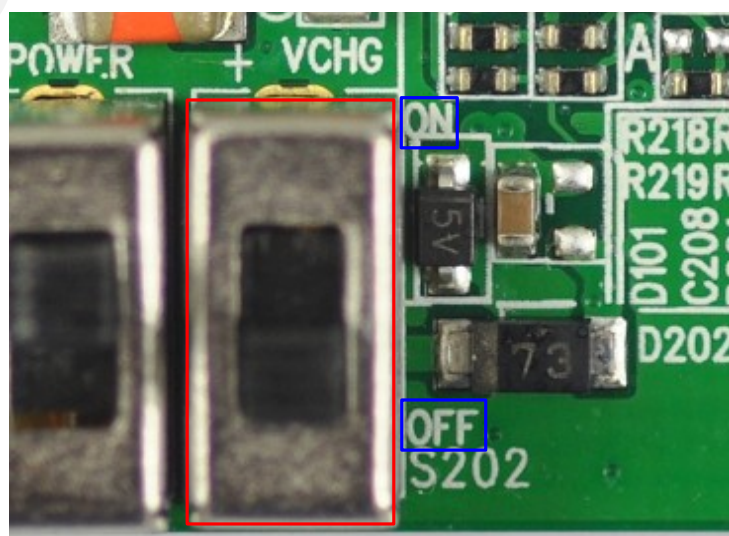

Figure 45: Switch for charging function

### 3.10.3. Switch for UART download

Switching SW3 to ON can make the U10 entered into UART download mode when the Firmware update tool is processing.

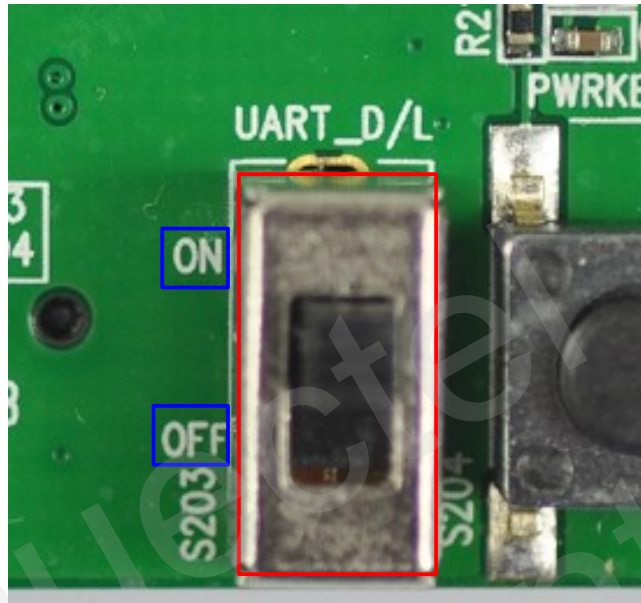

Figure 46: Switch for UART download

### 3.10.4. Button for PWRKEY

Customers can press the button KEY1 for about 2 seconds to power on the module when the VBAT voltage is existed. The button also can be used for powering off the module when the module is in power-on mode. For more details about powering on and off, please refer to *document [3]*.

### 3.10.5. Button for EMERG\_OFF

Customers can press the button KEY2 for at least 20 ms to power off the module only when the module is under emergent situation such as the module is unresponsive or abnormal. Although turning off the module by EMERG\_OFF is fully tested and nothing wrong detected, this operation is still a big risk as it could cause destroying of the code or data area of the NAND flash memory in the module. Therefore, it is recommended that PWRKEY or AT command should always be the preferential way to turn off the system. For more details about powering on and off, please refer to *document [3]*.



### 3.11. Operating Status LED

The following figure shows the status information of the U10 module.

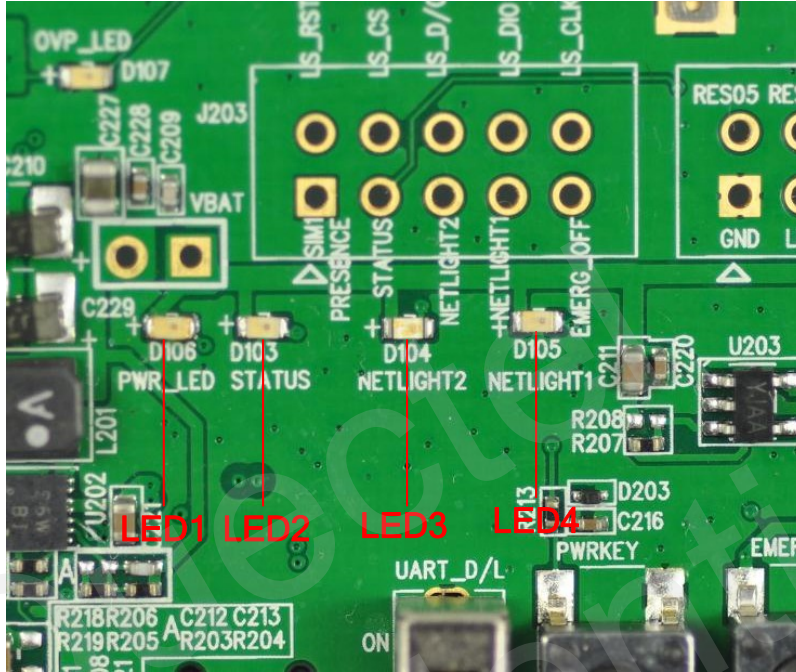

Figure 47: Operating status LED

Table 21: Status LEDs

Part	Name	I/O	Description	Note
LED1	VBAT ON/OFF indicator	O	Bright: VBAT ON Extinct: VBAT OFF	
LED2	Module status indicator	O	Indicate module’s operating status Bright: module powers on Extinct: module powers down	
LED3	NETLIGHT2 status indicator	O	Blinking at a certain frequency according to various network status	Not supported
LED4	NETLIGHT1 status indicator	O	Blinking at a certain frequency according to various network status	

For more details, please refer to *document [3]*.

### 3.12. ADC

U10 provides two analog-to-digital converter (ADC) channels that can digitize the analog signal to 12-bit digital data such as battery voltage, temperature and so on. The test point and circuit are shown as below.

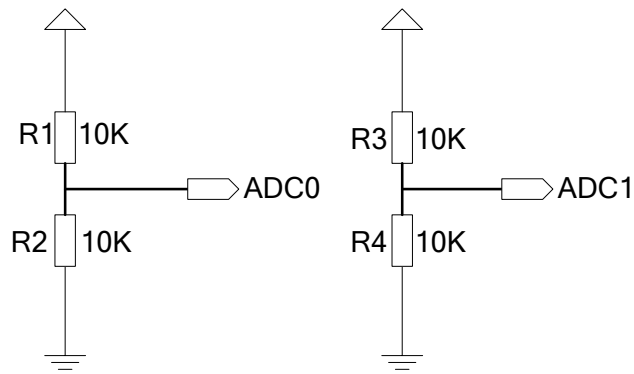

Figure 48: Circuit of ADC

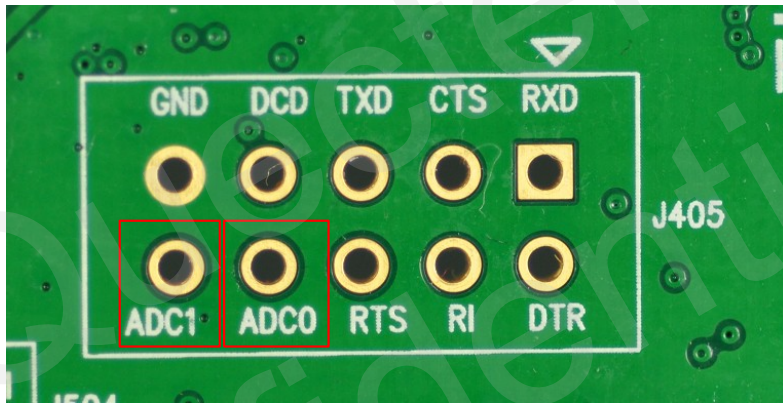

Figure 49: Test point of ADC

### 3.13. Test points

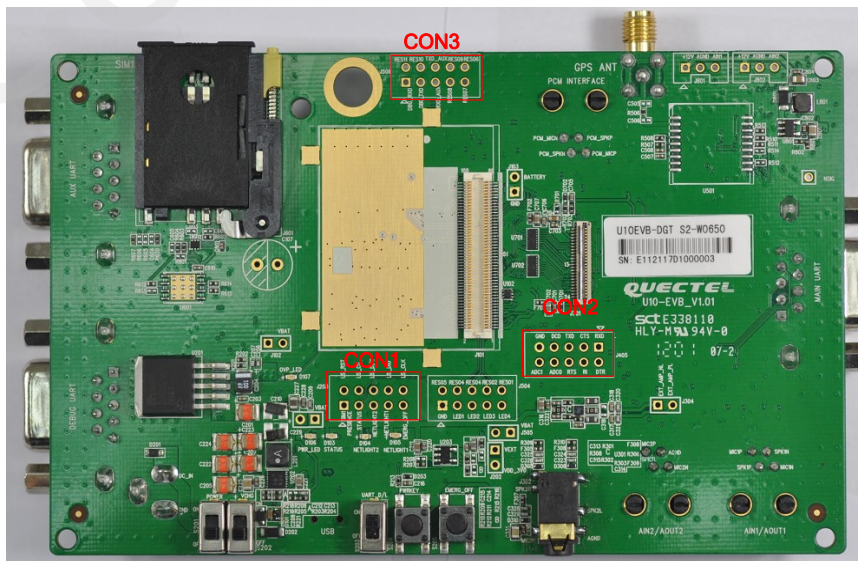

Figure 50: Test points overview

### 3.13.1. CON1

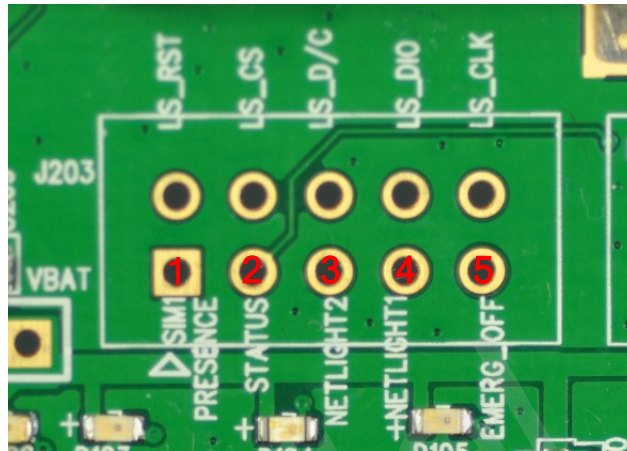

Figure 51: CON1

Table 22: Pins of CON1

Pin NO.	Signal	I/O	Description	Note
1	SIM_PRESENCE	I	SIM Card detect	
2	STATUS	O	Indicate module's operating status	
3	NETLIGHT2	O	Network status indication	
4	NETLIGHT1	O	Network status indication	
5	EMERG_OFF	I	Emergency off. Pulled down for at least 20ms, module will be turned off in case of emergency.	

### 3.13.2. CON2

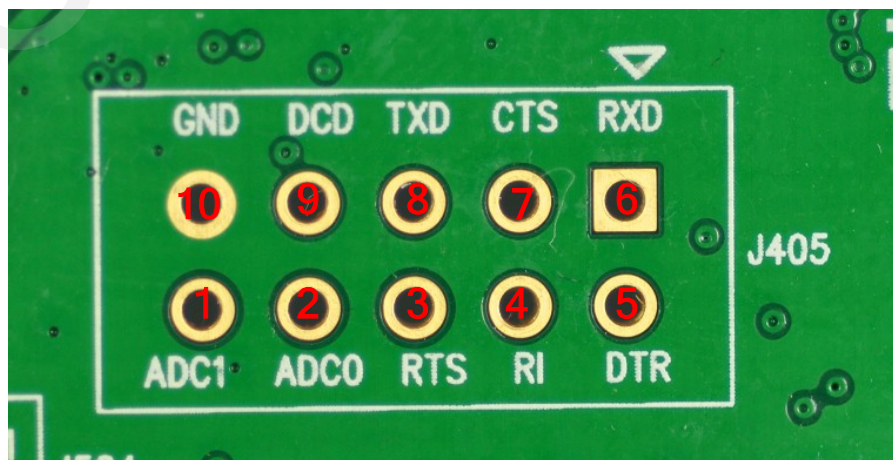

Figure 52: CON2

Table 23: Pins of CON2

Pin NO.	Signal	I/O	Description	Note
1	ADC1	I	General purpose analog to digital converter.	
2	ADC0	I	General purpose analog to digital converter.	
3	RTS	I	Request to send	
4	RI	O	Ring indicator	
5	DTR	I	Data terminal ready	
6	RXD	I	Receive data	
7	CTS	O	Clear to send	
8	TXD	O	Transmit data	
9	DCD	O	Data carrier detection	
10	GND	/	Power GND	

### 3.13.3. CON3

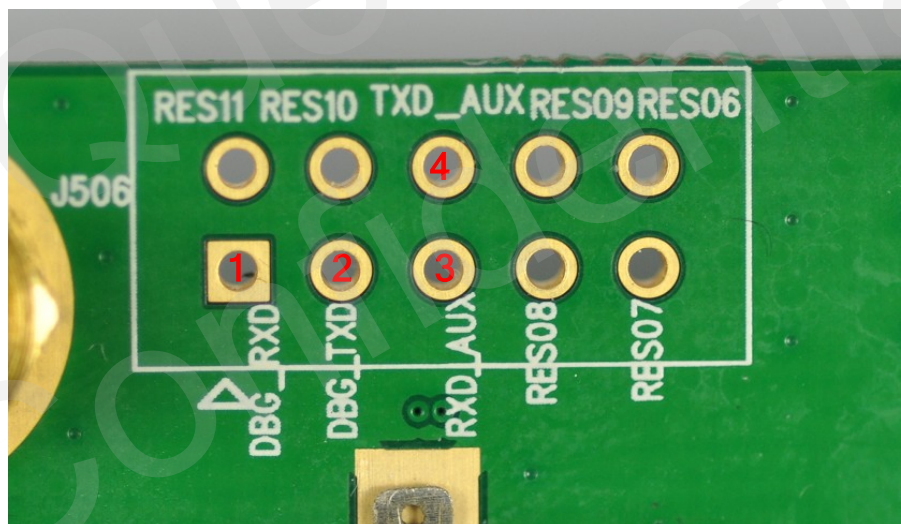

Figure 53: CON3

Table 24: Pins of CON3

Pin NO.	Signal	I/O	Description	Note
1	DBG_RXD	I	RX Pin for Debug port	
2	DBG_TXD	O	TX Pin for Debug port	
3	AUX_RXD	I	RX Pin for Auxiliary port	
4	AUX_TXD	O	TX Pin for Auxiliary port	

## 4. EVB accessories assembly

Generally, the EVB and its accessories are equipped as Figure 54.



Figure 54: EVB and accessories equipment

## 5. Illustration

### 5.1. Power on

1. Connect the U10 module to the 100 pins connector on U10-EVB, plug in the 5V power adapter.
2. Switch SW1 to **ON** state, Switch SW2 to **OFF** state, Switch SW3 to **OFF** state. The LED1 on the EVB will be bright.
3. Press the KEY1 button (PWRKEY) for about 2 seconds. The LED2 will be light and indicates power-on mode. When LED2 is bright, the module begins running. Otherwise, please check the connection.
4. The LED4 will be blinking at a certain frequency. The network status of the module can be judged by this LED. The working state of the Net Light is shown as below:

**Table 25: Working state of the NETLIGHT1**

State	Module function
Off	The module is not running.
35ms On/ 500ms Off	The module is not synchronized with network.
70ms On/ 1000ms Off	The module is synchronized with network.
23ms On/ 333ms Off	Data transfer is ongoing with GSM network.
11ms On/ 162ms Off	Data transfer is ongoing with 3G network.

Please refer to *document [3]* for detailed network status indication.

### 5.2. Power off the module

Press the PWRKEY button for about 2 seconds, the module will be turned off. For more information about the timing of powering off, please refer to *document [3]*.

### 5.3. Emergency off

Press the EMERG\_OFF button for more than 0.2 seconds, the module will be shut down immediately. After that, the module can be restarted by pressing the PWRKEY button. Please note that this operation is harmful to the whole module system and should only be done in emergency such as failing to turn off the module through the PWRKEY button.

## 5.4. Communicate with the module through UART port

1. Connect the UART port to PC with USB to UART converter cable.
2. Open the HyperTerminal (AT command window) on PC. The location of the HyperTerminal in windows XP is: START →program →accessory →communication →HyperTerminal. Set appropriate Baud Rate (such as 115200 bps) and COM number which can be checked by the Device Manager on PC.
3. Connect an antenna to U10 with an RF cable.
4. Insert SIM card into the SIM card socket.
5. Insert earphone or handset into audio interface.
6. Power on the module. Please refer to *chapter 5.1*.
7. After waiting for 2~3 seconds, customer should first input “AT” or “at” string once or more until receiving “OK” from the module in the HyperTerminal. The module is set to autobauding mode in default configuration. This operation is to synchronize the baud rate between the computer and the module.
8. Input AT command and the module will execute its corresponding function.

Please refer to *document [1]* for the details of AT commands. For instance, when inputting “ATD112;” an emergency call is established.

*Note: Please install the USB-to-RSR232 Driver from the Driver Disk before using the UART Port to communicate with PC.*

## 5.5. Communicate with the module through USB interface

1. Power on the module.
2. Connect EVB and PC with USB cable through their USB interface.
3. Open the HyperTerminal (AT command window) on PC. Set appropriate Baud Rate (such as 115200 bps)
4. Input “AT” or “at” string once or more until receiving “OK” from the module in the HyperTerminal.
5. Input AT command and the module will execute its corresponding function.

Please refer to *document [1]* for the details of AT commands.

*Note: If you want to use the USB interface with PC, the driver program should be installed first.*

## 5.6 Firmware upgrade

Sometimes customers need to upgrade the firmware. U10-EVB has two ways to update the firmware. One is through the Main UART Port, the other one is through the USB interface.

### 5.6.1. Upgrade firmware through UART interface

When customer wants to upgrade the firmware through the Main UART Port, the following process should be complied with:

1. Connect the serial port on U10-EVB to PC with USB to UART converter cable.
2. Start the Firmware Upgrade Tool in the PC.
3. Press the **START** button in the Firmware Upgrade Tool.
4. Plug in the 5V power adapter. Switch the SW1 and SW3 in the EVB to **ON** state.

After these steps, the firmware refreshing process will be proceeding. For more details, please refer to *document [3]*.

### 5.6.2. Upgrade firmware through USB interface

The following process should be complied with when using the USB interface to upgrade the firmware:

1. Open the Firmware Upgrade Tool in the PC and press the **START** button.
2. Plug in the 5V power adapter. Switch the SW1 to **ON**, Switch SW2 and SW3 to **OFF**.
3. Connect U10-EVB to PC with the USB cable, the module will auto power on and enter into USB download mode when the USB cable is inserted.

After these steps, the firmware refreshing process will be proceeding.

*Note: When customer designs the USB download circuit, please connect **USB\_DL** pin to the **USB\_VBUS** through a Switch, which can make the module entered into the USB download mode. For more details, please refer to document [3].*



# QUECTEL



**Shanghai Quectel Wireless Solutions Co., Ltd.**

**Room 501, Building 13, No.99 Tianzhou Road, Shanghai, China 200233**

**Tel: +86 21 5108 6236**

**Mail: [info@quectel.com](mailto:info@quectel.com)**