

REVISION RECORD				
REV	ECN	DESCRIPTION	DRFT	DATE

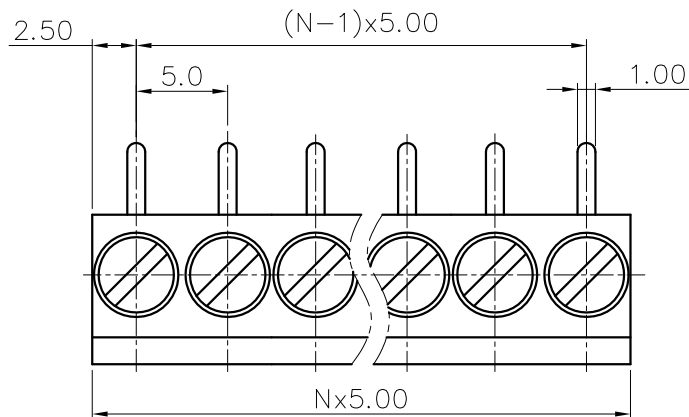

NOTES1:

UL Standard

1. Rated voltage/current : 300V / 15A
2. Torque Value : M2.5 , 3.54Lb.in
3. Wire Range : 22~12AWG

IEC Standard

1. Rated voltage/current : 250V / 22A
2. Torque Value : M2.5 , 0.4N.m
3. Wire Range : 0.5~2.5mm²

NOTES2:

1. Dimension shall be interpreted per ASME Y14.5-2009
2. Pitch : 5.0mm, Poles : N=02~12P
3. Stripping length : 5mm
4. Withstanding voltage : AC2000V/1Min
5. Operating temperature: -40°C~+105°C
6. Undimensioned tolerances:

Pitch range in mm	Nominal dimension range in mm						0.1/10
	Over 6 TO 10	Over 10 TO 24	Over 30 TO 30	Over 60 TO 60	Over 100 TO 150	Over 150	
±0.15	±0.20	±0.30	±0.30	±0.50	±0.70	±1.00	±2*

7. RoHS Compliance

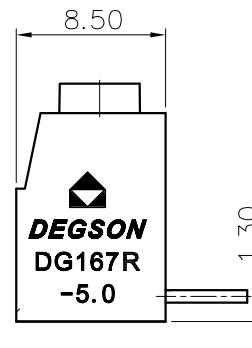
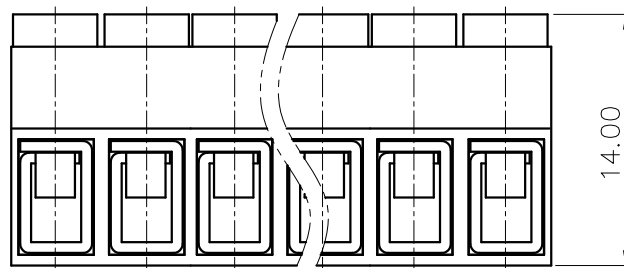
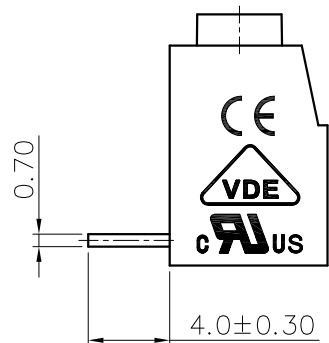

DG167R - 5.0 - XXP - 1Y - 00A (H)
 (Series No.) (Pitch) (Poles) (Single Pitch) (Color): 1.(Grey)
 2.(Blue)
 3.(Black)
 4.(Green)
 5.(Orange)
 6.(Red)
 7.(Transparent)
 8.(Yellow)
 9.(White)

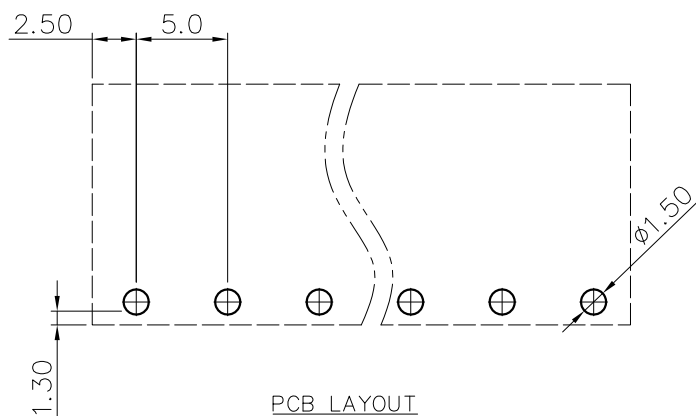

DETACHED LISTS	PART NO.:	宁波高松电子有限公司 NINGBO DEGSON ELECTRICAL CO., LTD			
	APPD:	NAME: DG167R-5.0-XXP-1Y-00A(H)			
	CHKD:	TITLE: CUSTOMER DRAWING			
	DRFT:	DRAWING NO.:		REV	DO
THIRD ANGLE PROJECTION		DO NOT SCALE DRAWING	SHEET	1/1	
		MM (INCH)	SCALE	1:1	